

# Y8 Pressure project

FORCE PER UNIT OF AREA

PRESSURE (Pa)



2

$$P = F / A$$

FORCE (N)

AREA (m<sup>2</sup>)

Learned	Revised	Confident
_____ % Achieved: _____		

Nº	Keyword	Definition
1	Pressure	Pressure is a measure of how spread out a force is.
2	Pressure equation	Pressure = Force / Area

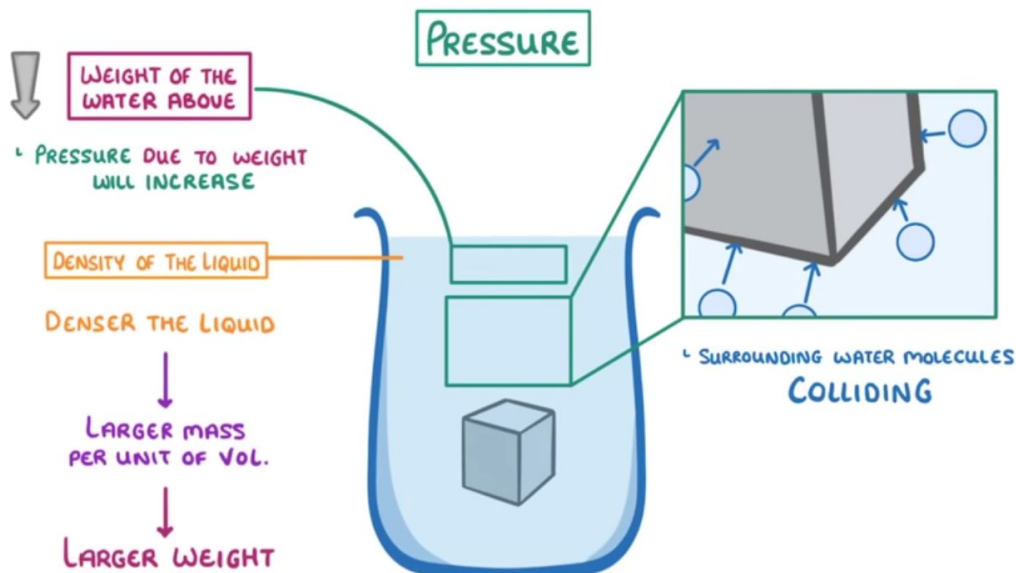

Nº	Facts
3	We can increase the pressure by increasing the force or by decreasing the area
4	Pressure is caused by particles colliding with the walls of a container e.g. a tyre
5	Pressure varies with depth under water and height above sea level
6	The deeper you go under water, the higher the pressure as there are more particles above you so a bigger force
7	The higher you go above sea level the lower the pressure in the atmosphere as the air is less dense so fewer particles so less force



# Y8 Electricity

POWER SOURCE

CIRCUITS

↳ CLOSED LOOP



COMPONENTS

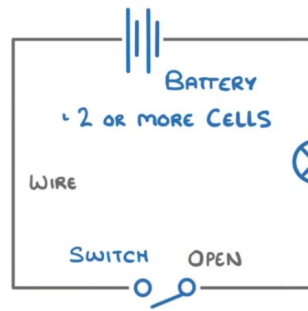

POTENTIAL DIFFERENCE

CURRENT

RESISTANCE

Learned	Revised	Confident
_____ % Achieved: _____		

Nº	Keyword	Definition
1	Circuit	An electrical circuit is made of components that are connected using wires
2	Component	A part of a circuit e.g. a battery or lamp. They are represented using symbols
3	Circuit symbol	The scientific way to represent different components in a circuit
4	Current	Current is the flow of charge (electrons) around a circuit. It is measured in amps (A)
5	Potential difference	Potential difference is the energy transferred by each unit of charge. It is measured in volts (V)
6	Series circuit	All of the components in a circuit are in one "loop" with only one route for current to flow
7	Parallel circuit	A circuit that has multiple "loops" or "branches", the current can flow around different routes
8	Resistance	How difficult it is for the current to flow

9

Nº	Facts
10	A circuit has to be complete to work, this is so that the current can flow.
11	If we add components to a circuit we increase the resistance and this decreases the current
12	The potential difference in a series circuit is shared between all of the components; it totals the same as the power supply (cell or battery)

# Y8 Diffusion project

Learned    Revised    Confident

\_\_\_\_\_ % Achieved: \_\_\_\_\_

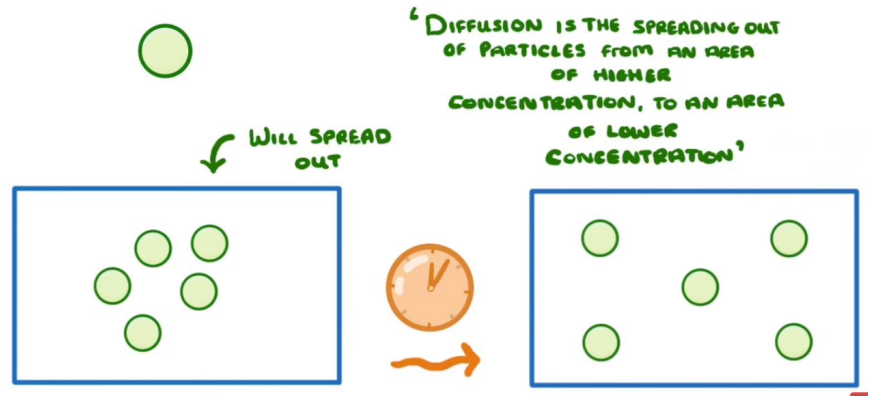

Nº	Keyword	Definition
1	Concentration	The number of particles of one substance in a specific volume of another substance.
2	Particle	A single piece of a substance. This could be an atom, molecule or ion.
3	Diffusion	Net movement of particles from an area of high concentration to an area of lower concentration

## 4 CONCENTRATION GRADIENT

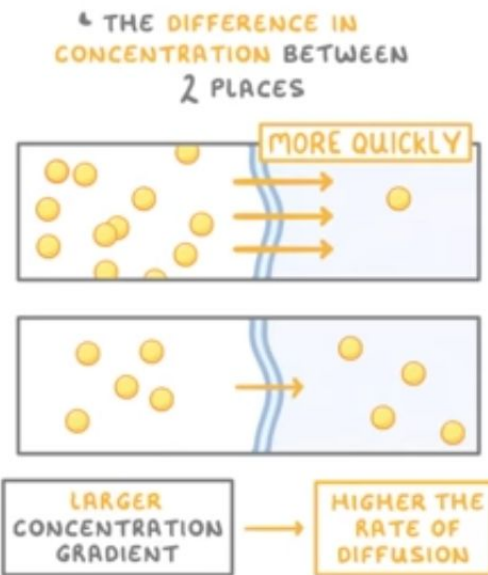

## 5 TEMPERATURE

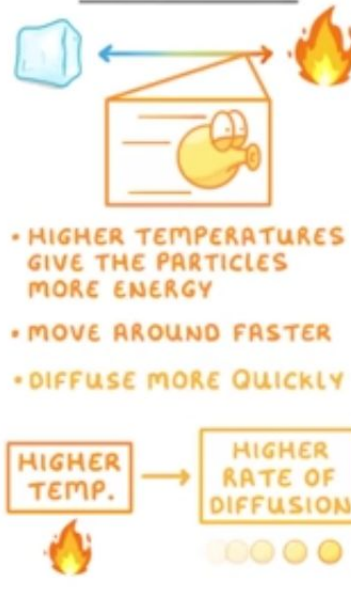

## 6 SURFACE AREA

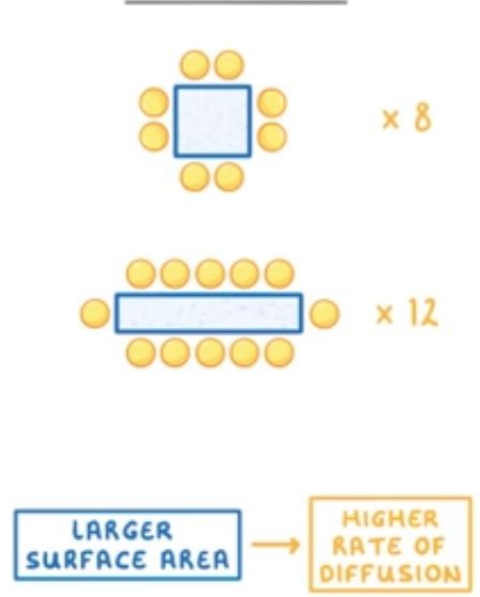

Nº	Fact
9	Diffusion is how smells spread through the air or how coffee spreads through hot water
10	Diffusion takes place in our organs. It is how oxygen moves from our lungs into our blood.
11	We can increase the surface area of a solid by cutting it into smaller pieces. This creates more surfaces for diffusion to take place through

# Y8 Photosynthesis

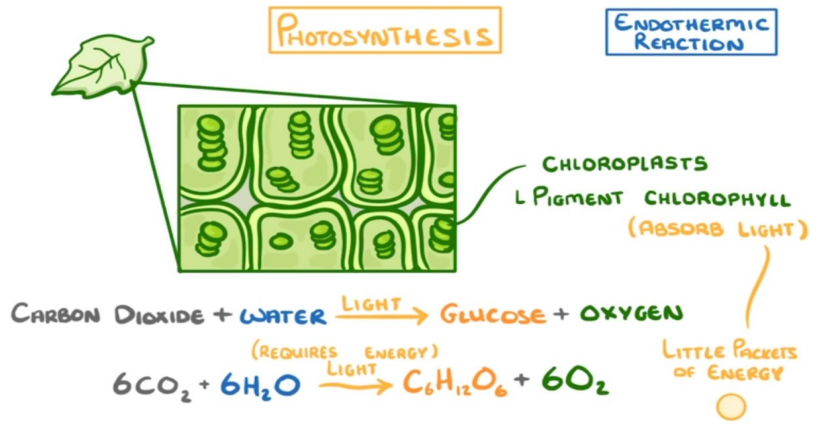

Learned	Revised	Confident
_____ % Achieved: _____		

N°	Keyword	Definition
1	Photosynthesis	A chemical reaction that occurs in the chloroplasts of plants in which the energy in light is stored in glucose
2	Product(s)	Chemical(s) present at the end of a reaction. Products appear on the right of an equation, after the arrow
3	Reactant(s)	Chemical(s) present at the start of a reaction. Reactants appear on the left of an equation, before the arrow
4	Chloroplasts	The sub cellular structure that contains chlorophyll where photosynthesis takes place
5	Stomata	Small pores found on the underside of leaves, they control gas exchange and prevent water loss
6	Root hair cell	A cell found in the roots of plants, it is specialised to take in water and minerals with a large surface area



N°	Fact
8	The photosynthesis word equations is : Carbon dioxide + Water → Glucose + Oxygen
9	Photosynthesis requires light to take place. The light provides energy for the reaction meaning that photosynthesis is endothermic
10	Some factors that can affect photosynthesis are: light intensity, light colour, temperature, carbon dioxide levels and amount of chlorophyll.
11	Plants use the glucose they make for different purposes. These include: used in respiration; producing cellulose for cell walls; stored in starch, fats and oils and used to help make amino acids (for proteins).