

# Biology

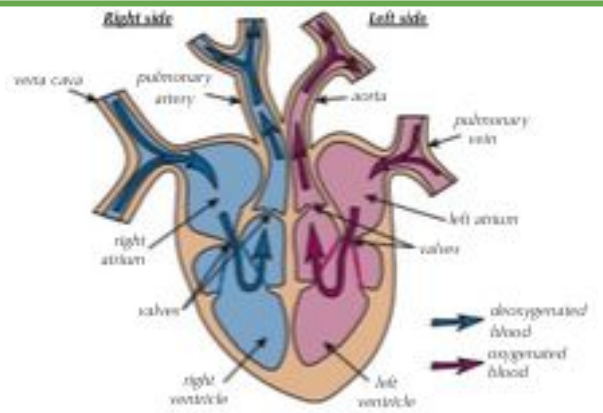

Learned	Revised	Confident
_____ % Achieved: _____		

N°	Keyword	Definition
2	Alveoli	Tiny air sacs arranged in clusters throughout the lungs. They provide a large surface area for gas exchange.
3	Benign tumour	A growth of abnormal cells contained in one area, usually within a membrane.
4	Carbohydrase	An enzyme that breaks down carbohydrates into simple sugars. Eg: Amylase
5	Digestion	When large insoluble molecules are broken down into small soluble molecules
6	Enzyme	A biological catalyst that speeds up the rate of a reaction.
7	Lipase	An enzyme that breaks down lipids into fatty acids and glycerol
8	Malignant	A growth of cells that can invade neighbouring tissues and spread to different parts of the body in the blood where they form secondary tumours.
9	Protease	An enzyme that breaks down proteins into amino acids

10 Blood vessels

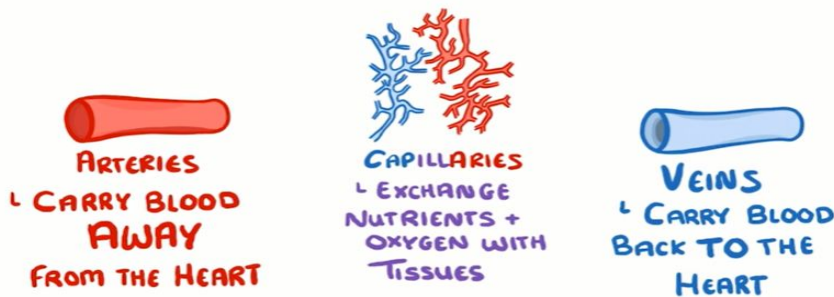

Treatment	Description	Advantage	Disadvantage
Statins	A type of drug that reduces blood cholesterol levels to slow down the rate at which fatty material is deposited in the coronary arteries.	Can reduce the risk of strokes, CHD and heart attacks.	Long term treatment and negative side effects.
Stents	A metal mesh tube placed in an artery to hold it open.	The success rate is high, they lower the risk of a heart attack and last for a long time.	Drugs needed to stop blood clotting.

# GCSE Plant Organisation

Learned	Revised	Confident
_____ % Achieved: _____		

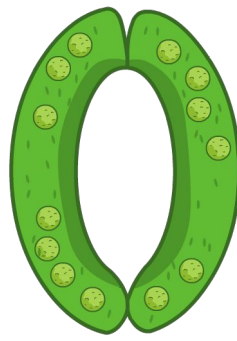

1

## Guard cells

When there is plenty of water, the guard cells swell and become turgid, opening the stomata. When short of water, the guard cell loses water, becomes flaccid and the stomata close. They are also sensitive to light.

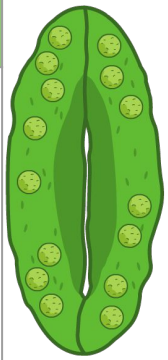

N°	Keyword	Definition
2	Guard cell	A cell which controls the opening and closing of the stomata.
3	Meristem tissue	Plant tissue found at the tips of roots and shoots made of actively dividing cells that can differentiate.
4	Palisade mesophyll	A plant tissue that contains lots of chloroplasts to carry out photosynthesis.
5	Phloem	A plant tissue that transports dissolved sugars from the leaves to other parts of the plant.
6	Spongy mesophyll	A plant tissue that contains large air spaces and has a large surface area for diffusion
7	Stomata	Small openings in the surface of a leaf that allow gases to diffuse into the leaf.
8	Translocation	The movement of dissolved sugars from the leaves to the rest of the plant, via the phloem.
9	Transpiration	The loss of water vapour through the stomata.
10	Xylem	A plant tissue that transports water and mineral ions from the roots to the stems and leaves.

11	Leaf structure
----	----------------

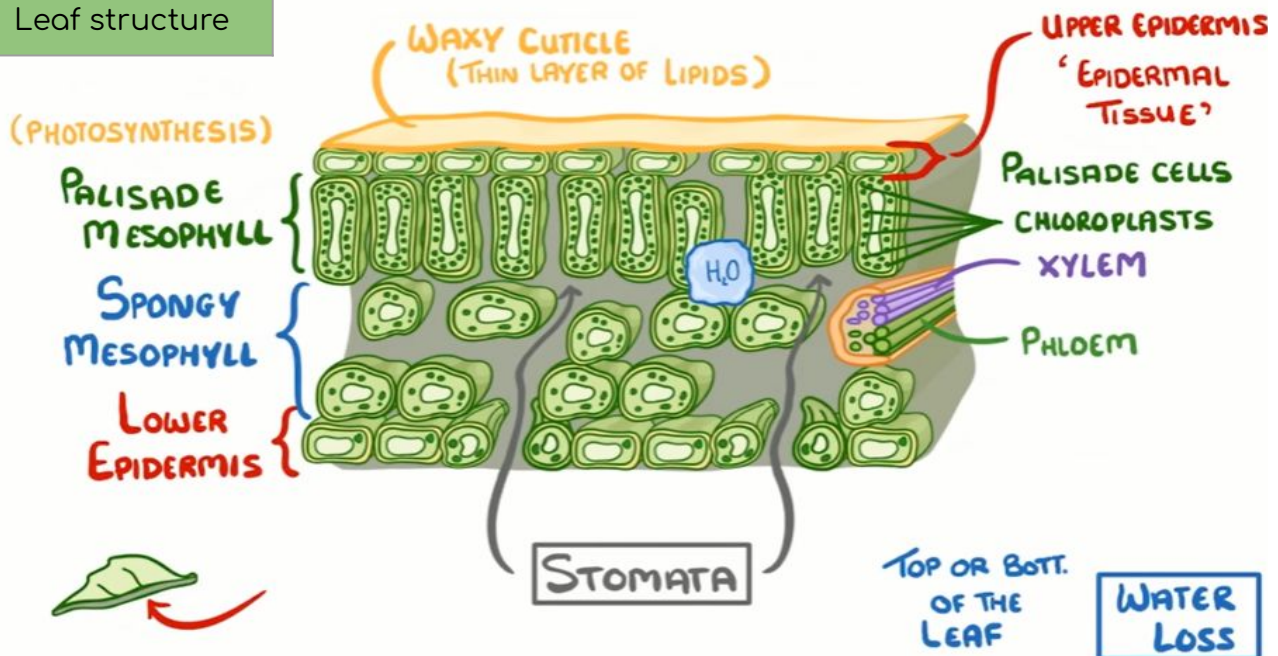

Chemistry

# GCSE Structure and bonding

Learned	Revised	Confident
_____ % Achieved: _____		

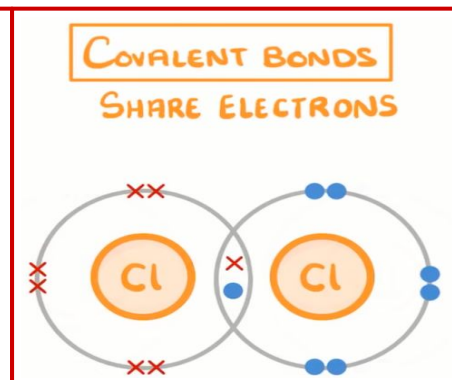
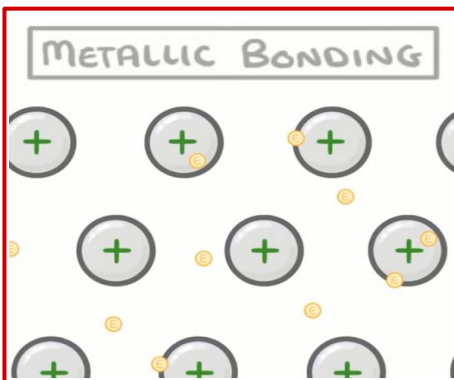

## IONIC BONDS TRANSFER OF ELECTRONS

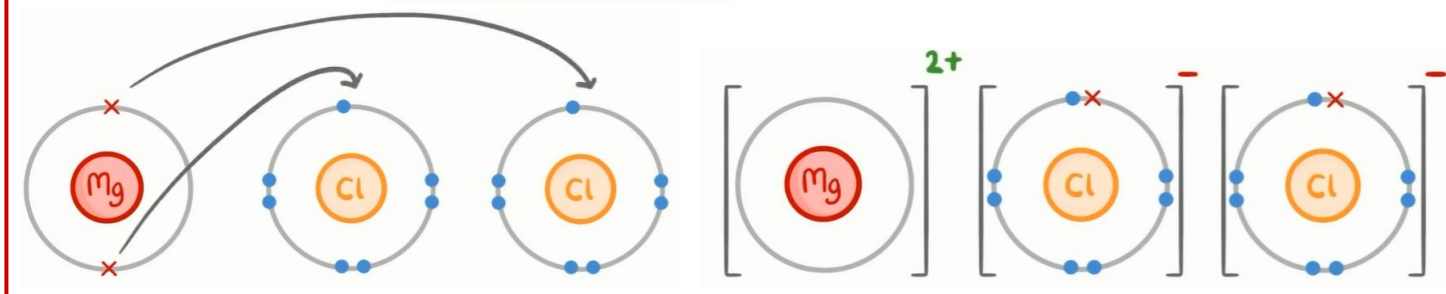











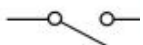

Nº	Keyword	Definition
1	Delocalised electron	An electronic that isn't associated with an atom or bond, it is free to move through the structure
2	Metallic bond	Giant structure of positive metal ions in a sea of delocalised electrons-forming strong electrostatic forces of attraction
3	Ionic bond	Strong electrostatic forces of attraction between oppositely charged ions (formed from the transfer of electrons)
4	Covalent bond	Shared pair(s) of electrons between non-metal atoms
5	Electrostatic forces	Strong forces of attraction between oppositely charged particles e.g. ions and/or electrons
6	Intermolecular forces	Weak forces of attraction that occur between molecules.

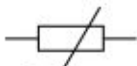
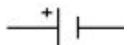
Nº	Fact
5	In bonding, atoms look to gain a full outer shell of electrons. They can lose electrons to drop down a shell, gain to fill their shell or share electrons between their outer shell
6	In ionic bonding, the metal atom loses electron(s) to become a positive ion, the non-metal gains the electron to become a negative ion. These ions then form a giant structure.
7	In covalent bonding, atoms share pairs of electrons to fill their outer shells. This can form a simple molecule (e.g. H <sub>2</sub> O) or a giant structure like diamond.
8	The properties of a substance relate to its structure and bonding. For example, giant structures will generally have high melting and boiling points whereas small, simple structures will have low melting and boiling points

# Physics

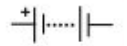
# GCSE Electricity

Learned	Revised	Confident
_____ % Achieved: _____		

 Switch (open)	 Lamp	1 Circuit symbols	
 Switch (closed)	 Fuse	 Diode	 Thermistor
 Cell	 Voltmeter	 Resistor	 LDR
 Battery	 Ammeter	 Variable resistor	 LED

Nº	Keyword	Definition
2	Current	Flow of charge, measured in amperes (A)
3	Potential difference	A measure of how much energy is transferred between two points in a circuit, measured in volts (V)
4	Resistance	Anything that opposes the flow of charge (eg, electrons colliding with ions in the wire), measured in Ohms ( $\Omega$ )
5	Series circuit	Every component is connected in a line (one "loop")
6	Parallel circuit	Every component is connected to the battery separately (it has multiple "loops")

## 7 Series circuit rules

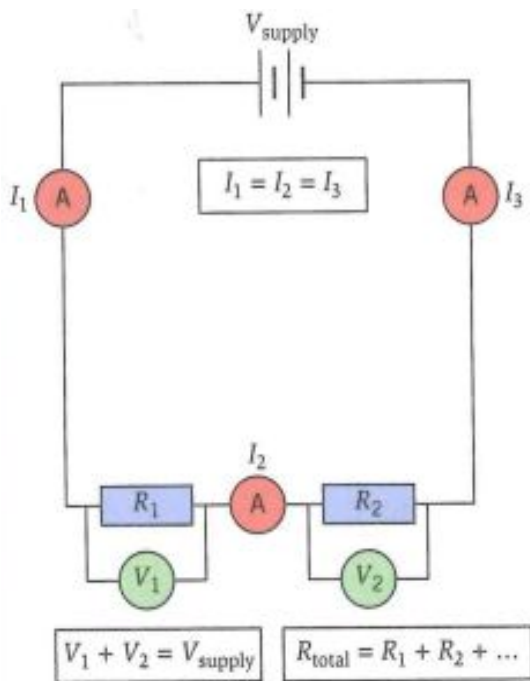

## 8 Parallel circuit rules

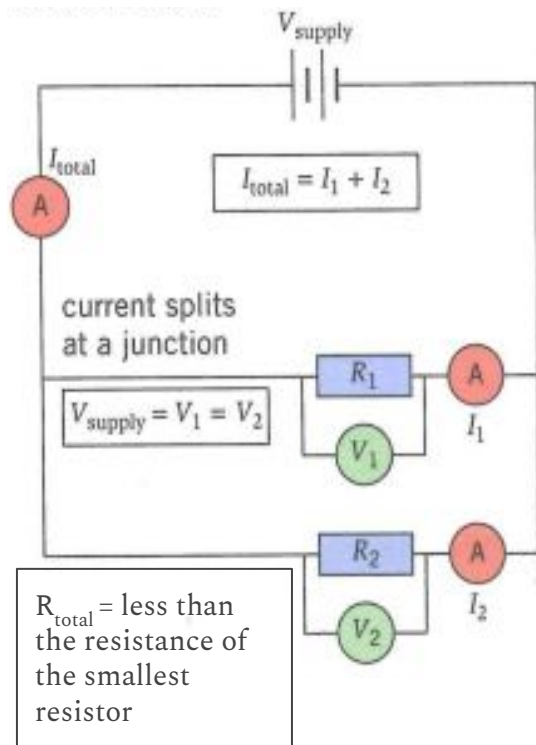

Nº	Equations to learn
9	charge flow = current $\times$ time
10	potential difference = current $\times$ resistance

# GCSE Electricity (2)

1

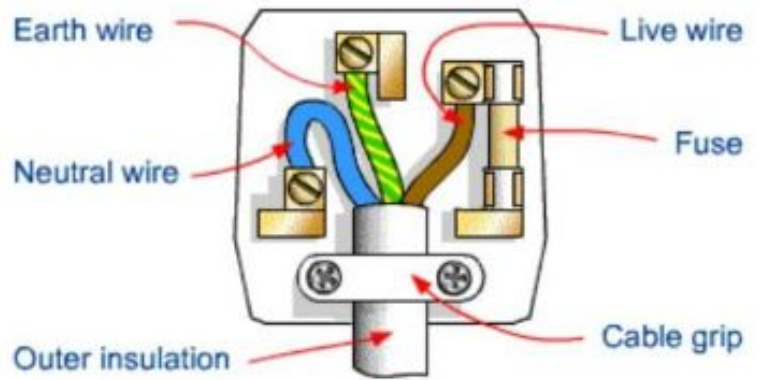

Learned	Revised	Confident
_____ % Achieved: _____		

N°	Keyword	Definition
2	Alternating current	Current that changes direction
3	Direct current	Current that flows in one direction only
4	Step up transformer	Increases the potential difference and decreases the current (reducing resistance and heat loss, and increasing efficiency)
5	Step down transfer	Decreases the potential difference to a safe level (230V for homes).
6	The national grid	A network of cables and transformers that links electricity power stations to consumers

N°	Facts
7	UK alternating current has a potential difference of 230 V and a frequency of 50 Hz

8 The National Grid

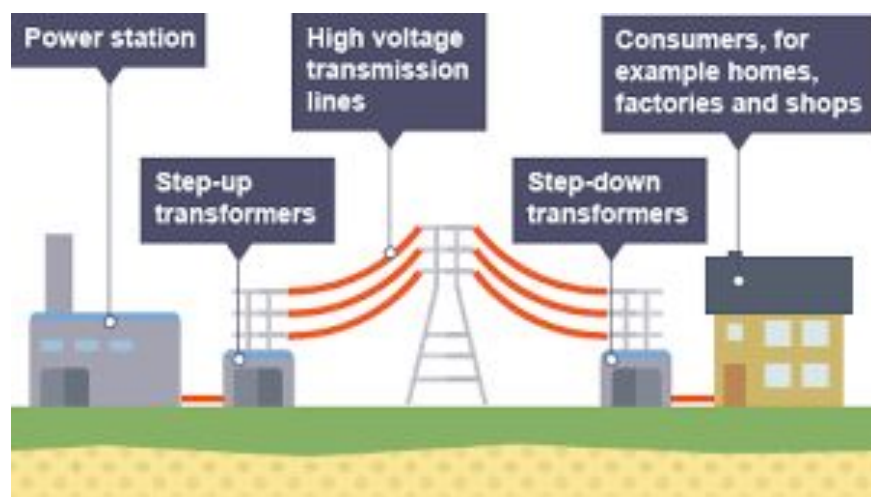

N°	Equations to learn
9	power = potential difference × current
10	power = (current) <sup>2</sup> × resistance
11	energy transferred = power × time
12	energy transferred = charge flow × potential difference