

**Edward Peake Church of England Middle School**

**Textiles**

**Topic: Sewing machine applique**

**Year: 7**

What should I already know?

- How to produce design ideas.
- How to work safely in the textiles room.
- How to produce a range of stitches using hand embroidery.
- How to join two pieces of material together.
- How to evaluate a completed product.

What will know by the end of the unit?

- How to make a prototype.
- How to use a pattern to mark out different shapes.
- How to use scissors to cut fabric.
- How to follow a production plan to make a product.
- How to use the appropriate materials and tools to prepare and apply applique shapes.
- How to use the sewing machine for straight and zigzag stitches.
- How to use the iron to press material.
- How to pin, tack and oversew.

**Vocabulary**

Applique	Pieces of fabric are stuck or sewn onto a larger piece to make a picture or pattern.
Bobbin	A cylinder used for holding thread for a sewing machine.
Pinning	When something is attached or fastened with pins.
Tacking	When pieces of material are fastened together temporarily with long stitches.
Oversewing	When the edges of something are sewn with every stitch passing over the join.
Pressing	When pressure is applied with the iron to smooth the material out.
Seam	A line where two pieces of fabric are sewn together.
Accuracy	The degree to which something is correct.
Production Plan	The stages of making a product.

## Edward Peake Church of England Middle School

Textiles

Topic: Sewing machine applique

Year: 7

### Cotton



A natural plant based material.

Can be dyed so it is available in a wide range of colours and patterns.



### Key information

- Applique is when pieces of fabric are stuck or sewn onto a larger piece to make a picture or pattern.
- A bobbin holds the thread in a sewing machine.
- Tacking is when pieces are held in place temporarily with long stitches.
- A seam is where two pieces of fabric are sewn together.
- Pinning is when something is held with pins.

### Parts of a Sewing Machine and How to Thread a Sewing Machine

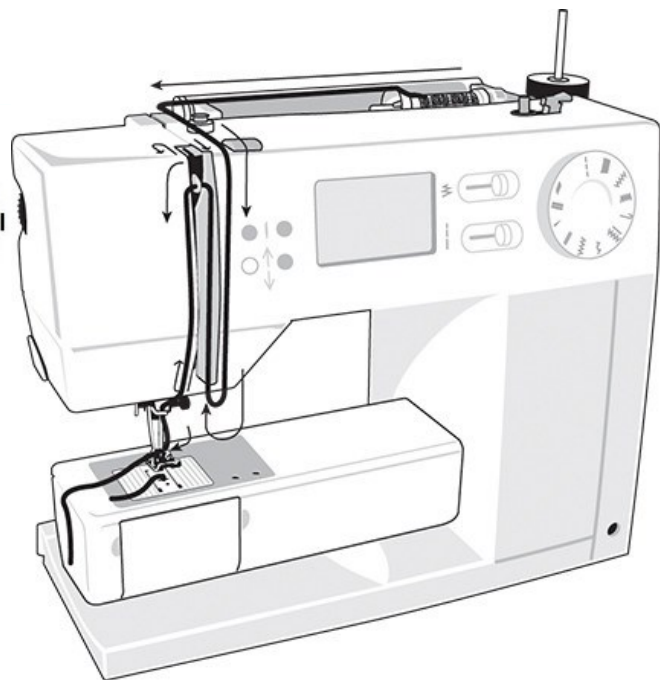
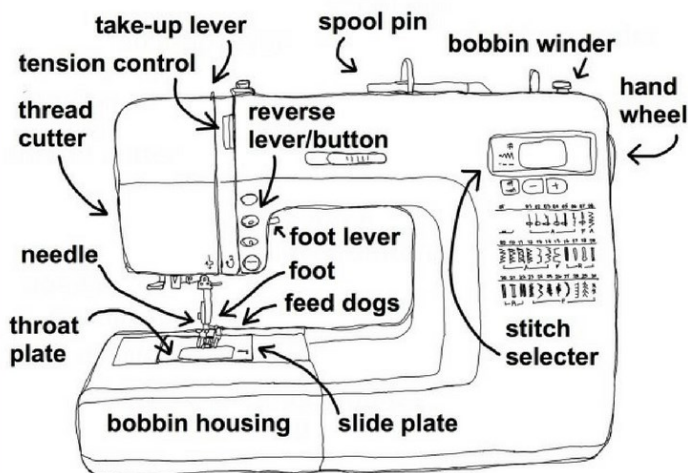

### Investigation tasks

1. Research decorative techniques for use on textiles products and create a fact sheet.
2. Research into textiles recycling and create a poster encouraging people to take part.
3. Make a product of your choice from recycled textiles.
4. Produce a step by step guide explaining how to use the sewing machine to make an appliqued product.