

# Acids and Alkalis Cut-Out Sheet

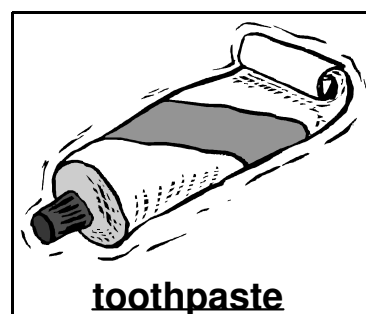
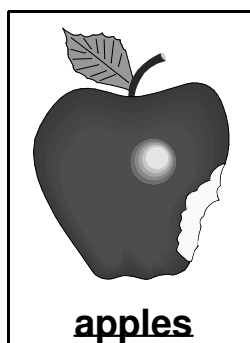
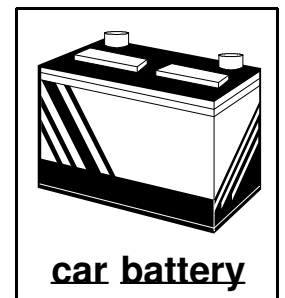
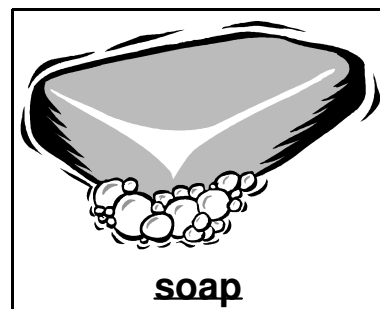
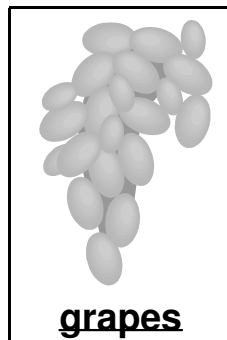
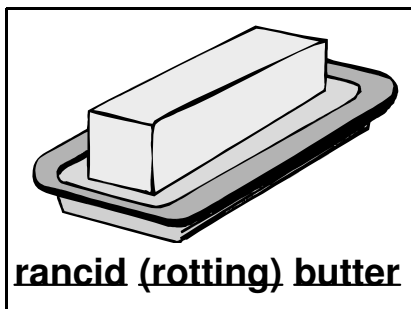
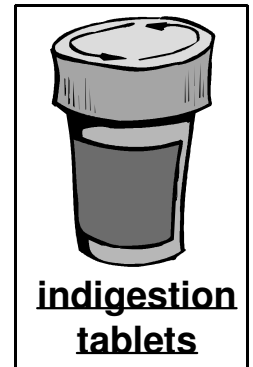
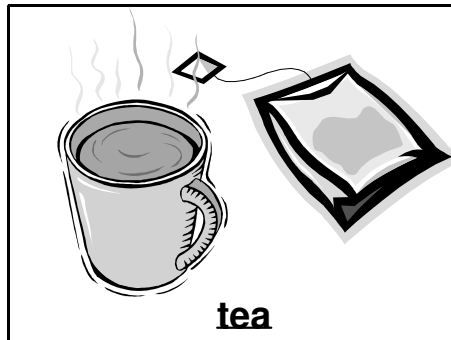
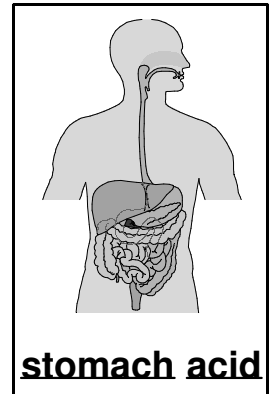
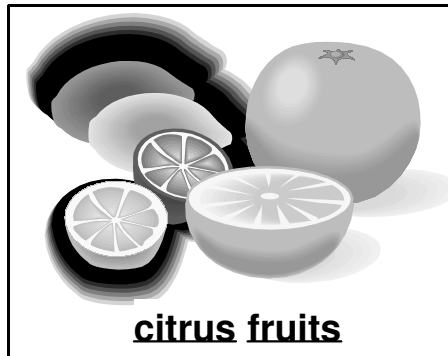
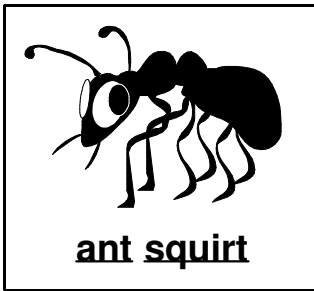
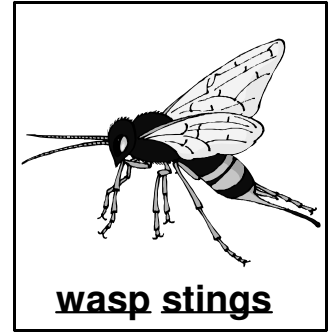
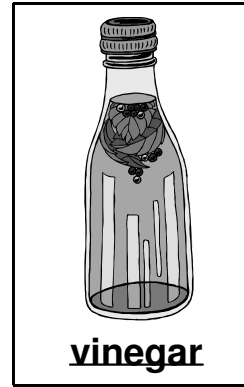
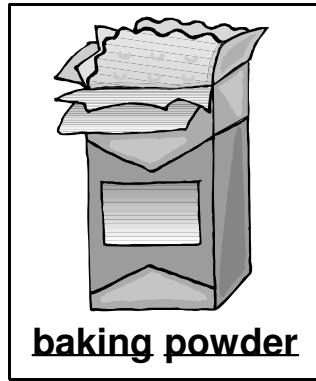
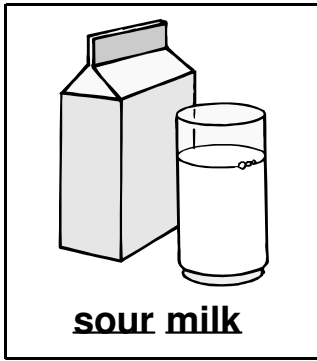

# **Acids and Alkalis Cut-Out Sheet**

nitric acid

sulphuric acid

ethanoic acid

citric acid

methanoic acid

tannic acid

phosphoric acid

lactic acid

butanoic acid

hydrochloric acid

malic acid

tartaric acid

---

nitric acid

sulphuric acid

ethanoic acid

citric acid

methanoic acid

tannic acid

phosphoric acid

lactic acid

butanoic acid

hydrochloric acid

malic acid

tartaric acid

---

nitric acid

sulphuric acid

ethanoic acid

citric acid

methanoic acid

tannic acid

phosphoric acid

lactic acid

butanoic acid

hydrochloric acid

malic acid

tartaric acid

# Front Cover

# **Inside Front Cover**

## • Corrosive Acids and Alkalis

Some acids and alkalis are **corrosive**. What does **corrosive** mean? \_\_\_\_\_

Where might you see this **safety symbol**? \_\_\_\_\_



What does the symbol mean? \_\_\_\_\_

When we use acids and alkalis, what must we always wear? \_\_\_\_\_

Explain why: \_\_\_\_\_

**You should now do EXPERIMENT 1**

## • Universal Indicator

To tell if a chemical is an acid or an alkali, we can use:



or

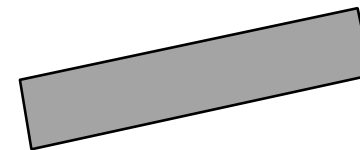

What colour do **acids** turn **universal indicator**? \_\_\_\_\_

What colour do **alkalis** turn **universal indicator**? \_\_\_\_\_

A chemical turns **universal indicator green**. Is the chemical an **acid** or an **alkali**? \_\_\_\_\_

What word can we use to describe the chemical? \_\_\_\_\_

# • Universal Indicator Colours and pH Numbers

Each colour **universal indicator** can turn is given a \_\_\_\_ **number**. These go from \_\_\_\_ to \_\_\_\_.

What does a chemical's **pH number** tell us about the chemical? \_\_\_\_\_

All the numbers together form a \_\_\_\_ \_\_\_\_\_.

What does a **pH scale** measure? \_\_\_\_\_.

Colour the **pH scale** and fill in the missing words below:

pH	1	2	3	4	5	6	7	8	9	10	11	12	13	14
Colour	R e d	→	O r a n g e	→		Y e l l o w	G r e e n	→		B l u e	→		P u r p l e	

Strong  ACIDS  Weak

The \_\_\_\_\_ the acid, the  
\_\_\_\_\_ the pH number.

N  
e  
u  
t  
r  
a  
l

Weak  ALKALIS  Strong

The \_\_\_\_\_ the alkali, the  
\_\_\_\_\_ the pH number.



Complete the labels on the bottles to show **acids** you will often find in a chemistry lab:

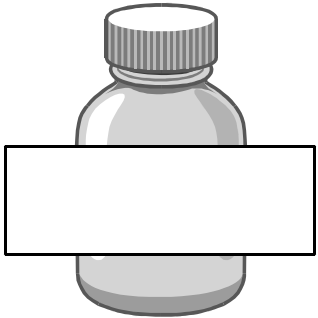
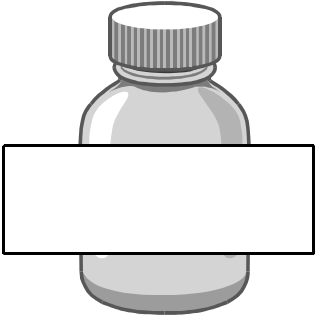
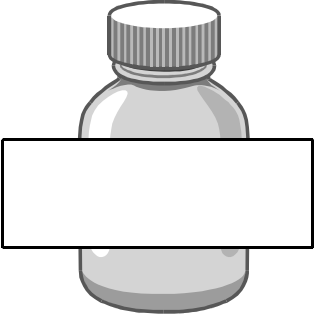
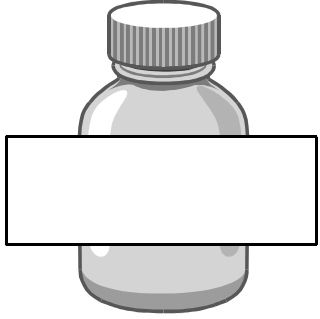

Collect an "**acids and alkalis cut out sheet**". 1) Stick all the **acid pictures** in the space below. 2) Stick the correct **acid name** under each picture.

## **ACIDS**



Stick all the **alkali pictures** in the space below:

## **ALKALIS**

Complete the labels on the bottles to show **alkalis** you will often find in a chemistry lab:

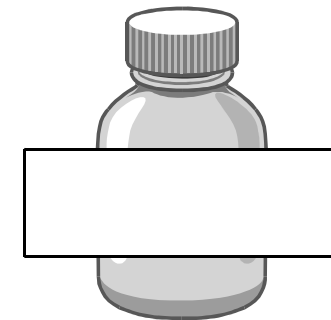
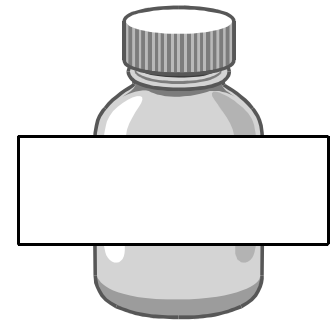
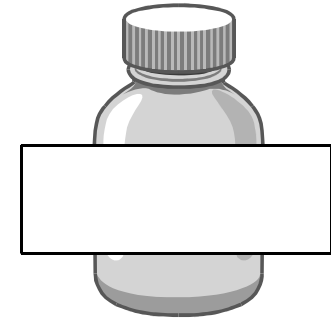

## • Neutralisation

How can you **cancel out** an acid or an alkali? \_\_\_\_\_

\_\_\_\_\_  
\_\_\_\_\_

What word describes the solution formed? \_\_\_\_\_

What is meant by "neutralisation"? \_\_\_\_\_

\_\_\_\_\_  
\_\_\_\_\_  
\_\_\_\_\_

How does **neutralisation** change the **pH number** of an **acid**?

\_\_\_\_\_  
\_\_\_\_\_

How does **neutralisation** change the **pH number** of an **alkali**?

\_\_\_\_\_  
\_\_\_\_\_

**You should now do  
EXPERIMENTS 4 + 5**

## • Everyday Examples of Neutralisation



Are **wasp stings** **acid** or **alkali**?

\_\_\_\_\_

How can we **neutralise** them?

\_\_\_\_\_  
\_\_\_\_\_



What does **acid** in our mouths do to our **teeth**?

\_\_\_\_\_

How do we **neutralise** the **acid**?

\_\_\_\_\_  
\_\_\_\_\_



What does **acid rain** do to the **soil**?

\_\_\_\_\_

How do we **neutralise** the **soil**?

\_\_\_\_\_  
\_\_\_\_\_



Are **bee stings** **acid** or **alkali**?

\_\_\_\_\_

How can we **neutralise** them?

\_\_\_\_\_  
\_\_\_\_\_



If our stomach makes too much **acid**, how do we feel?

\_\_\_\_\_

How do we **neutralise** the **acid**?

\_\_\_\_\_  
\_\_\_\_\_

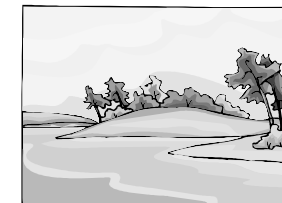

What does **acid rain** do to **lake water**?

\_\_\_\_\_

How do we **neutralise** the **lake water**?

\_\_\_\_\_  
\_\_\_\_\_

## • Products of Neutralisation

When an **acid neutralises** an **alkali**, what 2 things are formed?

\_\_\_\_\_

Name the 2 substances formed when **hydrochloric acid solution neutralises sodium hydroxide solution**?

\_\_\_\_\_

\_\_\_\_\_

Describe how you could prepare these 2 substances in the lab:

\_\_\_\_\_

\_\_\_\_\_

\_\_\_\_\_

\_\_\_\_\_

\_\_\_\_\_

\_\_\_\_\_

\_\_\_\_\_

\_\_\_\_\_

\_\_\_\_\_

**You should now do  
EXPERIMENT 6**

## • Fossil Fuels Cause Acid Rain



Name 3 **fossil fuels**: \_\_\_\_\_

Where are **fossil fuels burned**? \_\_\_\_\_

\_\_\_\_\_

What is present in the **smoke** and **fumes** given off? \_\_\_\_\_

Where does this go? \_\_\_\_\_

What affect does this have on **rain** which falls from the **clouds**?

\_\_\_\_\_

What do we call such **rain**? \_\_\_\_\_

What damage does this **rain** do to:

(a) Trees: \_\_\_\_\_

(b) Fish and wild animals: \_\_\_\_\_

(c) Metal and stone buildings: \_\_\_\_\_

What is the best way to cause **less acid rain**? \_\_\_\_\_

\_\_\_\_\_



# EXPERIMENT 1

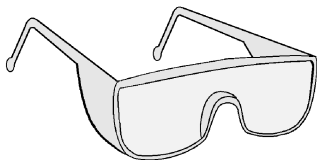

**Acids and alkalis can be corrosive - they can burn your skin and damage your eyes.**

**YOU MUST WEAR SAFETY GLASSES**

**Aim:** To find out \_\_\_\_\_

\_\_\_\_\_

**Method:** \_\_\_\_\_

\_\_\_\_\_

\_\_\_\_\_

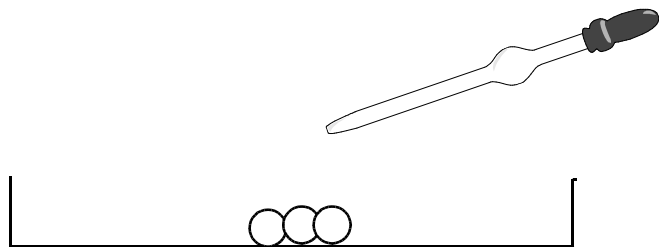

**Observations:** \_\_\_\_\_

\_\_\_\_\_

**Conclusion:** \_\_\_\_\_

\_\_\_\_\_

**Aim:** To find out \_\_\_\_\_

\_\_\_\_\_

**Method:** \_\_\_\_\_

\_\_\_\_\_

\_\_\_\_\_

\_\_\_\_\_

**Observations:** \_\_\_\_\_

\_\_\_\_\_

**Conclusion:** \_\_\_\_\_

\_\_\_\_\_



# EXPERIMENT 2

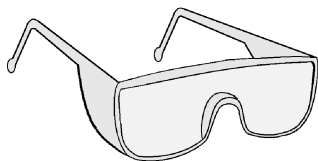

**Acids and alkalis can be corrosive - they can burn your skin and damage your eyes.**

**YOU MUST WEAR SAFETY GLASSES**

**Aim:** To find out \_\_\_\_\_

---

---

---

**Method:** \_\_\_\_\_

---

---

---

---

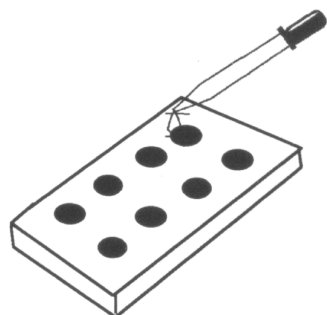

Observations and Results:

<b>Chemical</b>	<b>Colour it turns pH indicator</b>	<b>pH number</b>	<b>acid or alkali or neutral</b>

# **EXPERIMENT 3**

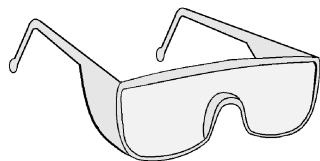

**Acids and alkalis can be corrosive - they can burn your skin and damage your eyes.**

**YOU MUST WEAR SAFETY GLASSES**

**Aim:** To \_\_\_\_\_

\_\_\_\_\_

**Method:** \_\_\_\_\_

\_\_\_\_\_

\_\_\_\_\_

\_\_\_\_\_

**Results:** \_\_\_\_\_

\_\_\_\_\_

\_\_\_\_\_

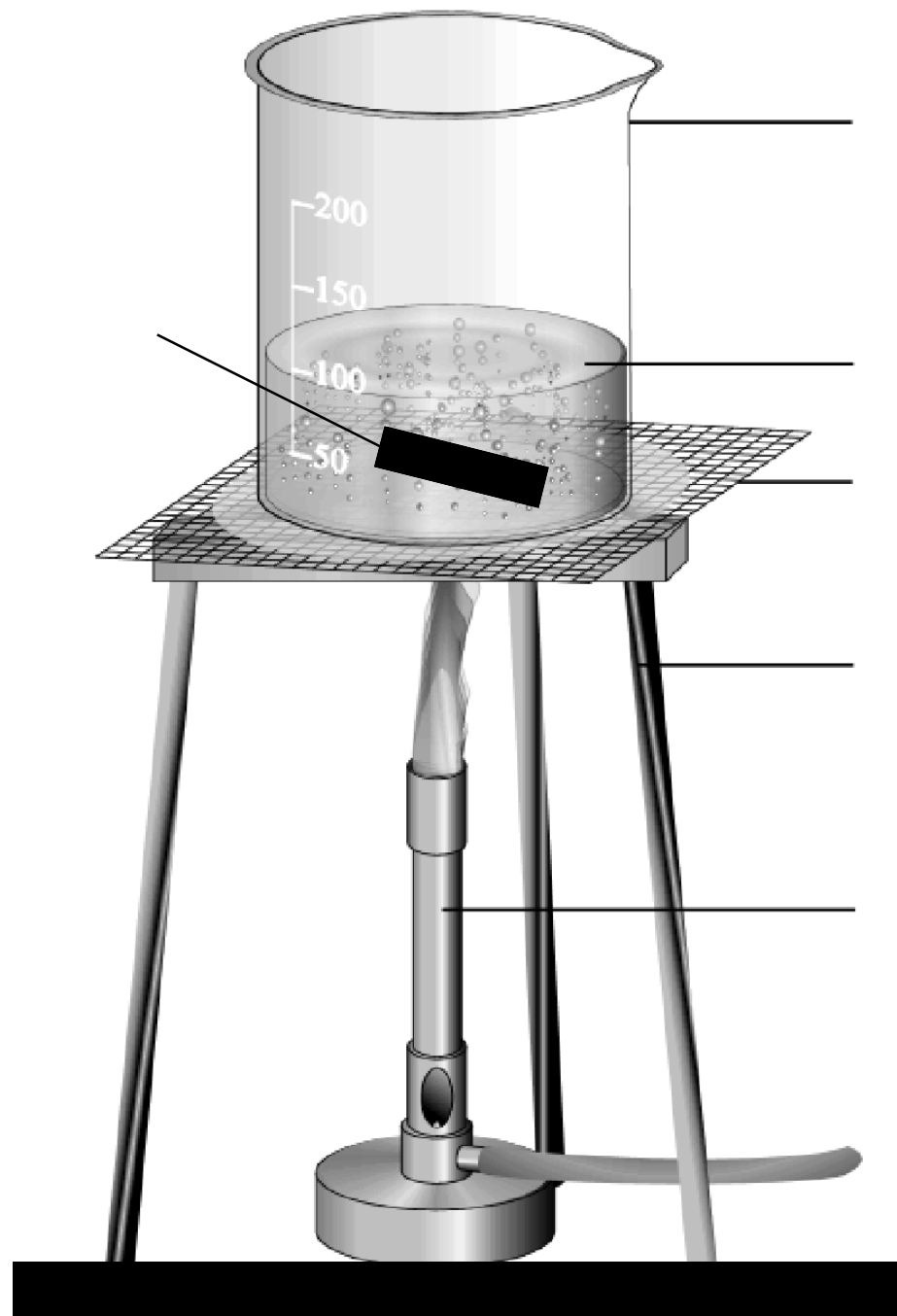

# **EXPERIMENT 4**

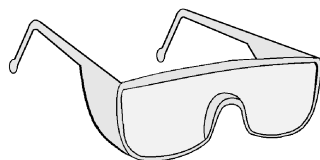

**Acids and alkalis can be corrosive - they can burn your skin and damage your eyes.**

**YOU MUST WEAR SAFETY GLASSES**

**Aim:** To \_\_\_\_\_

\_\_\_\_\_

**Method:** \_\_\_\_\_

\_\_\_\_\_

**Observations:** \_\_\_\_\_

\_\_\_\_\_

**Conclusion:** \_\_\_\_\_

\_\_\_\_\_

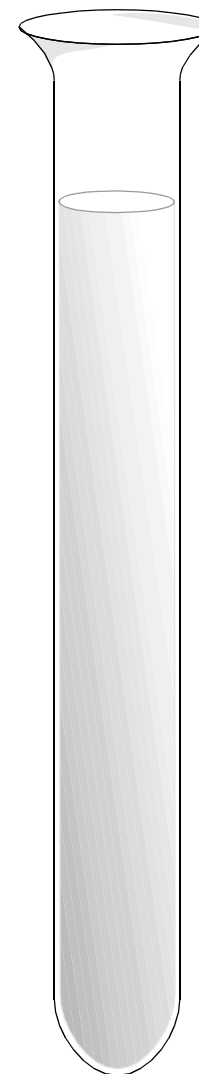
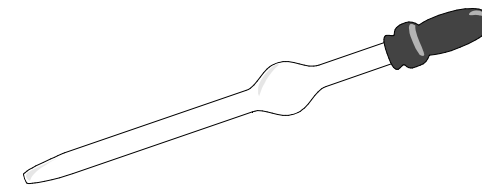



# **EXPERIMENT 5**

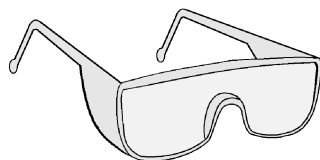

**Acids and alkalis can be corrosive - they can burn your skin and damage your eyes.**

**YOU MUST WEAR SAFETY GLASSES**

**Aim:** To \_\_\_\_\_

\_\_\_\_\_

**Method:** \_\_\_\_\_

\_\_\_\_\_

\_\_\_\_\_

**Observations:** \_\_\_\_\_

\_\_\_\_\_

**Conclusion:** \_\_\_\_\_

\_\_\_\_\_

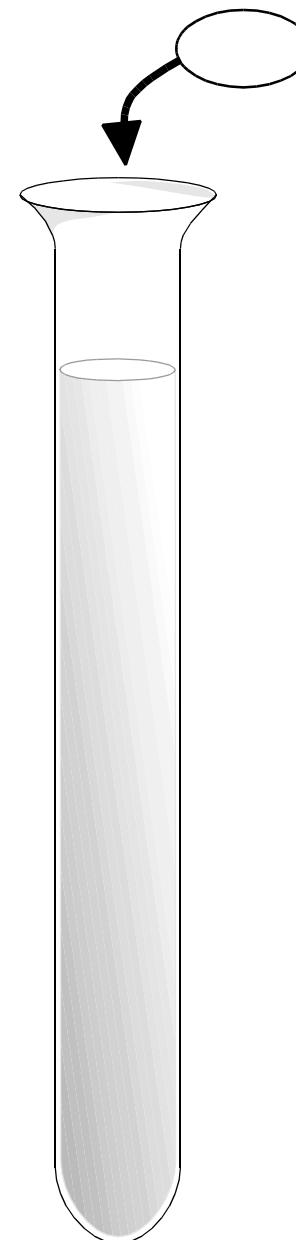

# **EXPERIMENT 6**

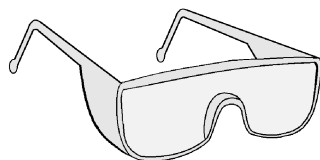

**Acids and alkalis can be corrosive - they can burn your skin and damage your eyes.**

**YOU MUST WEAR SAFETY GLASSES**

**Aim:** To \_\_\_\_\_

\_\_\_\_\_

**Method:** \_\_\_\_\_

\_\_\_\_\_

**Observations:** \_\_\_\_\_

\_\_\_\_\_

**Conclusion:** \_\_\_\_\_

\_\_\_\_\_

**1)**

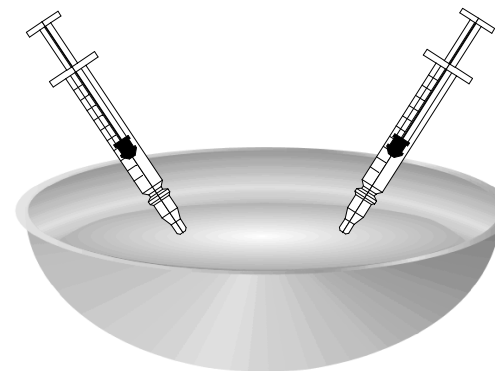

**2)**

