

GCSE Design & Technology - Applied Maths booklet

Topic: Decimal places and significant numbers

1. An engineer requires 100 m of steel cable.

(a) How could this be represented in:

(i) millimetres?

(ii) centimetres?

(b) Explain what happens to the place value of each digit in your answers above in order to convert from metres to cm and mm.

2. The average weight of a member of a user group is 68.54 kg.

Round this figure to the nearest whole number.

Explain how you rounded the number above.

Task 1

1. Calculate the following:

- (a) A student has turned an aluminium tube to an external diameter of 8.45 mm. Write this figure to 1 d.p.

- (b) A teak garden bench has a mass of 30.78 kg. Write the mass to 1 d.p.

- (c) A bag of 500 buttons have a total mass of 235.78 g. Work out the average mass of a button to 2 s.f.

2. A blow moulding machine produces 1200 biodegradable plastic bottles per hour.

The costs and materials for each hour of manufacture are listed below:

- Running costs: £31
- Mass of polymer needed: 21.45 kg
- Volume of polymer needed: 45.47 litres

Based on these figures:

- (a) Calculate the running costs per bottle. Give your answer to 2 d.p.

- (b) Calculate the mass of polymer per bottle in grams. Give your answer to 2 d.p.

- (c) Calculate the volume of polymer per bottle in millilitres. Give your answer to 2 s.f.

3. A family car produces 250 g of CO₂ per km. The car travels 150 km per week on average.

Calculate the total mass of CO₂ produced per year (365 days in a year) by the car. Give your answer in kilograms to 3 s.f.

Task 2

1. Express the following numbers in standard form.

(a) A steel bar with a mass of 156,700 g

(b) A volume of epoxy resin of 0.0045 m³

2. Express the following standard form numbers as ordinary numbers.

(a) An aircraft has wings with a span of 3.58×10^4 mm

(b) The aircraft travels at 9.6×10^2 km/hour

3. The diagram shows a flexible solar cell.



In each square cell, there is a thin wafer of silicon semi-conductor.
The squares have a length of 15 cm and a thickness of 0.25 mm.

Convert both dimensions above into metres. Express both dimensions in standard form.

1. Round the following measurements to the accuracy shown.

(a) The mass of a brass screw is 2.30 g. Give the mass to 1 decimal place. [1]

(b) The length of an aluminium pipe is 101.93 cm.
Give the length to 2 significant figures. [1]

(c) The surface area of the fabric on a trampoline is 2.566 m².
Give the area to 3 s.f. [1]

(d) A 3D printed component requires 32.993 g of polylactic acid (PLA) to be printed.
Give this figure to 2 s.f. [1]

(e) A CNC machine head moves at a speed of 0.239 m/s. Give the speed to 1 d.p. [1]

(f) The mass of a metal bearing is 0.289 g. Give the mass to 2 d.p. [1]

2. This question looks at different flooring costs.

- (a) A hallway in a flat requires a wooden floor of 9.00 m^2 . The engineered wood which is to be laid on the floor costs $\text{£}32.55$ per m^2 .

Work out the total cost of the flooring needed for the hallway.
Give your answer to 3 significant figures.

[2]

- (b) A builder is laying flooring in 100 identical flats. The total cost of the laminate flooring is $\text{£}34,521$. Each flat requires 28.25 m^2 .

Calculate the cost of the flooring for **one** m^2 .
Give your answer to the nearest penny.

[3]

3. The Mars Curiosity Rover landed on Mars in 2012, designed to tour the surface of the planet collecting data.

- (a) The distance from Earth to Mars is $5.46 \times 10^7 \text{ km}$. Write this as a whole number. [1]

- (b) Write this distance in metres. Give your answer in standard form. [1]

- (c) Write this distance in centimetres. Give your answer in standard form. [1]

Topic: Ratio and fractions

Task 1

1. Carbon fibre is a very strong composite material made from thermoset polymer and carbon fibres. It is used to make bike frames, car chassis and running blades.

A bike frame design has a mass of 1.75 kg. If the ratio of polymer to carbon fibre is 3 : 4, calculate the mass of polymer and carbon fibre are needed to manufacture 100 bike frames.

Polymer:	Carbon fibre:

2. Epoxy resin is a thermoset adhesive which is made by adding a resin to a hardener. Study the design of the epoxy resin dispenser below and estimate the ratio of resin to hardener being dispensed.



-
3. A particular type of stainless steel contains the metals iron, nickel and chromium in the ratio of 47 : 35 : 18 by mass.

How much iron, nickel and chromium are present in 20.0 kg of stainless steel?

Task 2

1. Calculate the following:

- (a) A student makes a wooden chair in which $\frac{1}{4}$ of the total cost is teak and $\frac{1}{3}$ of the cost is pine. The remaining costs were made up of components and finishes.

If the total cost of the chair was £52.50, work out the cost of the teak and the cost of the pine to the nearest penny.

- (b) The average car engine weighs 158 kg.

The ratio of the mass of the engine to the mass of the car is 1 : 11.

What is the mass of the car?

2. In a school, there are 40 students studying GCSE Design and Technology this year. The number of students studying GCSE Design and Technology this year is an increase of $\frac{1}{4}$ on the numbers studying the course the previous year.

How many students studied the course the previous year?

1. A survey is carried out amongst 550 people to gauge public opinion for a planned housing development. The ratio of people who liked the plans to those that did not, was 10 : 1.

How many people liked the building? [2]

2. $\frac{1}{11}$ of the annual budget of a manufacturing company is spent on rivets.

The annual cost of rivets is £390. Work out the annual budget of the company. [5]

3. The ratio of two metals, iron and nickel, present in an alloy were shown to be 4 : 3 respectively. If the alloy has a weight of 50 g, work out the weights of the two metals. [4]

4. A car manufacturer has increased its use of metal sheet by $\frac{1}{10}$ from last year. The manufacturer uses 10,000 sheets this year. How many sheets did they produce last year? Round your answer **up** to the nearest whole sheet. [5]

Topic: Percentages

Task 1

Pure gold is a metal that has many special properties. For example, it is used as a heat shield in some satellites and on electronic circuit boards. Other metals may be added to it to make different types of gold alloy.

Complete the table by working out the missing percentages.

White gold	Gold _____%, palladium 25%
Green gold	Gold 75%, silver 15%, copper 6%, cadmium _____%
Red gold	Gold 75%, copper _____%
Rose gold	Gold _____%, copper 22.5%, silver 2.75%

Task 2

1. Out of a focus group of 30 users, 22 prefer a wood finish to a metal finish. What percentage of users in the focus group prefer the metal finish? Give your answer to 1 d.p.

2. An alloy of solder contains 60% tin and 40% lead by mass. A sample of solder has a mass of 10.5 g. Work out the mass in the solder of:

(a) tin

(b) lead

- (c) A student cuts out a piece of metal sheet with an area of 150 cm² from a sheet of 250 cm². What percentage of the metal is not used?



1. A running vest is made of 80% cotton and 20% Lycra[®] by mass.
If the shirt has a mass of 200 g, what is the mass of Lycra[®] in the shirt? [2]

2. A craftsperson creates a table that is made from a combination of oak, steel and glass.
The mass of steel is 21.5 kg.
The mass of the steel is 60% of the total mass of the table.
What is the total mass of the table? Give your answer to 2 decimal places. [2]

3. The price of stock printing paper has increased by 5%.
The previous price was £300 per m³. Work out the new increased price. [3]

4. Value added tax (VAT) is added as an extra tax to many products.
VAT is worked out at 20% of the price before VAT is added.
- (a) Printed circuit boards are purchased for £30 for a pack of 10, excluding VAT.

What is the price including VAT? [3]

- (b) A CNC vinyl cutter is purchased by a designer for £3,500, including VAT.

What was its price excluding VAT, to the nearest penny? [2]

Task 1

A stained-glass window designer is creating a new window design. To assist with the construction of the window, work out the missing values of angles a to i in the component shapes below.

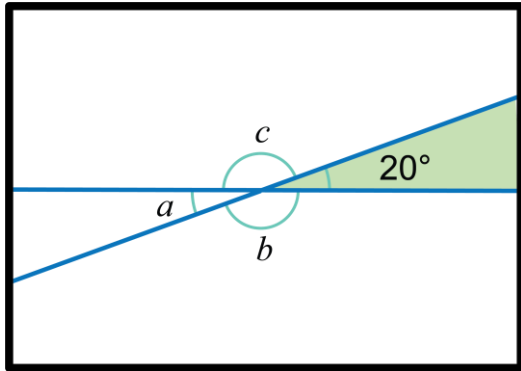

$(a) =$ $(b) =$ $(c) =$

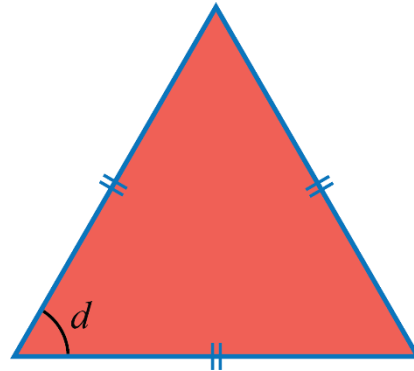

$(d) =$

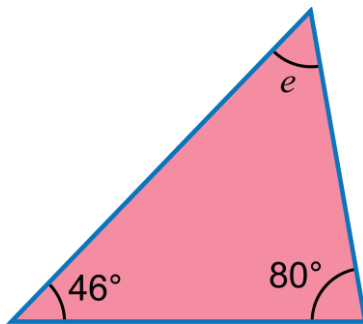

$(e) =$

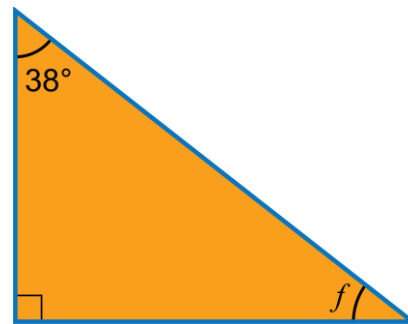

$(f) =$

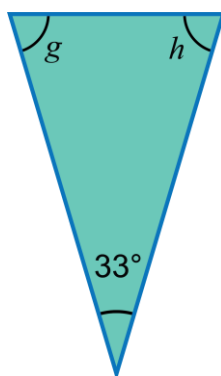

$(g) =$ $(h) =$

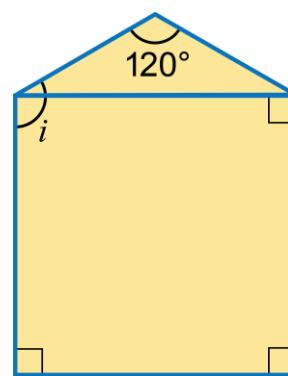

$(i) =$

Task 2

Work out the surface area of the each laser cut acrylic component below.

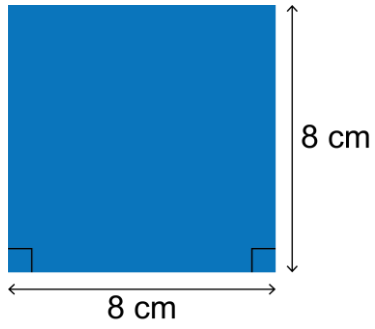

(a)

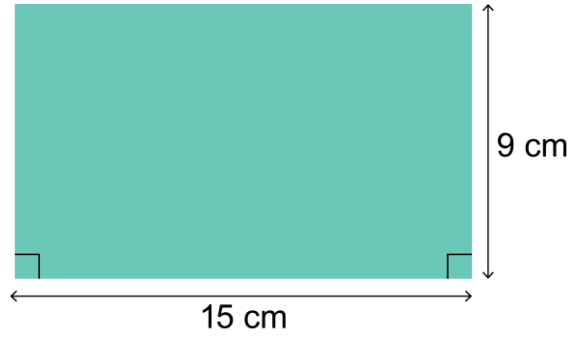

(b)

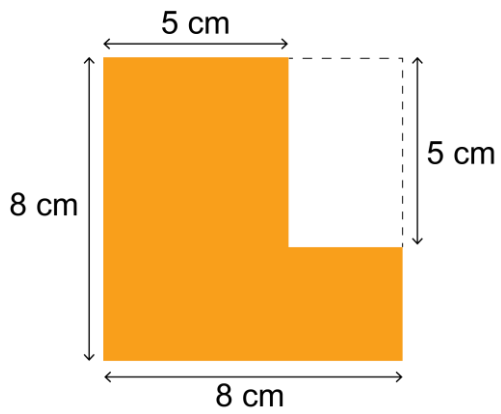

(c)

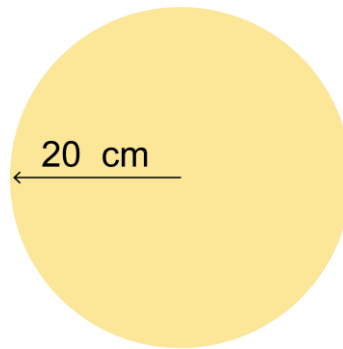

(d)

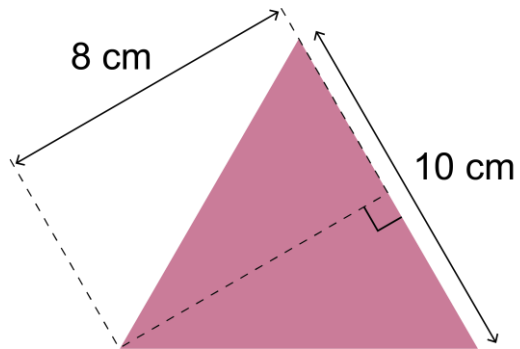

(e)

Task 3

Work out the volume of the following shapes.

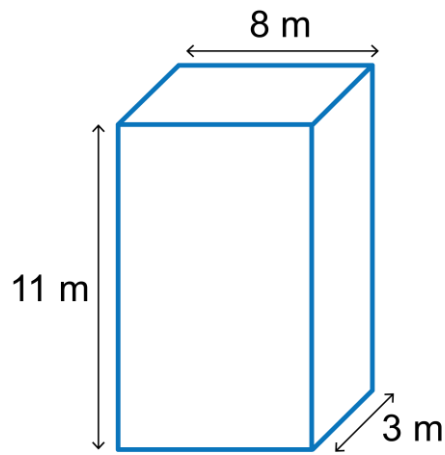

(a)

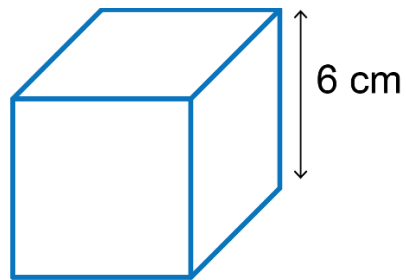

(b) A cube of side 6cm

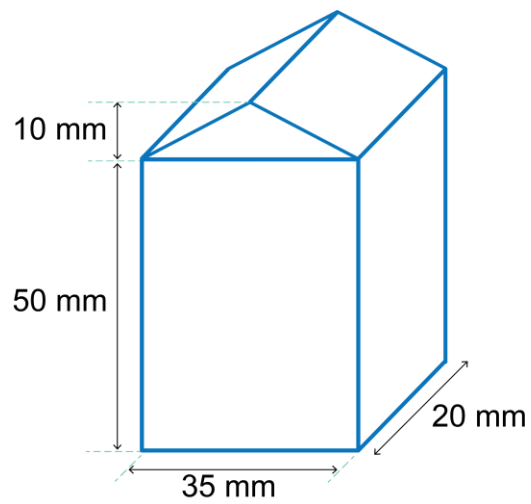

(c)

Task 4

These cardboard tubes have an internal diameter of 11 cm and an external diameter of 13 cm. They have a length of 15 cm.



(a) Work out the external volume of one of these tubes.

(b) Work out the internal volume of one of these tubes.

(c) Use your answer to part (a) and part (b) to work out the volume of cardboard in one of the tubes.

1. Work out the areas of the following table top configurations:

(a) The plan view of two tables.

[3]

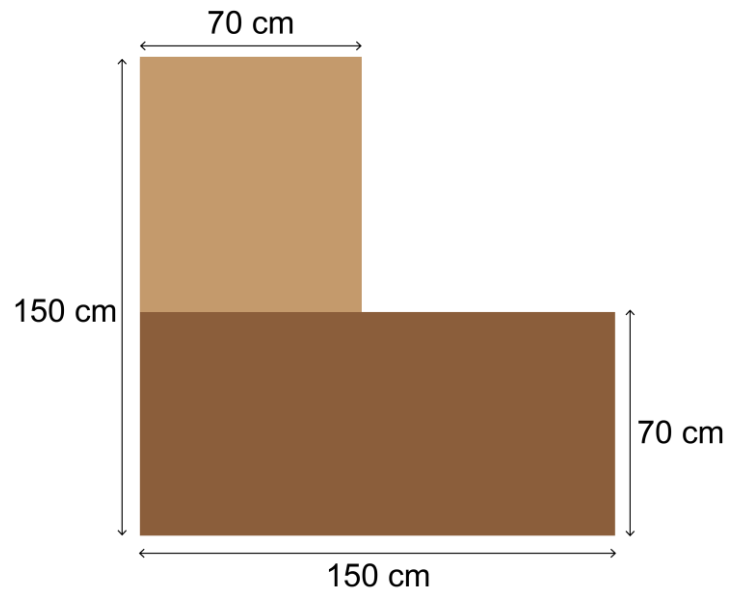

(b) The plan view of an office desk.

[2]

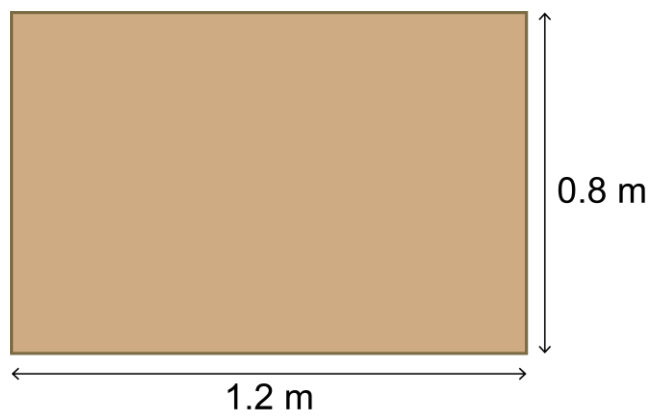

2. Work out the area of the following weed suppressant matting plans for a garden designer.

Let $\pi = 3.14$.

[2]

(a) Work out the area of matting required for the triangular shaped part of the garden.

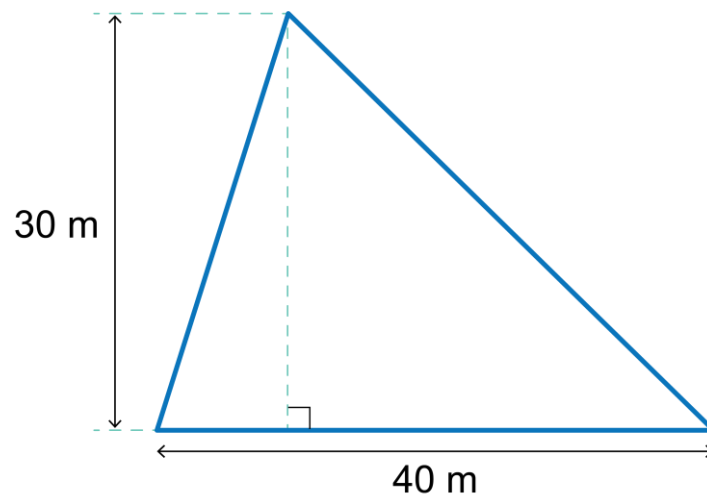

(b) Work out the area of matting needed for a composite shaped flower bed.

[4]

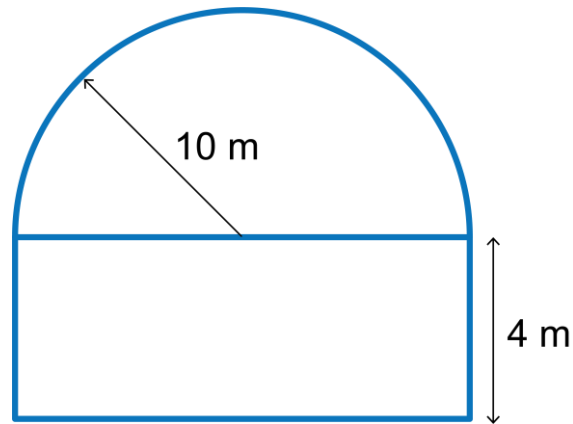

(c) Work out the area of matting needed to go around a large circular garden sculpture.

[4]

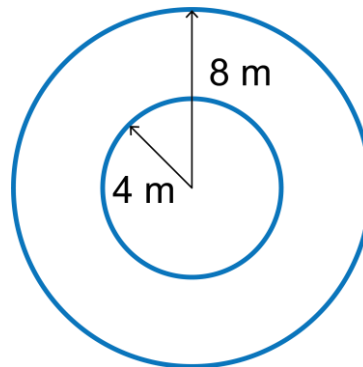

3. Work out the i) surface areas and ii) volumes of the following wooden cubes and cuboids.

(a) Dimensions = 2 cm × 2 cm × 8 cm

[2]



(b) Dimensions = 9 mm × 9 mm × 9 mm

[2]



(c) Dimensions = 1.5 m × 3 m × 0.3 m

[2]



Topic: Working with data

Task 1

Exploring and learning about space can be a very expensive project costing billions of pounds.

A poll is carried out in which people were asked whether they thought that money spent in this way was well spent, or not. The results are summarised in the table below.

Money well spent	180
Money not well spent	150
Not sure	30

(a) How many people were questioned in the poll?

(b) What percentage of people thought that the money was well spent?

(c) What is the ratio of the number of people who thought the was money well spent to the number of people who thought the money was not well spent? Express your ratio in its simplest form

(d) Construct a bar chart below to show the findings. Remember to label the axis.

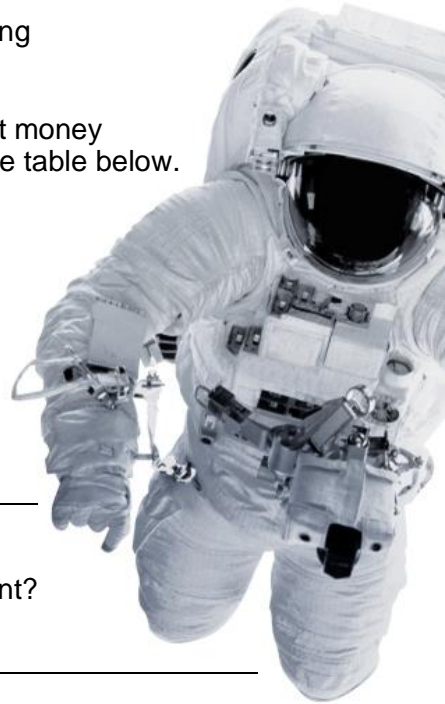

Task 2

The table below gives the weight of lithium metal used to make a range of different products, by a high-tech industry.

Material	Mass per year (tonnes)	Percentage of total
Batteries	117	
Glass and ceramics	93	
Lubricating grease	21	
Casting products	15	
Air treatments	9	
Polymers	12	
Other	33	



- Work out the percentage of the total lithium metal used for each product and add your finding to the table above.
- Using your answers from part (a), construct a pie chart of this data.

Task 3

The following table shows how the speed of a student's 3D printed prototype radio-controlled car varies with time along a straight test track.

Time in seconds	Speed in metres per second
0	0.0
1	0.3
2	1.0
3	2.0
4	2.9
5	3.2
6	3.2
7	3.2



(a) Plot a graph on the space below to show the speed of the car on the vertical axis, against time on the horizontal axis.

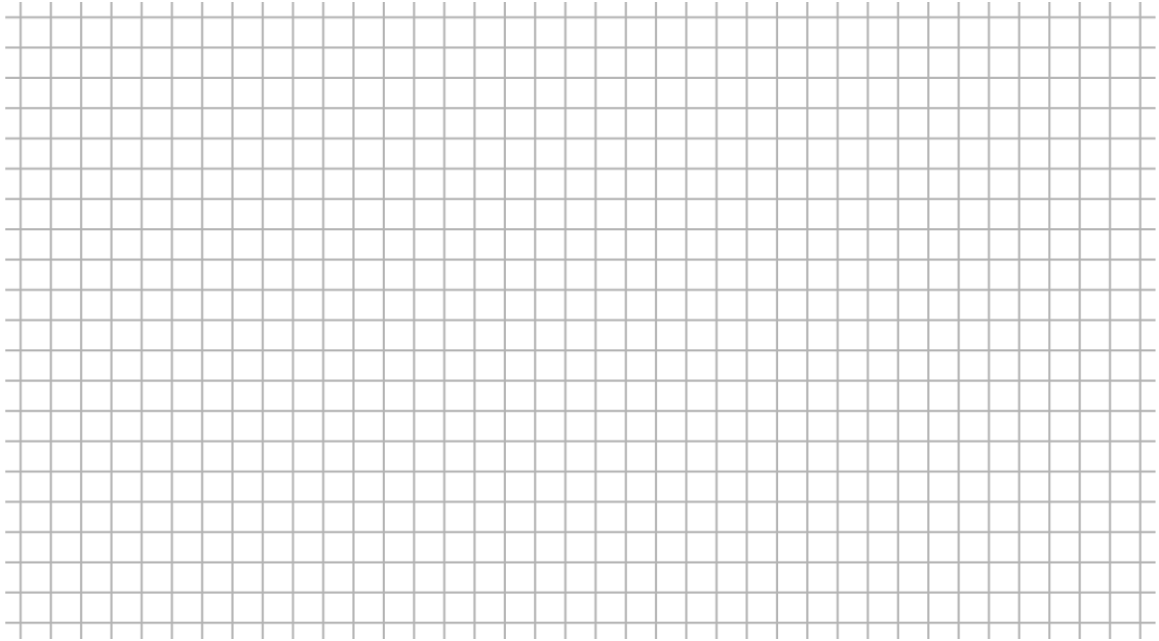

(b) After what time is the car moving at half its maximum speed?

(c) Explain what happens to the speed of the car from the start up to 7 seconds.

1. A large electronics company recently conducted a life cycle analysis (LCA). The results highlighted that a number of harmful waste gases are being released as part of their manufacturing process. The company aims to trap the waste gasses during the manufacturing process. The bar chart below shows the volume (per week) of 5 different gases that were highlighted in LCA.

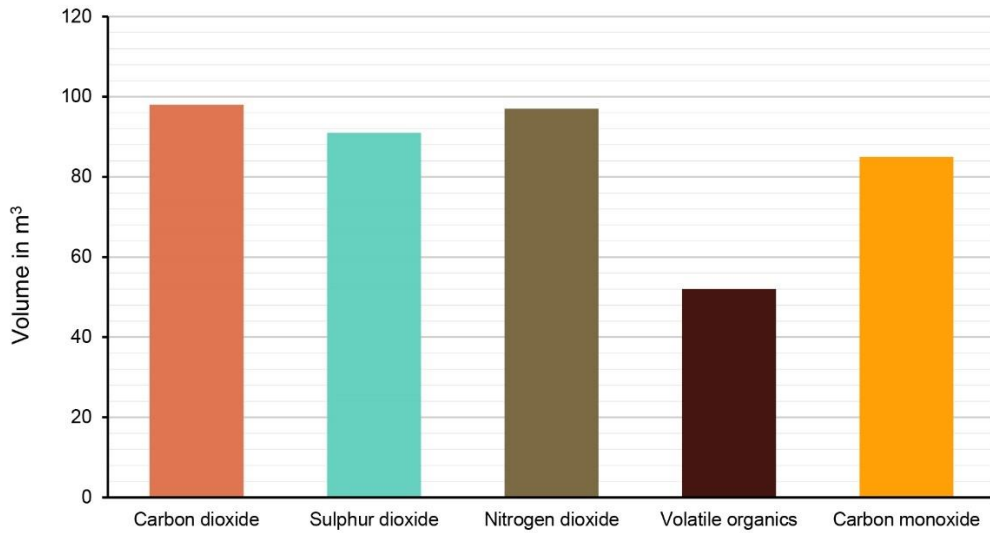

- (a) Using the bar chart, give approximate values for each of the gases produced per week by the company.

[5]

Carbon dioxide	
Sulphur dioxide	
Nitrogen dioxide	
Volatile organics	
Carbon monoxide	

- (b) What is the total volume of gases produced per week?

[2]

- (c) A special chemical filter is fitted to remove the carbon dioxide, sulphur dioxide and nitrogen dioxide gases.
When this happens, what volume of gas still needs to be removed? [2]

- (d) What is the percentage decrease in the volume of gases when the special chemical filter is being used. Give your answer to 1 d.p. [2]

2. A design business wishes to save money by changing 800 of its incandescent light bulbs to a more energy efficient variety.

The table below shows the three main types of bulb being considered. The figures give the power usage of a bulb, in Watts, measured at 1,600 Lumens (how bright they are).

Incandescent 100 W	Compact fluorescent 25 W	LED 18 W
		

	Watts per bulb	Watts per 800 bulbs	Cost in £ per hour	Cost in £ per week
	(a)	(a)	(b)	(c)
Incandescent				
Compact fluorescent				
LED				

Using the table overleaf:

- (a) Work out how much energy is used by 800 of each bulb type and put the data clearly in the table overleaf. [4]
- (b) It costs 10p to use 1,000 W for 1 hour. Work out how much it costs to power 800 of each bulb type for 1 hour. Give your answer in £. [3]
- (c) Given that 800 bulbs are being used 10 hours each day, and for 5 days a week, work out the cost saving of moving from incandescent bulbs to LED bulbs each week. [3]

- (d) Work out the annual cost saving for the design business. Assume that the business operates 45 weeks of the year. [2]

Topic: Solving DT problems

Task 1

A student wishes to make a cone from polypropylene to project sound.

The shape is based on a sector of a circle with radius 30 cm.

The angle marked on the diagram is 120° .

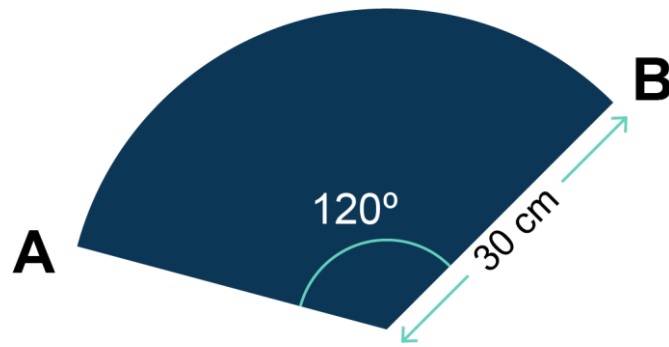

The circumference of a circle is given by $C = \pi d = 2\pi r$, where d is the diameter of the circle, r is the radius. Take π as 3.14.

Give all answers to 1 decimal place.

- (a) Calculate the area of the polypropylene sector.

- (b) Calculate the length of the arc of the sector, that is, the length of the curved part.

- (c) Calculate the total perimeter of the sector, that is, the total length of the outside of the shape.

Task 2

A student draws two parallel lines on the lid of their project so they can accurately place a self-adhesive vinyl logo.

Work out the sizes of angles a , b and c .

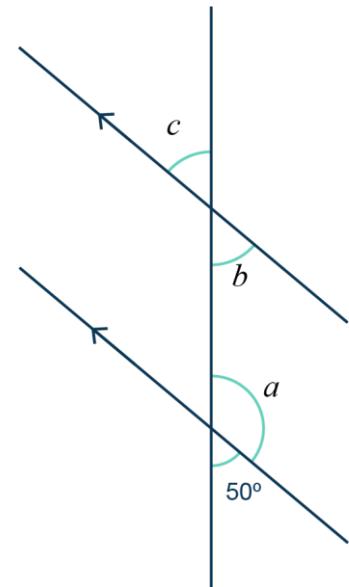

1. A student designs the triangular shape, shown below, that they wish to cut from acrylic sheet to make a mountain themed wall clock for their climbing club.

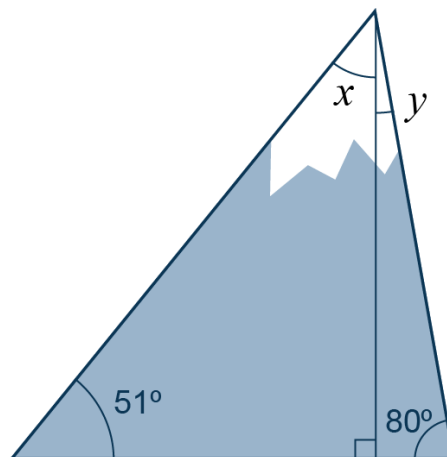

- (a) Work out the angles x and y in the diagram.

[4]

- (b) Given that the base length of the triangular shape is 240 mm and its vertical height is 200 mm, work out the area of the shape in i) mm^2 and ii) cm^2 .

[3]

2. The 3D shape below has been designed to be made from folded card as a point of sale stand for a school project.

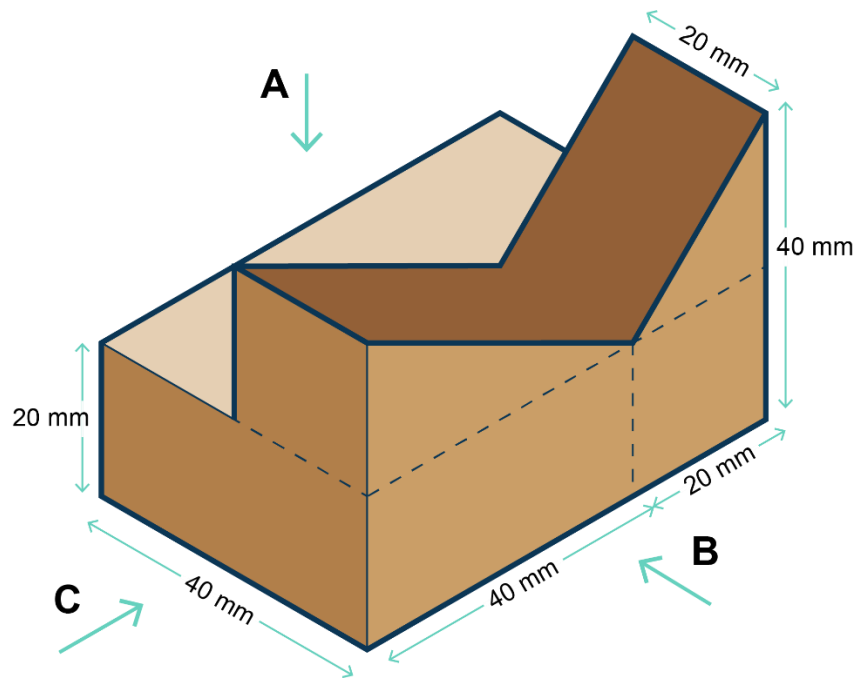

- (a) In 3rd angle orthographic projection, draw the three views that would be seen along each of the arrows A, B and C. Used the grip paper below. [4]

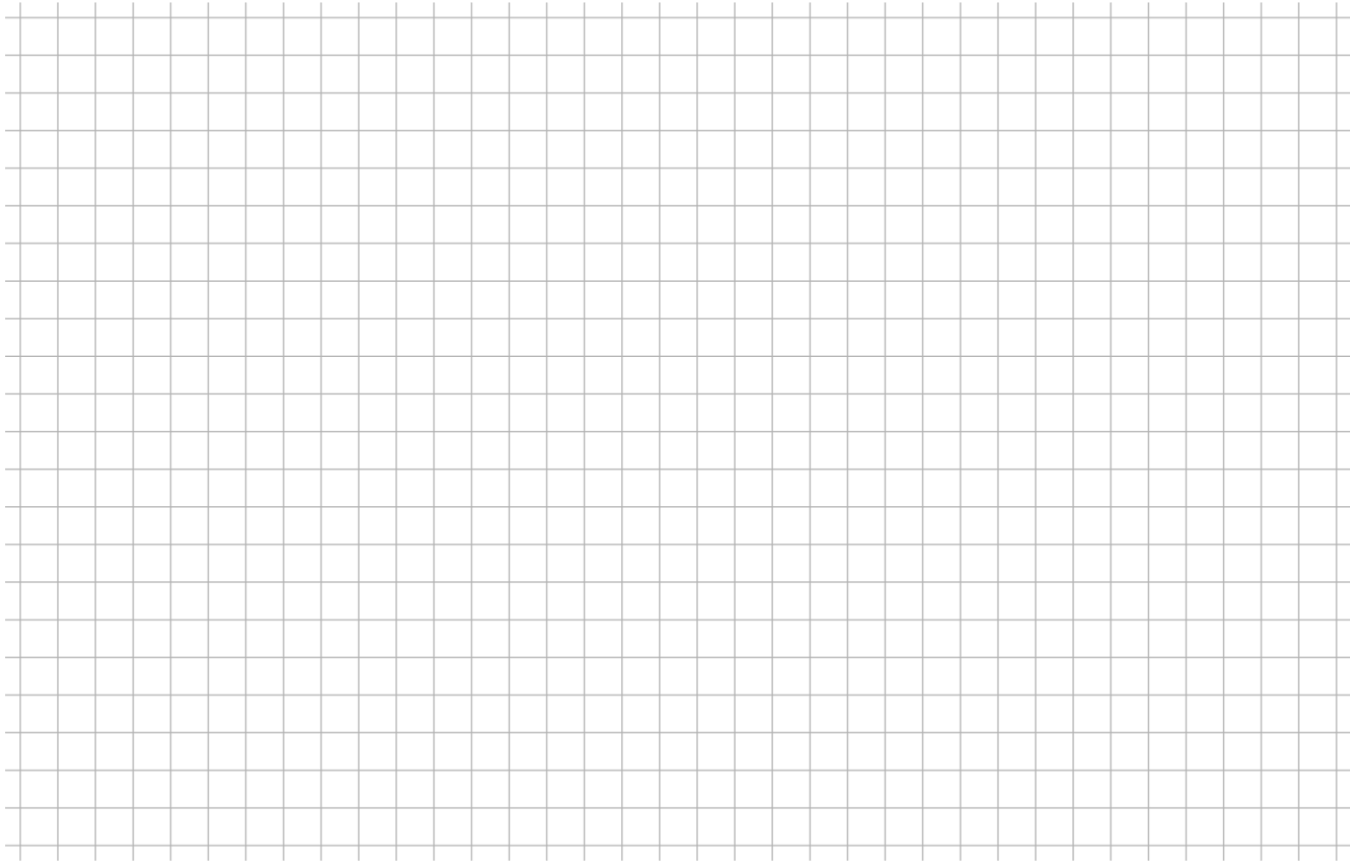

(b) Work out the volume of point of sale stand.

[5]

3. An eco-conscious designer wants to work out how much carbon offsetting they need to purchase in order for their deliveries to be considered carbon neutral.

They have a diesel delivery van that produces 250 g of carbon dioxide for every km travelled when delivering goods. On average the van does 65 km every day for 6 days of every week.

(a) Calculate the mass of carbon dioxide, in kg, produced each week by the van.

[4]

(b) The van operates every week except for 1 week between Christmas and New Year. Calculate the annual CO₂ emissions for the van.

Write your answer in standard form to 2 decimal places.

[2]

Final test – all topics

1. Study the label taken from an item of clothing.

A textiles sample weighing 125 g is analysed as a possible material for an item of sports clothing.

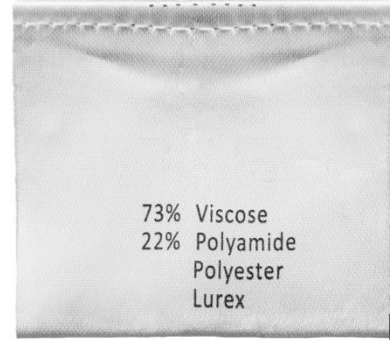

- (a) Work out how many grams of viscose in the fabric sample.

Give your answer to 1 decimal place.

[2]

- (b) What is the combined percentage of polyester and lurex in the fabric?

[2]

- (c) The weight of polyester in the sample is 3.75 g.

What is the ratio of polyester to lurex?

[3]

- (d) Give the ratio for all the different materials in the fabric.

[1]

- (e) A textiles technician wants to order 1.5 kg of the sample fabric for further testing. What is the mass of Polyamide in the new sample?

Give your answer in g.

[2]

2. The following 3D shape consists of 4 separate wooden cubes, each with a side length of 50 mm. They are to be glued together in the pattern shown.

The fourth cube, which adjoins the other three cubes, is not visible in this view.

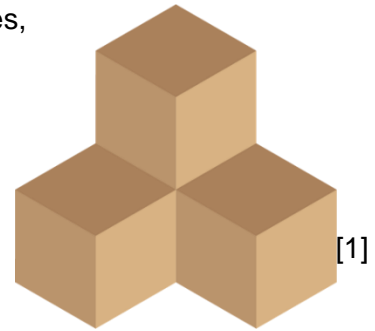

- (a) How many square 50 mm × 50 mm faces do the 4 wooden blocks have all together? [1]

- (b) The whole 3D shape is to be varnished. How many external square 50 mm × 50 mm faces will require varnish? [1]

- (c) Work out the surface area of the shape, giving your answer in standard form. [3]

- (d) Work out the volume of the 3D shape in mm³. [2]

- (e) A student wishes to paint the 3D shape with a non-toxic acrylic which has a coverage of 100 cm² per ml. Work out the volume of paint needed to paint the shape in ml. [2]

3. A professional upcycler purchases some leather to cover an old wooden storage box.



The dimensions of the whole box are 45 cm × 20 cm × 20 cm.
She wishes to cover it with tan leather which costs £35 per m².

(a) What is the surface area of the wooden box in cm²? [2]

(b) Work out the area of leather she needs to use, in m². [2]

(c) How much does it cost to cover the box? [2]

4. Cotton makes up around 33% of all fibres used to make clothes for the fashion industry and accounts for 77% of all-natural fibres produced.

Cotton is a very thirsty crop, needing around 2,700 litres of water to make one cotton T-shirt.

- (a) A clothing manufacturer makes 13,000 cotton T-shirts in 1 year. Work out how much water is used to make this number of shirts. Give your answer in standard form. [3]

- (b) What is the ratio of cotton to all fibres in its simplest form? [1]

- (c) The clothing manufacturer has to increase production by 15% each year for the next 2 years. How many T-shirts will they have to produce each year for the next two years? [4]

5. A designer carried out some market research on preferred materials for a new design of mobile phone case. The results for two of the questions, from two different sample groups, are shown in the tables.



Q1 What material would you prefer the mobile phone case to be made from?

Material	Number of people
Leather	34
Aluminium	45
Polypropylene plastic	12

Q2 How much money would you expect to spend on a mobile phone case?

Price range/£	Number of people
10 - 20	46
21 - 30	24
31 - 40	9

- (a) Work out the percentage of people in Q1 who preferred each material, giving your answers to 1 decimal place. [3]

Material	Number of people	% of people
Leather	34	
Aluminium	45	
Polypropylene plastic	12	

- (b) The designer concludes that most people are likely to expect to spend between £10 and £20 on a mobile phone case. Work out the exact percentage of people who would be prepared to spend up to £20. Give your answer to 1 decimal place. [1]

- (c) The designer works out that they can make 500 mobile phone cases for £2.50 each. They hope that most people would be willing to spend £12.50 on a case, so aims to sell them at this price.

i) How much does it cost them to manufacture 500 mobile phone cases? [1]

ii) If they sell all 500 cases, work out the profit in pounds. [2]

iii) Work out the percentage profit.

[2]

6. Study the picture of the acrylic menu stand below.

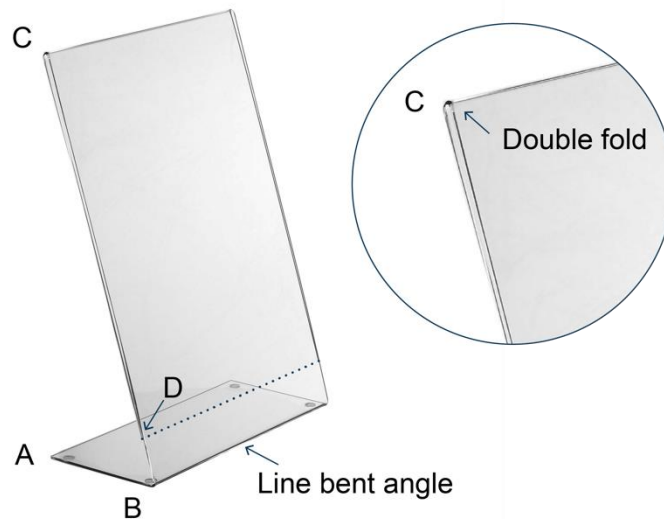

- The profile of the acrylic stand forms a right-angled triangle.
- The angle ABC is 80° .
- The length of line AB is 100 mm and line BC is 292 mm.
- The stand has been shaped using a line bender and from C to point D the acrylic is folded double (back on itself) to hold the A5 portrait menu in place

(a) What is the size of the angle ACB?

[2]

(b) A4 card is 210 mm x 297 mm. What is the size of A5?

[1]

(c) If CD is exactly the longest length of the A5 sheet plus 18 mm, what is the total length of the piece of acrylic? [2]

(d) What is the ratio of the base compared to the total length of the acrylic piece, in its simplest form? [1]

(e) If the menu holder is 148 mm wide, what is the surface area of the acrylic sheet? [2]
