

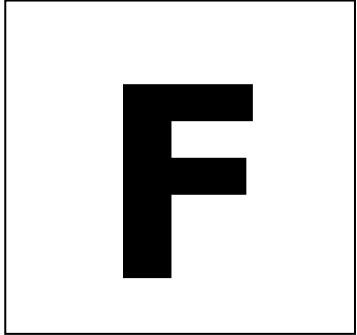

**ST MARY'S SCIENCE
DEPARTMENT:
PHYSICS**



**GCSE PHYSICS HOMEWORK BOOK
TOPIC 2: CIRCUIT ELECTRICITY
STUDENT BOOK**

YOU MUST ANSWER ALL THREE SECTIONS IN EACH PART OF THE HOMEWORK TASKS

NAME	
CLASS	
TEACHER	
FORM	

TASK	MARK	GRADE
1		
2		
3		
4		
5		
OVERALL		

**GCSE
PHYSICS
YEAR 9
TOPIC 2**

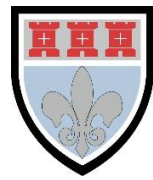

HOMEWORK SCHEDULE

Please use the following table to ensure each homework task is completed and submitted on time.

Carrying out these homework tasks can only increase your ability to gain a high grade in the GCSE examinations.

Failure to hand in work on time will lead to sanctions to complete this work.

Task	Submission Date	Completed?	On Time?
Task 1 Introduction to Electricity			
Task 2 Current and Potential Difference			
Task 3 Resistance			
Task 4 Resistance in Series and Parallel			
Task 5 I-V Characteristics			



SCIENCE DEPARTMENT MARKING CODE

ID = Insufficient detail in answer

W = Wrong understanding of science.

IR = Irrelevant information given.

V = This is too vague to get a mark.

AQ = Answer the question asked

R = Read the question/information

M = Maths mistake

BOD = Benefit of the doubt given.

E = Explain the answer further please.

U = Wrong units used.

SF = Wrong significant figures used.

SP = Wrong spelling of a technical term

SR = Same reason given twice.

A circle means this lost you marks

An underline means this gained you marks

IMPORTANT NOTE

All sections in each task must be **FULLY ATTEMPTED**.

If students fail to achieve an acceptable mark on each task, they will be made to carry out supervised intervention the following week.

Each week, intervention sessions will be provided to help assist with answering the questions in the homework booklet if students are struggling with the difficulty of the problems.



PLEASE READ

This homework booklet has made with custom selected examination questions and activities to assess your understanding in the concepts covered in class. This will increase your familiarity with the style of examination questions.

Carrying out these questions can only increase your ability to gain a high grade in the GCSE examination.







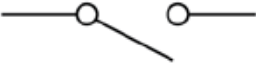

Thank you for your hard work in completing this book, and good luck.

Mr. Turnbull

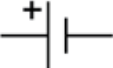
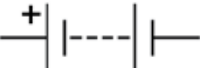

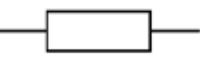
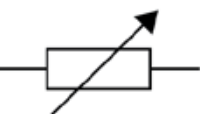
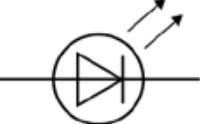
TASK 1: INTRODUCTION TO ELECTRICITY

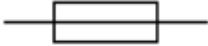
SPEC CHECK

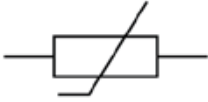
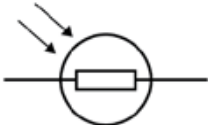
Content	Achieved?
Circuit diagrams use standard symbols.	
 switch (open)	
 switch (closed)	
 cell	
 battery	
 diode	
 resistor	
 variable resistor	
 LED	
 lamp	
 fuse	
 voltmeter	
 ammeter	
 thermistor	
 LDR	
<p>Students should be able to draw and interpret circuit diagrams.</p>	

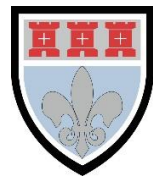
**SECTION A**

This is a revision question on a previous topic.

You should aim to spend **10 minutes** answering this section.

By looking at the attached pictures, answer the following multiple choice questions.

A1. What component is represented by the following symbol?



Tick only **one** answer.

- A. Bulb
- B. Cell
- C. Switch
- D. Voltmeter

A2. What component is represented by the following symbol?

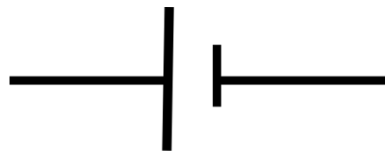

Tick only **one** answer.

- A. Bulb
- B. Cell
- C. Switch
- D. Voltmeter

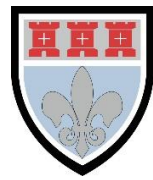

A3. What component is represented by the following symbol?

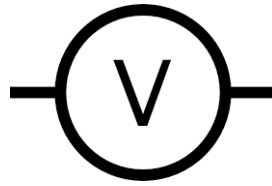

Tick only **one** answer.

- A. Bulb
- B. Cell
- C. Switch
- D. Voltmeter

A4. What component is represented by the following symbol?

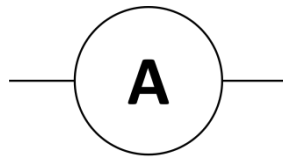

Tick only **one** answer.

- A. Bulb
- B. Ammeter
- C. Motor
- D. Voltmeter

A5. What component is represented by the following symbol?



Tick only **one** answer.

- A. Thermistor
- B. Resistor
- C. Switch
-



SECTION B

This is a question to revise understanding carried out in lesson.

You should aim to spend **10 minutes** answering this section.

1. Figure 18 shows identical filament lamps connected together to a 12 V power supply.

Figure 18

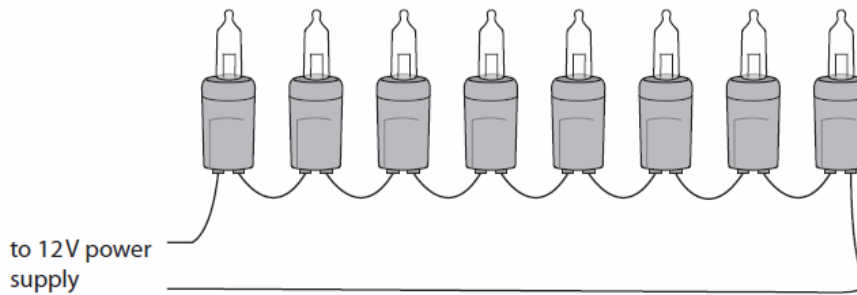

1.1 Calculate the potential difference across each lamp.

[1 Mark]

.....

.....

.....

.....

Potential Difference = V

1.2 The power output of each lamp is 0.75 W

Calculate the resistance of each lamp.

[4 Marks]

.....

.....

.....

.....

.....

.....

Resistance = Ω

**SECTION C**

This is a revision question to consolidate your understanding.

You should aim to spend **10 minutes** answering this section.

1. Figure 2 shows how the current through a filament lamp changes after the lamp is switched on.

Figure 2

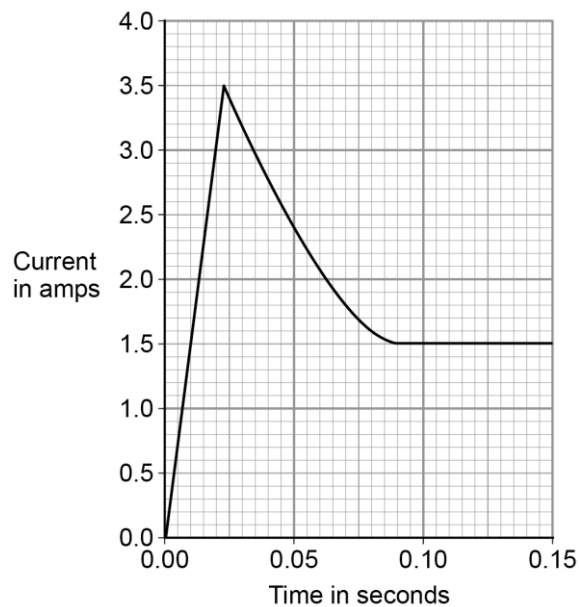

1.1 The normal current through the filament lamp is 1.5 A.

For how many seconds is the current through the filament lamp greater than 1.5 A?

Tick **one** box.

[1 mark]

- 0.01 s
- 0.08 s
- 0.09 s
- 0.14 s



1.2 Why might the filament inside a lamp melt when the lamp is first switched on?

[1 mark]

.....
.....

1.3 The lamp is connected to a 24 V power supply. The current through the lamp is 1.5 A.

Calculate the power of the lamp.

Use the equation:

$$\text{power} = \text{potential difference} \times \text{current}$$

[2 marks]

.....
.....
.....
.....

Power = W

1.4 LED lamps are much more efficient than filament lamps.

What does this statement mean?

Tick **one** box.

[1 mark]

LED lamps have a similar power output to filament lamps.

LED lamps waste a smaller proportion of the input energy than filament lamps.

LED lamps have a higher power input than filament lamps.

LED lamps waste a larger proportion of the input energy than filament lamps.



FEEDBACK SHEET

Overall Mark:	/21	GRADE ACHIEVED:
Section A :	/5	5 <input type="checkbox"/> 1 <input type="checkbox"/>
Section B :	/11	4 <input type="checkbox"/> U <input type="checkbox"/>
Section C :	/5	3 <input type="checkbox"/>
		2 <input type="checkbox"/>

Knowledge and understanding shown	Unsatisfactory	Satisfactory	Good	Outstanding
Strengths:	<input type="checkbox"/> Basic Knowledge of Concepts <input type="checkbox"/> Applications of Concepts <input type="checkbox"/> Quality of Written Communication <input type="checkbox"/> Mathematical Skills <input type="checkbox"/> Working Scientifically <input type="checkbox"/> Experimental Technique <input type="checkbox"/> Answering Examination Questions <input type="checkbox"/> Previous Topics <input type="checkbox"/> Analytical Skills <input type="checkbox"/> Problem Solving Others (Topic Specific)			
Areas to Improve:	<input type="checkbox"/> Basic Knowledge of Concepts <input type="checkbox"/> Applications of Concepts <input type="checkbox"/> Quality of Written Communication <input type="checkbox"/> Mathematical Skills <input type="checkbox"/> Working Scientifically <input type="checkbox"/> Experimental Technique <input type="checkbox"/> Answering Examination Questions <input type="checkbox"/> Previous Topics <input type="checkbox"/> Analytical Skills <input type="checkbox"/> Problem Solving Others (Topic Specific)			
Progress:	Unsatisfactory	Satisfactory	Good	Outstanding
Working:	Below	In line with	Above	(your target)
Effort:	Poor	Inconsistent	Good	Excellent

To improve further you need to:

- | | |
|--|--|
| <ul style="list-style-type: none"> <input type="checkbox"/> Carry out independent revision. <input type="checkbox"/> Complete outstanding work. <input type="checkbox"/> Make corrections as indicated by the teacher. <input type="checkbox"/> Attend intervention for this topic <input type="checkbox"/> Include more information in responses. <input type="checkbox"/> Include more key words in responses. <input type="checkbox"/> Attend departmental revision sessions. <input type="checkbox"/> Read the questions carefully. <input type="checkbox"/> Explain your answers in more detail. <input type="checkbox"/> Carry out revision on Seneca Learning. | <ul style="list-style-type: none"> <input type="checkbox"/> Revise the equations. <input type="checkbox"/> Check the units on answers. <input type="checkbox"/> Check the correct amount of sig figs on answers. <input type="checkbox"/> Check to convert values correctly. <input type="checkbox"/> Show your full working out. <input type="checkbox"/> Check your calculations. <input type="checkbox"/> Revise the science investigative skills. <input type="checkbox"/> Revise the key concepts of the topics. <input type="checkbox"/> Thoroughly check your work for mistakes. <p>Other:</p> |
|--|--|

Student response



TASK 2: CURRENT AND POTENTIAL DIFFERENCE

SPEC CHECK

Content	Achieved?
<p>The current (I) through a component depends on both the resistance (R) of the component and the potential difference (V) across the component.</p> <p>The greater the resistance of the component the smaller the current for a given potential difference (pd) across the component.</p> <p>Questions will be set using the term potential difference.</p> <p>Current, potential difference or resistance can be calculated using the equation: potential difference = current \times resistance $V = I R$ potential difference, V, in volts, V, current, I, in amperes, A (amp is acceptable for ampere) resistance, R, in ohms, Ω.</p> <p>Students should be able to recall and apply this equation.</p>	

Target Setting

In this assessed piece of work, what target should I look to achieve in completing this task?
 Please refer to your marking feedback for your target.

From your previous work, fill in the following boxes with your personal progress in Physics.

What Topics Do I Know Well?

What Topics Do I Need to Revise?

**SECTION A**

This is a revision question on a previous topic.

You should aim to spend **10 minutes** answering this section.

Answer the following questions...

A1. What causes charge to flow in a circuit?

Tick only **one** answer.

- A. Potential Difference
- B. Current
- C. Nothing can.
- D. Power

A2. What is the name of the rate of flow of charge in a circuit?

Tick only **one** answer.

- A. Potential Difference
- B. Current
- C. Charge Moving
- D. Power

A3. What is the unit of charge?

Tick only **one** answer.

- A. Coulombs
- B. Amps
- C. Volts
- D. Watts



A4. What is the unit of potential difference?

Tick only **one** answer.

- A. Coulombs
- B. Amps
- C. Volts
- D. Watts

A5. What is the unit of current?

Tick only **one** answer.

- A. Coulombs
- B. Amps
- C. Volts
- D. Watts



SECTION B

This is a question to revise understanding carried out in lesson.

You should aim to spend **10 minutes** answering this section.

1. An electrical circuit is shown in the figure below.

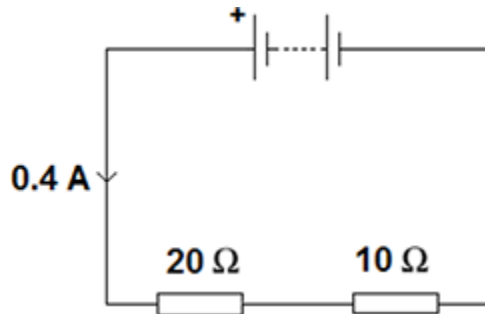

1.1 The current in the circuit is direct current.

What is meant by direct current?

[1 mark]

Tick **one** box.

Current that continuously changes direction.

Current that travels directly to the component.

Current that is always in the same direction.

1.2 The equation which links current, potential difference and resistance is:

potential difference = current × resistance

Calculate the potential difference across the battery in the circuit in the figure above.

[3 marks]

.....

.....

.....

.....

Potential difference = _____ V

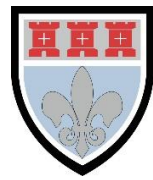

1.3 The equation which links current, potential difference and power is:

$$\text{power} = \text{current} \times \text{potential difference}$$

Calculate the power output of the battery in the figure above.

Give your answer to **one** significant figure.

[2 marks]

.....

.....

.....

.....

Power = _____ W



SECTION C

This is a revision question to consolidate your understanding.

You should aim to spend **10 minutes** answering this section.

1. **Figure 9** shows a circuit diagram.

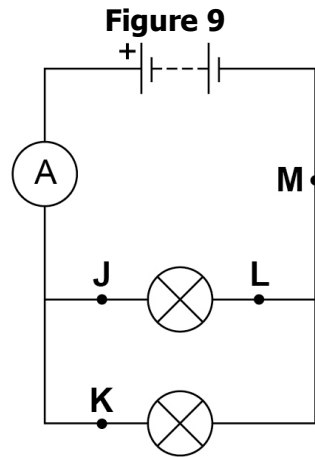

1.1 In which position could a switch be placed so that both lamps can be switched on or off at the same time?

[1 mark]

Tick **one** box.

J	<input type="checkbox"/>	K	<input type="checkbox"/>	L	<input type="checkbox"/>	M	<input type="checkbox"/>
---	--------------------------	---	--------------------------	---	--------------------------	---	--------------------------

1.2 Draw the circuit symbol for a switch in the box below.

[1 mark]



1.3 In 30 seconds, 24 coulombs of charge flow through the battery.
Calculate the current in the battery.
Use the equation:

$$\text{current} = \frac{\text{charge flow}}{\text{time}}$$

[2 marks]

.....

.....

.....

.....

.....

.....

Current = A

1.4 There is a potential difference of 3.6 V across the battery.
Calculate the energy transferred by the battery when 60 coulombs of charge flows through the battery.
Use the equation:

$$\text{energy transferred} = \text{charge flow} \times \text{potential difference}$$

[2 marks]

.....

.....

.....

.....

.....

.....

Energy Transferred = J



FEEDBACK SHEET

Overall Mark:	/17	GRADE ACHIEVED:	
Section A :	/5	5 <input type="checkbox"/>	1 <input type="checkbox"/>
Section B :	/6	4 <input type="checkbox"/>	U <input type="checkbox"/>
Section C :	/6	3 <input type="checkbox"/>	
		2 <input type="checkbox"/>	

Knowledge and understanding shown	Unsatisfactory	Satisfactory	Good	Outstanding		
Strengths:	<table style="width: 100%; border: none;"> <tr> <td style="width: 50%; border: none;"> <input type="checkbox"/> Basic Knowledge of Concepts <input type="checkbox"/> Quality of Written Communication <input type="checkbox"/> Working Scientifically <input type="checkbox"/> Answering Examination Questions <input type="checkbox"/> Analytical Skills Others (Topic Specific) </td> <td style="width: 50%; border: none;"> <input type="checkbox"/> Applications of Concepts <input type="checkbox"/> Mathematical Skills <input type="checkbox"/> Experimental Technique <input type="checkbox"/> Previous Topics <input type="checkbox"/> Problem Solving </td> </tr> </table>				<input type="checkbox"/> Basic Knowledge of Concepts <input type="checkbox"/> Quality of Written Communication <input type="checkbox"/> Working Scientifically <input type="checkbox"/> Answering Examination Questions <input type="checkbox"/> Analytical Skills Others (Topic Specific)	<input type="checkbox"/> Applications of Concepts <input type="checkbox"/> Mathematical Skills <input type="checkbox"/> Experimental Technique <input type="checkbox"/> Previous Topics <input type="checkbox"/> Problem Solving
<input type="checkbox"/> Basic Knowledge of Concepts <input type="checkbox"/> Quality of Written Communication <input type="checkbox"/> Working Scientifically <input type="checkbox"/> Answering Examination Questions <input type="checkbox"/> Analytical Skills Others (Topic Specific)	<input type="checkbox"/> Applications of Concepts <input type="checkbox"/> Mathematical Skills <input type="checkbox"/> Experimental Technique <input type="checkbox"/> Previous Topics <input type="checkbox"/> Problem Solving					
Areas to Improve:	<table style="width: 100%; border: none;"> <tr> <td style="width: 50%; border: none;"> <input type="checkbox"/> Basic Knowledge of Concepts <input type="checkbox"/> Quality of Written Communication <input type="checkbox"/> Working Scientifically <input type="checkbox"/> Answering Examination Questions <input type="checkbox"/> Analytical Skills Others (Topic Specific) </td> <td style="width: 50%; border: none;"> <input type="checkbox"/> Applications of Concepts <input type="checkbox"/> Mathematical Skills <input type="checkbox"/> Experimental Technique <input type="checkbox"/> Previous Topics <input type="checkbox"/> Problem Solving </td> </tr> </table>				<input type="checkbox"/> Basic Knowledge of Concepts <input type="checkbox"/> Quality of Written Communication <input type="checkbox"/> Working Scientifically <input type="checkbox"/> Answering Examination Questions <input type="checkbox"/> Analytical Skills Others (Topic Specific)	<input type="checkbox"/> Applications of Concepts <input type="checkbox"/> Mathematical Skills <input type="checkbox"/> Experimental Technique <input type="checkbox"/> Previous Topics <input type="checkbox"/> Problem Solving
<input type="checkbox"/> Basic Knowledge of Concepts <input type="checkbox"/> Quality of Written Communication <input type="checkbox"/> Working Scientifically <input type="checkbox"/> Answering Examination Questions <input type="checkbox"/> Analytical Skills Others (Topic Specific)	<input type="checkbox"/> Applications of Concepts <input type="checkbox"/> Mathematical Skills <input type="checkbox"/> Experimental Technique <input type="checkbox"/> Previous Topics <input type="checkbox"/> Problem Solving					
Progress:	Unsatisfactory	Satisfactory	Good	Outstanding		
Working:	Below	In line with	Above	(your target)		
Effort:	Poor	Inconsistent	Good	Excellent		

To improve further you need to:

- | | |
|--|--|
| <ul style="list-style-type: none"> <input type="checkbox"/> Carry out independent revision. <input type="checkbox"/> Complete outstanding work. <input type="checkbox"/> Make corrections as indicated by the teacher. <input type="checkbox"/> Attend intervention for this topic <input type="checkbox"/> Include more information in responses. <input type="checkbox"/> Include more key words in responses. <input type="checkbox"/> Attend departmental revision sessions. <input type="checkbox"/> Read the questions carefully. <input type="checkbox"/> Explain your answers in more detail. <input type="checkbox"/> Carry out revision on Seneca Learning. | <ul style="list-style-type: none"> <input type="checkbox"/> Revise the equations. <input type="checkbox"/> Check the units on answers. <input type="checkbox"/> Check the correct amount of sig figs on answers. <input type="checkbox"/> Check to convert values correctly. <input type="checkbox"/> Show your full working out. <input type="checkbox"/> Check your calculations. <input type="checkbox"/> Revise the science investigative skills. <input type="checkbox"/> Revise the key concepts of the topics. <input type="checkbox"/> Thoroughly check your work for mistakes. <p>Other:</p> |
|--|--|

Student response

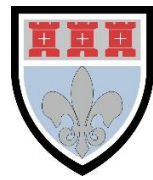
**TASK 3: RESISTANCE****SPEC CHECK**

Content	Achieved?
Use circuit diagrams to set up and check appropriate circuits to investigate the factors affecting the resistance of electrical circuits. This should include: The length of a wire at constant temperature.	

Target Setting

In this assessed piece of work, what target should I look to achieve in completing this task?
Please refer to your marking feedback for your target.

From your previous work, fill in the following boxes with your personal progress in Physics.

What Topics Do I Know Well?

What Topics Do I Need to Revise?



SECTION A

This is a revision question on a previous topic.

You should aim to spend **10 minutes** answering this section.

Answer the following questions based on the case study below.

Hypothesis: The energy stored in a battery depends on the mass of the battery.

Case Study A

Mass of battery (g)	Energy Stored (kJ)
10	43
20	86
30	129
40	172
50	215

Case Study B

Mass of battery (g)	How long it will power a torch (minutes)
10	11.9
20	23.9
30	35.8
40	47.8
50	59.7

Case Study C

Name of battery	Voltage (V)		
	Trial 1	Trial 2	Trial 3
Alkaline	1.50	1.80	1.50
Ni-Cd	1.25	1.55	1.25
Ni-M-H	1.20	1.50	1.20
Ni-Zn	1.65	1.95	1.65
Zn-C	1.50	1.80	1.50

A1. What is the independent variable in case study A?

Tick only **one** answer.

- A. Mass of Battery
- B. (g)
- C. Energy Stored
- D. (kJ)

A2. What is the interval of the mass of the battery in case study B?

Tick only **one** answer.

- A. 0g
- B. 10g
- C. 20g
- D. 50g

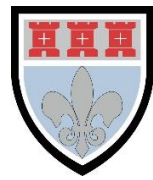

A3. What is the range of the mass of the battery in case study B?

Tick only **one** answer.

- A. 0g
- B. 10g – 50g
- C. 40g
- D. 50g

A4. In case study C, which set of trials is anomalous?

Tick only **one** answer.

- A. Trial 1
- B. Trial 2
- C. Trial 3
- D. There are no anomalies

A5. Which case study directly answers the hypothesis?

Tick only **one** answer.

- A. Case Study A
- B. Case Study B
- C. Case Study C
- D. None do



SECTION B

This is a question to revise understanding carried out in lesson.

You should aim to spend **10 minutes** answering this section.

1. A resistor is a component that is used in an electric circuit.

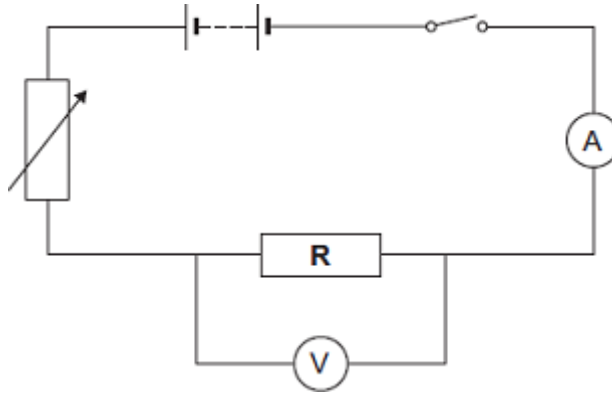

1.1 Describe how a student would use the circuit to take the readings necessary to determine the resistance of resistor **R**.

[6 marks]

.....

.....

.....

.....

.....

.....

.....

.....

.....

.....

.....

.....

.....

.....

.....

.....

.....

.....

.....

.....

.....

.....

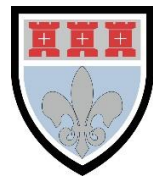

1.2 Explain why the student should open the switch after each reading.

[2 marks]

.....

.....

.....

.....

1.3 In an experiment using this circuit, an ammeter reading was 0.75 A.
The calculated value of the resistance of resistor **R** was 16 Ω .

What is the voltmeter reading?

[2 marks]

.....

.....

.....

Voltmeter Reading = _____ V

1.4 The student told his teacher that the resistance of resistor **R** was 16 Ω .

The teacher explained that the resistors used could only have one of the following values of resistance.

10 Ω 12 Ω 15 Ω 18 Ω 22 Ω

Suggest which of these resistors the student had used in his experiment.

Give a reason for your answer.

[2 marks]

.....

.....

.....

.....

.....

.....



SECTION C

This is a revision question to consolidate your understanding.

You should aim to spend **10 minutes** answering this section.

1.1 Draw **one** line from each circuit symbol to its correct name.

[3 marks]

Circuit symbol	Name
	Diode
	Light-dependent resistor (LDR)
	Lamp
	Light-emitting diode (LED)

Figure 1 shows three circuits.

The resistors in the circuits are identical.

Each of the cells has a potential difference of 1.5 volts.

Figure 1

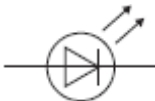
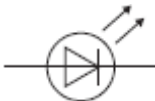
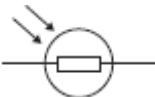
Circuit 1

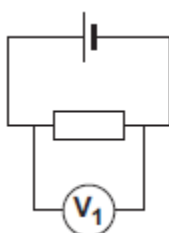

Circuit 2

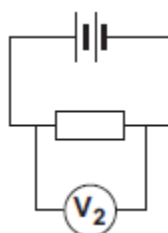

Circuit 3

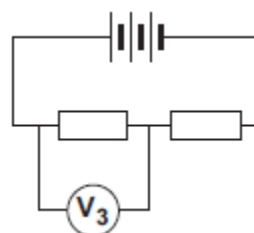



1.2 Use the correct answer from the box to complete the sentence.

half twice the same as

[1 mark]

The resistance of **circuit 1** is _____ the resistance of **circuit 3**.

1.3 Calculate the reading on voltmeter **V₂**.

[1 mark]

.....

Voltmeter reading **V₂** = _____ V

1.4 Which voltmeter, **V₁**, **V₂** or **V₃**, will give the lowest reading?

Draw a ring around the correct answer.

V₁ V₂ V₃

[1 mark]

A student wanted to find out how the number of resistors affects the current in a series circuit.

Figure 2 shows the circuit used by the student.

Figure 2



The student started with one resistor and then added more identical resistors to the circuit.

Each time a resistor was added, the student closed the switch and took the ammeter reading.

The student used a total of 4 resistors.



Figure 3 shows three of the results obtained by the student.

Figure 3

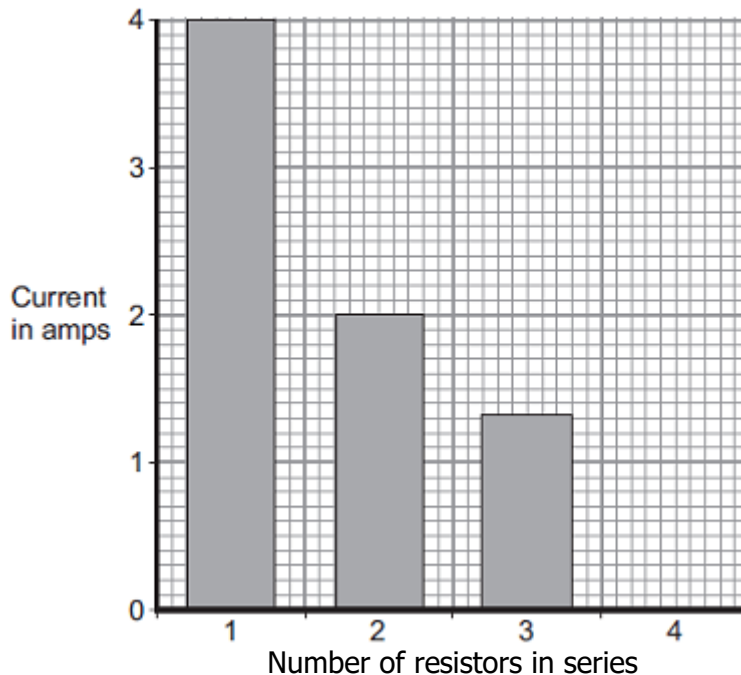

1.5 To get valid results, the student kept one variable the same throughout the experiment.

Which variable did the student keep the same?

[1 mark]

.....

.....

1.6 The bar chart in **Figure 3** is not complete. The result using 4 resistors is not shown.

Complete the bar chart to show the current in the circuit when 4 resistors were used.

[2 marks]

1.7 What conclusion should the student make from the bar chart?

[1 mark]

.....

.....



FEEDBACK SHEET

Overall Mark:	/27	GRADE ACHIEVED:
Section A :	/5	5 <input type="checkbox"/> 1 <input type="checkbox"/>
Section B :	/12	4 <input type="checkbox"/> U <input type="checkbox"/>
Section C :	/10	3 <input type="checkbox"/>
		2 <input type="checkbox"/>

Knowledge and understanding shown	Unsatisfactory	Satisfactory	Good	Outstanding
Strengths:	<input type="checkbox"/> Basic Knowledge of Concepts <input type="checkbox"/> Applications of Concepts <input type="checkbox"/> Quality of Written Communication <input type="checkbox"/> Mathematical Skills <input type="checkbox"/> Working Scientifically <input type="checkbox"/> Experimental Technique <input type="checkbox"/> Answering Examination Questions <input type="checkbox"/> Previous Topics <input type="checkbox"/> Analytical Skills <input type="checkbox"/> Problem Solving Others (Topic Specific)			
Areas to Improve:	<input type="checkbox"/> Basic Knowledge of Concepts <input type="checkbox"/> Applications of Concepts <input type="checkbox"/> Quality of Written Communication <input type="checkbox"/> Mathematical Skills <input type="checkbox"/> Working Scientifically <input type="checkbox"/> Experimental Technique <input type="checkbox"/> Answering Examination Questions <input type="checkbox"/> Previous Topics <input type="checkbox"/> Analytical Skills <input type="checkbox"/> Problem Solving Others (Topic Specific)			
Progress:	Unsatisfactory	Satisfactory	Good	Outstanding
Working:	Below	In line with	Above	(your target)
Effort:	Poor	Inconsistent	Good	Excellent

To improve further you need to:

- | | |
|--|--|
| <ul style="list-style-type: none"> <input type="checkbox"/> Carry out independent revision. <input type="checkbox"/> Complete outstanding work. <input type="checkbox"/> Make corrections as indicated by the teacher. <input type="checkbox"/> Attend intervention for this topic <input type="checkbox"/> Include more information in responses. <input type="checkbox"/> Include more key words in responses. <input type="checkbox"/> Attend departmental revision sessions. <input type="checkbox"/> Read the questions carefully. <input type="checkbox"/> Explain your answers in more detail. <input type="checkbox"/> Carry out revision on Seneca Learning. | <ul style="list-style-type: none"> <input type="checkbox"/> Revise the equations. <input type="checkbox"/> Check the units on answers. <input type="checkbox"/> Check the correct amount of sig figs on answers. <input type="checkbox"/> Check to convert values correctly. <input type="checkbox"/> Show your full working out. <input type="checkbox"/> Check your calculations. <input type="checkbox"/> Revise the science investigative skills. <input type="checkbox"/> Revise the key concepts of the topics. <input type="checkbox"/> Thoroughly check your work for mistakes. <p>Other:</p> |
|--|--|

Student response

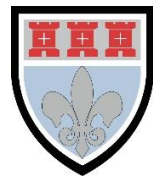
**TASK 4: RESISTANCE IN SERIES AND PARALLEL****SPEC CHECK**

Content	Achieved?
Use circuit diagrams to set up and check appropriate circuits to investigate the factors affecting the resistance of electrical circuits. This should include: Combinations of resistors in series and parallel.	

Target Setting

In this assessed piece of work, what target should I look to achieve in completing this task?
Please refer to your marking feedback for your target.

From your previous work, fill in the following boxes with your personal progress in Physics.

What Topics Do I Know Well?

What Topics Do I Need to Revise?

**SECTION A**

This is a revision question on a previous topic.

You should aim to spend **10 minutes** answering this section.

You have a resistor in a circuit.

A1. What effect, if any, will placing another resistor in series with the original resistors have on the total circuit resistance?

Tick only **one** answer.

- A. No effect.
- B. There will be no resistance.
- C. The resistance will increase.
- D. The resistance will decrease.

A2. What effect, if any, will placing another resistor in parallel with the original resistor have on the total circuit resistance?

Tick only **one** answer.

- A. No effect.
- B. There will be no resistance.
- C. The resistance will increase.
- D. The resistance will decrease.

You carry out an investigation to measure the resistance of a wire.

A3. To do this, you measure the potential difference across the wire. What device is used to do this?

Tick only **one** answer.

- A. Voltmeter
- B. Power pack.
- C. Ammeter
- D. Bulb

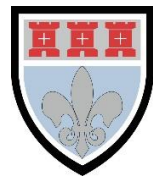

A4. How is the device mentioned in A3 placed in the electrical circuit?

Tick only **one** answer.

- A. In series.
- B. In parallel with the wire.
- C. In parallel with the battery.
- D. It is not attached to anything.

A5. In between taking measurements you turn off the powerpack. Why?

Tick only **one** answer.

- A. To save electricity.
- B. To make the experiment safe.
- C. To make sure the resistance does not change.
- D. To not lose any volts in the circuit.



SECTION B

This is a question to revise understanding carried out in lesson.

You should aim to spend **10 minutes** answering this section.

1. Figure 7 shows a circuit with two resistors **X** and **Y** in parallel.

Figure 7

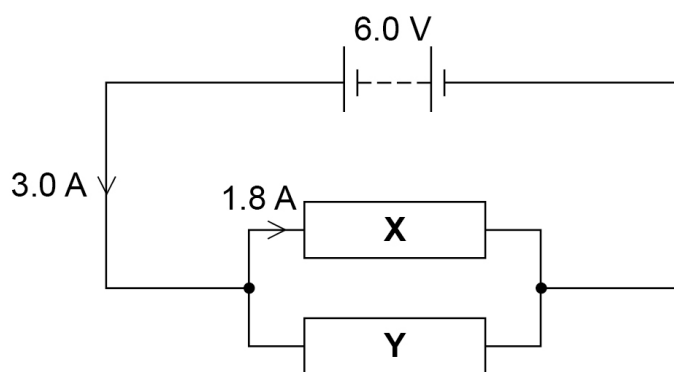

1.1 Determine the current in resistor **Y**.

[1 mark]

Current = A

1.2 Give the potential difference across resistor **Y**.

[1 mark]

Potential Difference = V

1.3 Calculate the resistance of resistor **Y**.

Use the Physics Equations Sheet.

[2 marks]

Resistance = Ω

1.4 Resistor **X** and resistor **Y** are then connected in series. **Figure 8** shows the series circuit.

Figure 8

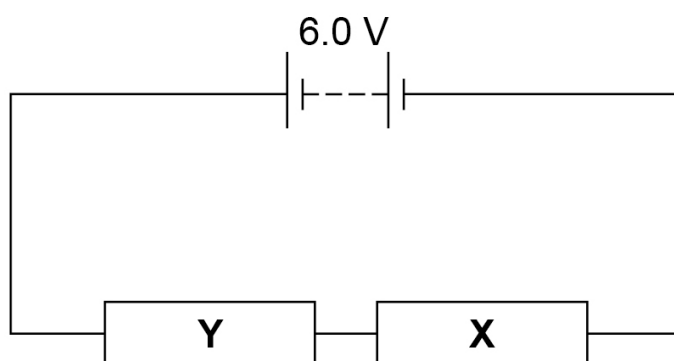



Complete **Table 3** to explain what happens when the resistors are connected in series rather than in parallel.

[5 marks]

Table 3

	Change	Reason
Resistance of circuit	Increases	
Current in circuit		
Potential difference across Y		



SECTION C

This is a revision question to consolidate your understanding.

You should aim to spend **10 minutes** answering this section.

1. Draw a diagram to show how 1.5 V cells should be connected together to give a potential difference of 4.5 V.

Use the correct circuit symbol for a cell.

[2 marks]

A student built the circuit shown in **Figure 3**.

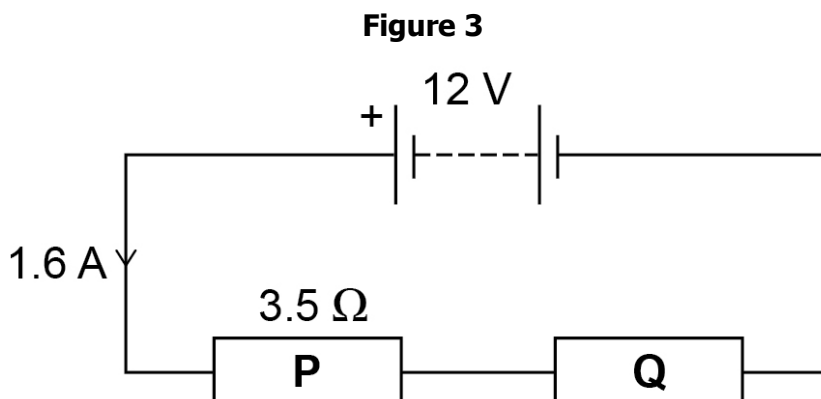

1.2 Calculate the total resistance of the circuit in **Figure 3**.

Use the equation:

$$\text{resistance} = \frac{\text{potential difference}}{\text{current}}$$

[2 marks]

.....

.....

.....

.....

Total Resistance = Ω

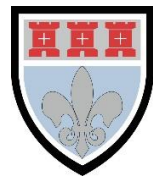

1.3 The resistance of P is 3.5Ω .

Calculate the resistance of **Q**.

[1 mark]

.....

.....

.....

.....

Resistance of **Q** = Ω

1.4 The student connects the two resistors in **Figure 3** in parallel.

What happens to the total resistance of the circuit?

Tick **one** box.

[1 mark]

It decreases

It increases

It does not change

Give a reason for your answer.

[1 mark]

.....

.....

.....

.....



FEEDBACK SHEET

Overall Mark:	/21	GRADE ACHIEVED:
Section A:	/5	5 <input type="checkbox"/> 1 <input type="checkbox"/>
Section B :	/9	4 <input type="checkbox"/> U <input type="checkbox"/>
Section C:	/7	3 <input type="checkbox"/>
		2 <input type="checkbox"/>

Knowledge and understanding shown	Unsatisfactory	Satisfactory	Good	Outstanding
Strengths:	<input type="checkbox"/> Basic Knowledge of Concepts <input type="checkbox"/> Applications of Concepts <input type="checkbox"/> Quality of Written Communication <input type="checkbox"/> Mathematical Skills <input type="checkbox"/> Working Scientifically <input type="checkbox"/> Experimental Technique <input type="checkbox"/> Answering Examination Questions <input type="checkbox"/> Previous Topics <input type="checkbox"/> Analytical Skills <input type="checkbox"/> Problem Solving Others (Topic Specific)			
Areas to Improve:	<input type="checkbox"/> Basic Knowledge of Concepts <input type="checkbox"/> Applications of Concepts <input type="checkbox"/> Quality of Written Communication <input type="checkbox"/> Mathematical Skills <input type="checkbox"/> Working Scientifically <input type="checkbox"/> Experimental Technique <input type="checkbox"/> Answering Examination Questions <input type="checkbox"/> Previous Topics <input type="checkbox"/> Analytical Skills <input type="checkbox"/> Problem Solving Others (Topic Specific)			
Progress:	Unsatisfactory	Satisfactory	Good	Outstanding
Working:	Below	In line with	Above	(your target)
Effort:	Poor	Inconsistent	Good	Excellent

To improve further you need to:

- | | |
|--|--|
| <ul style="list-style-type: none"> <input type="checkbox"/> Carry out independent revision. <input type="checkbox"/> Complete outstanding work. <input type="checkbox"/> Make corrections as indicated by the teacher. <input type="checkbox"/> Attend intervention for this topic <input type="checkbox"/> Include more information in responses. <input type="checkbox"/> Include more key words in responses. <input type="checkbox"/> Attend departmental revision sessions. <input type="checkbox"/> Read the questions carefully. <input type="checkbox"/> Explain your answers in more detail. <input type="checkbox"/> Carry out revision on Seneca Learning. | <ul style="list-style-type: none"> <input type="checkbox"/> Revise the equations. <input type="checkbox"/> Check the units on answers. <input type="checkbox"/> Check the correct amount of sig figs on answers. <input type="checkbox"/> Check to convert values correctly. <input type="checkbox"/> Show your full working out. <input type="checkbox"/> Check your calculations. <input type="checkbox"/> Revise the science investigative skills. <input type="checkbox"/> Revise the key concepts of the topics. <input type="checkbox"/> Thoroughly check your work for mistakes. <p>Other:</p> |
|--|--|

Student response



TASK 5: I-V CHARACTERISTICS

SPEC CHECK

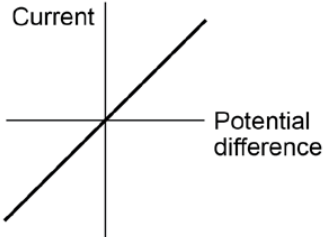
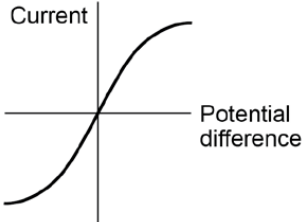
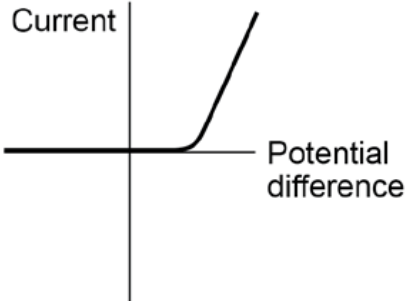
Content	Achieved?
<p>Students should be able to explain that, for some resistors, the value of R remains constant but that in others it can change as the current changes.</p> <p>The current through an ohmic conductor (at a constant temperature) is directly proportional to the potential difference across the resistor. This means that the resistance remains constant as the current changes.</p>  <p>The resistance of components such as lamps, diodes, thermistors and LDRs is not constant; it changes with the current through the component.</p> <p>The resistance of a filament lamp increases as the temperature of the filament increases.</p>  <p>The current through a diode flows in one direction only. The diode has a very high resistance in the reverse direction.</p> 	

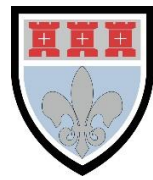

SECTION A

This is a revision question on a previous topic.

You should aim to spend **10 minutes** answering this section.

Answer the following questions based on the following case studies.

Hypothesis: The resistance of a thermistor depends on its temperature.

Case Study A

Temperature (°C)	Resistance of the thermistor (Ω)			
	Trial 1	Trial 2	Trial 3	Mean
20	155	154	157	
30	95	93	95	
40	67	82	68	
50	54	49	50	
60	35	38	36	

Case Study B

Temperature (°C)	Resistance (Ω)
25	130
30	95
35	
40	68
45	60

A1. In case study A, what is the interval of the independent variable?

Tick only **one** answer.

- A. 0°C
- B. 10°C
- C. 20°C
- D. 60°C

A2. In case study A, which temperature reading has an anomalous result?

Tick only **one** answer.

- A. 20°C
- B. 30°C
- C. 40°C
- D. 50°C

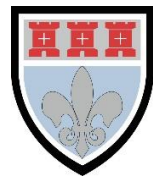

A3. In case study A, to how many decimal places would the mean be calculated to?

Tick only **one** answer.

- A. 0
- B. 1
- C. 2
- D. 3

A4. What does the symbol ' Ω ' represent?

Tick only **one** answer.

- A. Amps
- B. Watts
- C. Ohms
- D. Volts

A5. Which case study could be used to answer the hypothesis?

Tick only **one** answer.

- A. Case Study A
- B. Case Study B
- C. Both
- D. Neither



The student's results are shown in **Figure 1**.

Figure 1

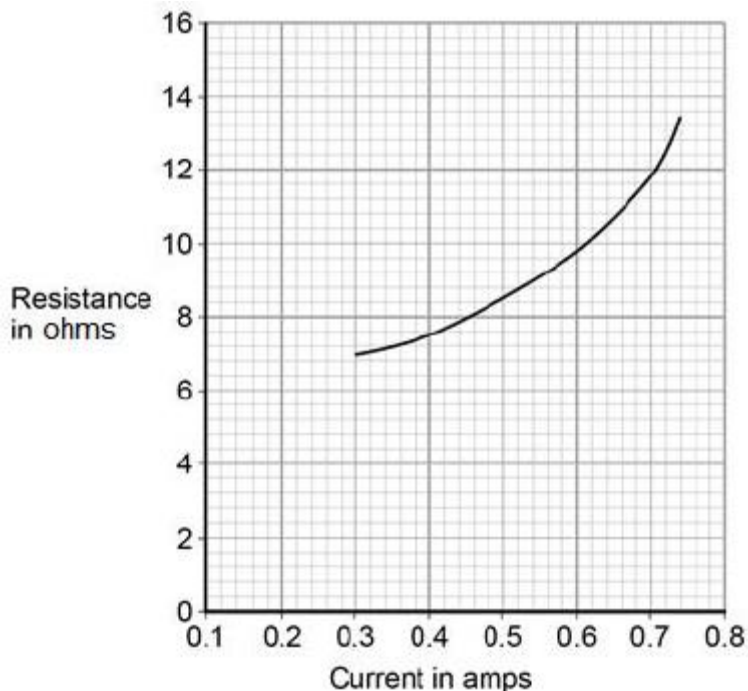

1.3 Describe how the resistance of the filament lamp changes as the current through it increases.

[1 mark]

.....

.....

1.4 Use **Figure 1** to estimate the resistance of the filament lamp when a current of 0.10 A passes through the lamp.

[1 mark]

.....

.....

Resistance = _____ Ω



1.5 The current-potential difference graphs of three components are shown in **Figure 2**.

Use answers from the box to identify each component.

diode	filament lamp	light dependent resistor
resistor at constant temperature		thermistor

[3 Marks]

Figure 2

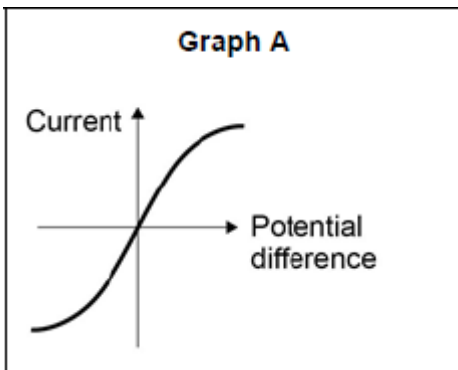

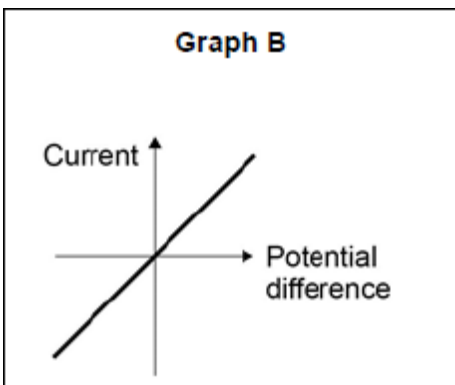

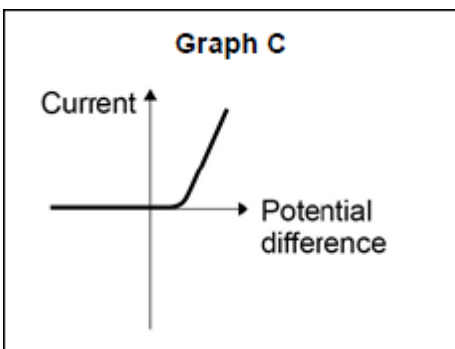



SECTION C

This is a revision question to consolidate your understanding.

You should aim to spend **10 minutes** answering this section.

1.1 A student built Circuit **X** and Circuit **Y** shown in **Figure 10**. The components used in each circuit were identical.

Figure 10

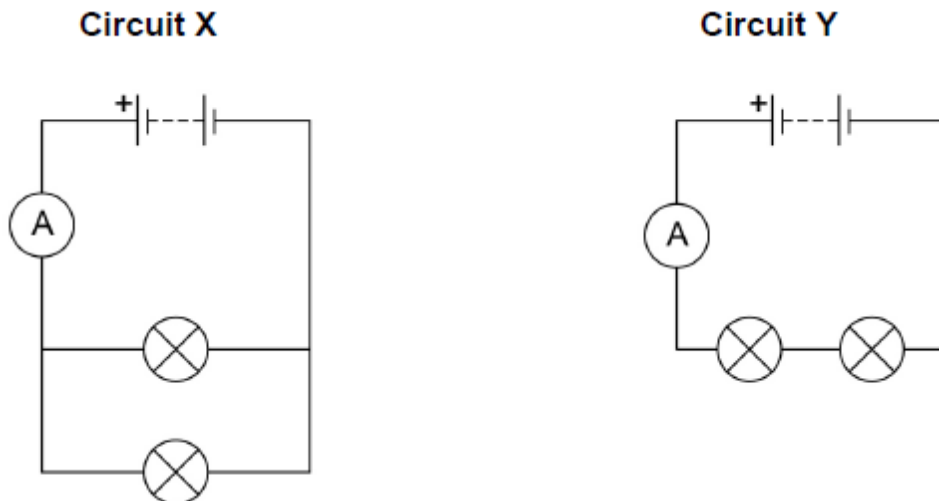

1.1 How would the reading on the ammeter in Circuit **Y** compare to the reading on the ammeter in Circuit **X**?

[1 mark]

Tick **one** box.

The reading in **Y** would be higher.

The reading in **Y** would be lower.

The readings would be the same.

1.2 How does the total resistance of Circuit **Y** compare with the total resistance of Circuit **X**?

[1 mark]

Tick **one** box.

The total resistance of **Y** is greater.

The total resistance of **Y** is less.

The total resistance is the same.



The student built another circuit which is shown in **Figure 11**.

Figure 11

3.6 V

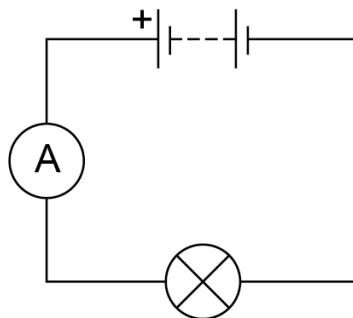

1.3 Write down the equation which links current, potential difference and resistance.

[1 mark]

.....

.....

1.4 There is a potential difference of 3.6 V across the lamp in **Figure 11**.

The current through the lamp is 0.80 A

Calculate the resistance of the lamp.

[3 marks]

.....

.....

.....

.....

.....

.....

Resistance = Ω



FEEDBACK SHEET

Overall Mark:	/22	GRADE ACHIEVED:	
Section A :	/5	5 <input type="checkbox"/>	1 <input type="checkbox"/>
Section B :	/11	4 <input type="checkbox"/>	U <input type="checkbox"/>
Section C :	/6	3 <input type="checkbox"/>	2 <input type="checkbox"/>

Knowledge and understanding shown	Unsatisfactory	Satisfactory	Good	Outstanding
Strengths:	<input type="checkbox"/> Basic Knowledge of Concepts <input type="checkbox"/> Applications of Concepts <input type="checkbox"/> Quality of Written Communication <input type="checkbox"/> Mathematical Skills <input type="checkbox"/> Working Scientifically <input type="checkbox"/> Experimental Technique <input type="checkbox"/> Answering Examination Questions <input type="checkbox"/> Previous Topics <input type="checkbox"/> Analytical Skills <input type="checkbox"/> Problem Solving Others (Topic Specific)			
Areas to Improve:	<input type="checkbox"/> Basic Knowledge of Concepts <input type="checkbox"/> Applications of Concepts <input type="checkbox"/> Quality of Written Communication <input type="checkbox"/> Mathematical Skills <input type="checkbox"/> Working Scientifically <input type="checkbox"/> Experimental Technique <input type="checkbox"/> Answering Examination Questions <input type="checkbox"/> Previous Topics <input type="checkbox"/> Analytical Skills <input type="checkbox"/> Problem Solving Others (Topic Specific)			
Progress:	Unsatisfactory	Satisfactory	Good	Outstanding
Working:	Below	In line with	Above	(your target)
Effort:	Poor	Inconsistent	Good	Excellent

To improve further you need to:

<ul style="list-style-type: none"> <input type="checkbox"/> Carry out independent revision. <input type="checkbox"/> Complete outstanding work. <input type="checkbox"/> Make corrections as indicated by the teacher. <input type="checkbox"/> Attend intervention for this topic <input type="checkbox"/> Include more information in responses. <input type="checkbox"/> Include more key words in responses. <input type="checkbox"/> Attend departmental revision sessions. <input type="checkbox"/> Read the questions carefully. <input type="checkbox"/> Explain your answers in more detail. <input type="checkbox"/> Carry out revision on Seneca Learning. 	<ul style="list-style-type: none"> <input type="checkbox"/> Revise the equations. <input type="checkbox"/> Check the units on answers. <input type="checkbox"/> Check the correct amount of sig figs on answers. <input type="checkbox"/> Check to convert values correctly. <input type="checkbox"/> Show your full working out. <input type="checkbox"/> Check your calculations. <input type="checkbox"/> Revise the science investigative skills. <input type="checkbox"/> Revise the key concepts of the topics. <input type="checkbox"/> Thoroughly check your work for mistakes. <p>Other:</p>
--	--

Student response

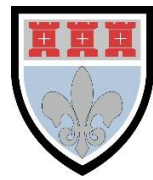

EQUATIONS SHEET



GCSE Physics Equation Sheet

1	pressure due to a column of liquid = height of column × density of liquid × gravitational field strength (g)	$p = h \rho g$
2	(final velocity) ² - (initial velocity) ² = 2 × acceleration × distance	$v^2 - u^2 = 2 a s$
3	force = $\frac{\text{change in momentum}}{\text{time taken}}$	$F = \frac{m \Delta v}{\Delta t}$
4	elastic potential energy = 0.5 × spring constant × (extension) ²	$E_e = \frac{1}{2} k e^2$
5	change in thermal energy = mass × specific heat capacity × temperature change	$\Delta E = m c \Delta \theta$
6	period = $\frac{1}{\text{frequency}}$	
7	magnification = $\frac{\text{image height}}{\text{object height}}$	
8	force on a conductor (at right angles to a magnetic field) carrying a current = magnetic flux density × current × length	$F = B I l$
9	thermal energy for a change of state = mass × specific latent heat	$E = m L$
10	$\frac{\text{potential difference across primary coil}}{\text{potential difference across secondary coil}} = \frac{\text{number of turns in primary coil}}{\text{number of turns in secondary coil}}$	$\frac{V_p}{V_s} = \frac{n_p}{n_s}$
11	potential difference across primary coil × current in primary coil = potential difference across secondary coil × current in secondary coil	$V_s I_s = V_p I_p$
12	For gases: pressure × volume = constant	$p V = \text{constant}$



Acknowledgements

This document has been produced by Mr J Turnbull.

All relevant information has been credited in the document.

This document has been produced for educational purposes only.

This document has been produced for the AQA GCSE Science Specification.

