

Q1.

(a) The diagram shows one pair of nucleotides of a DNA molecule.

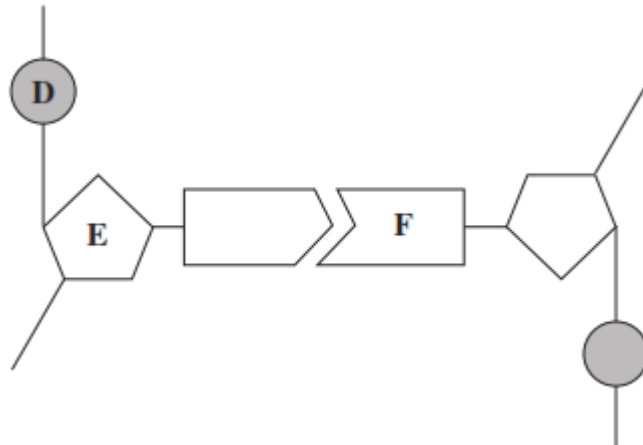

Name _____

D _____

E _____

F _____

(3)

(b) Complete the table to give **two** differences between the structure of DNA and the structure of RNA.

	DNA	RNA
1		
2		

(2)

(Total 5 marks)

Q2.

(a) Complete the table to show **two** differences between the structure of DNA and RNA.

DNA	RNA

(2)

(b) Explain how a gene codes for a protein.

(2)

(c) What are homologous chromosomes?

(2)

(Total 6 marks)

Q3.

The diagram shows one nucleotide pair of a DNA molecule.

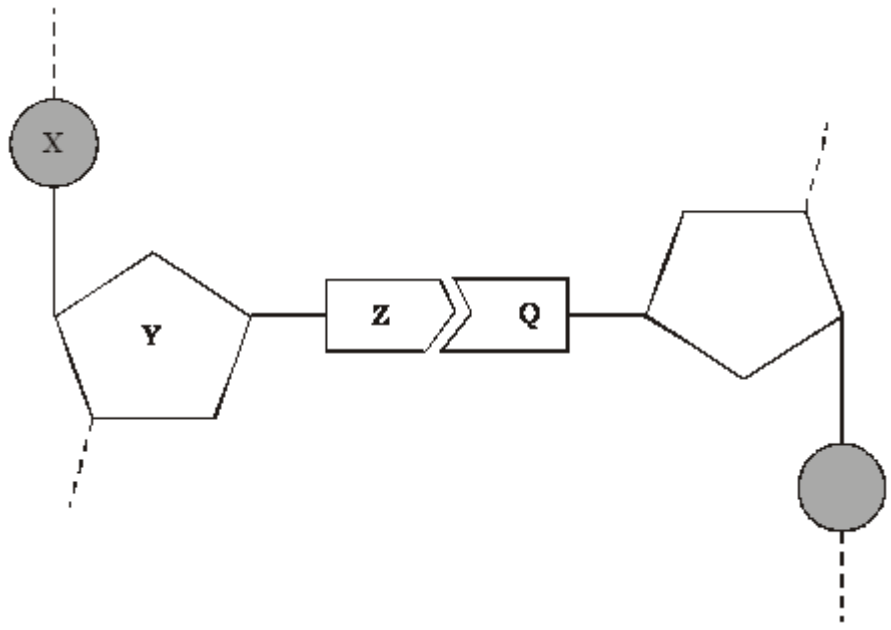

(a) Name the parts of the nucleotide labelled X, Y and Z.

X _____
Y _____
Z _____

(3)

(b) What type of bond holds Z and Q together?

(1)

- (c) A sample of DNA was analysed. 28% of the nucleotides contained thymine. Calculate the percentage of nucleotides which contained cytosine. Show your working.

Answer _____ %

(2)

(Total 6 marks)

Q4.

Figure 1 shows a short section of a DNA molecule.

Figure 1

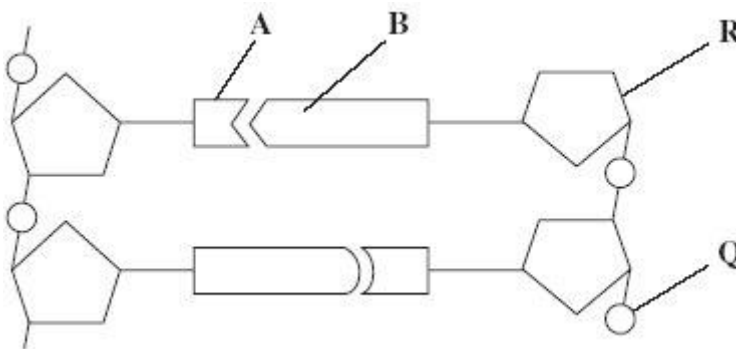

- (a) Name parts **R** and **Q**.

(i) **R** _____

(ii) **Q** _____

(2)

- (b) Name the bonds that join **A** and **B**.

(1)

- (c) Ribonuclease is an enzyme. It is 127 amino acids long.

What is the minimum number of DNA bases needed to code for ribonuclease?

(1)

- (d) **Figure 2** shows the sequence of DNA bases coding for seven amino acids in the enzyme ribonuclease.

Figure 2

G T T T A C T A C T C T T C T T C T T T A

The number of each type of amino acid coded for by this sequence of DNA bases is shown in the table.

Amino acid	Number present
Arg	3
Met	2
Gln	1
Asn	1

Use the table and **Figure 2** to work out the sequence of amino acids in this part of the enzyme. Write your answer in the boxes below.

Gln						
-----	--	--	--	--	--	--

(1)

- (e) Explain how a change in a sequence of DNA bases could result in a non-functional enzyme.

(3)

(Total 8 marks)

Q5.

- (a) Complete the table to show the differences between DNA, mRNA and tRNA.

Type of nucleic acid	Hydrogen bonds present (✓) or not present (✗)	Number of polynucleotide strands in molecule
----------------------	---	--

DNA		
mRNA		
tRNA		

(2)

(b) The diagram shows the bases on one strand of a piece of DNA.

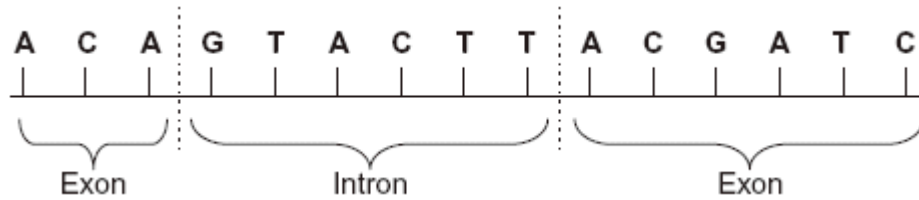

(i) In the space below, give the sequence of bases on the pre-mRNA transcribed from this strand.

(2)

(ii) In the space below, give the sequence of bases on the mRNA produced by splicing this piece of pre-mRNA.

(1)

(Total 5 marks)

Q6.

The diagram shows part of a DNA molecule.

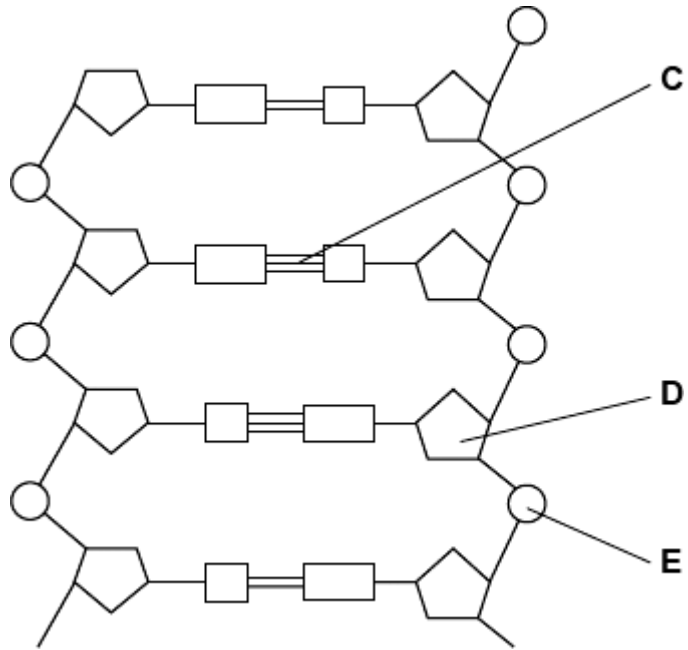

- (a) (i) DNA is a polymer. What is the evidence from the diagram that DNA is a polymer?

(1)

- (ii) Name the parts of the diagram labelled **C**, **D** and **E**.

Part **C** _____

Part **D** _____

Part **E** _____

(3)

- (iii) In a piece of DNA, 34% of the bases were thymine.

Complete the table to show the names and percentages of the other bases.

Name of base	Percentage
Thymine	34
	34

(2)

- (b) A polypeptide has 51 amino acids in its primary structure.

- (i) What is the minimum number of DNA bases required to code for the amino acids in this polypeptide?

(1)

- (ii) The gene for this polypeptide contains more than this number of bases.

Explain why

(1)

(Total 8 marks)

Q7.

- (a) Describe how DNA is replicated.

(6)

- (b) The graph shows information about the movement of chromatids in a cell that has just started metaphase of mitosis.

Key

----- = distance between chromatids

———— = distance between each chromatid and the pole to which it is moving

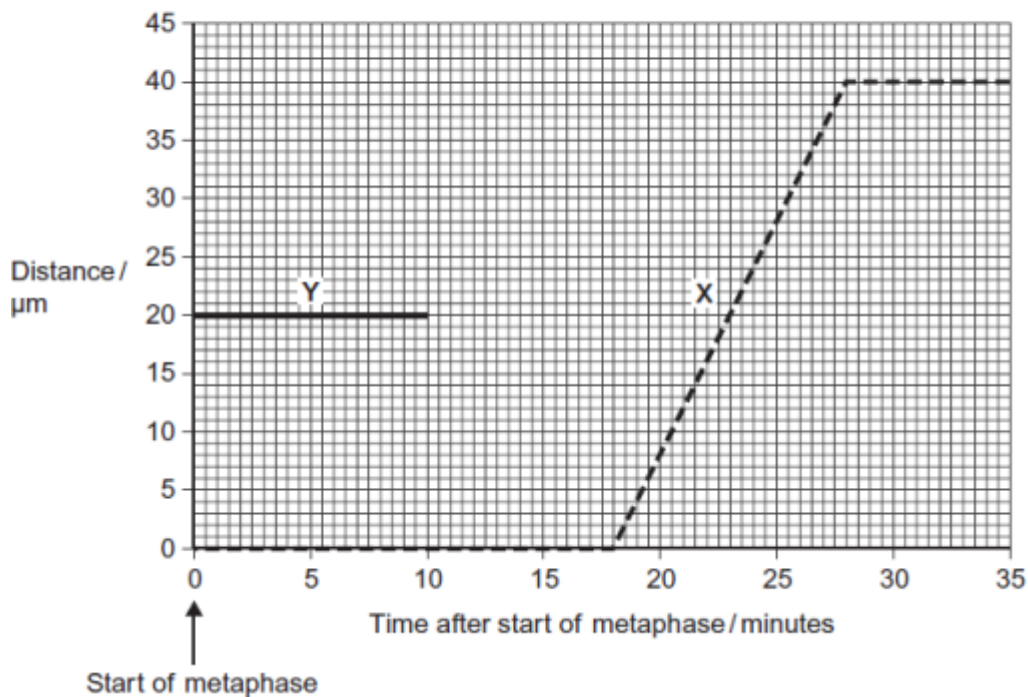

- (i) What was the duration of metaphase in this cell?

minutes

(1)

- (ii) Use line **X** to calculate the duration of anaphase in this cell.

minutes

(1)

- (iii) Complete line **Y** on the graph.

(2)

- (c) A doctor investigated the number of cells in different stages of the cell cycle in two tissue samples, **C** and **D**. One tissue sample was taken from a cancerous tumour. The other was taken from non-cancerous tissue. The table shows his results.

Stage of the cell cycle	Percentage of cells in each stage of the cell cycle	
	Tissue sample C	Tissue sample D
Interphase	82	45
Prophase	4	16
Metaphase	5	18
Anaphase	5	12
Telophase	4	9

- (i) In tissue sample **C**, one cell cycle took 24 hours. Use the data in the table to calculate the time in which these cells were in interphase during one cell cycle. Show your working.

Time cells in interphase _____ hours

(2)

- (ii) Explain how the doctor could have recognised which cells were in interphase when looking at the tissue samples.

(1)

- (iii) Which tissue sample, **C** or **D**, was taken from a cancerous tumour?
Use information in the table to explain your answer.

(2)

(Total 15 marks)

Q8.

- (a) DNA helicase is important in DNA replication. Explain why.

(2)

Scientists investigating DNA replication grew bacteria for several generations in a nutrient solution containing a heavy form of nitrogen (^{15}N). They obtained DNA from a sample of these bacteria.

The scientists then transferred the bacteria to a nutrient solution containing a light form of nitrogen (^{14}N). The bacteria were allowed to grow and divide twice. After each division, DNA was obtained from a sample of bacteria.

The DNA from each sample of bacteria was suspended in a solution in separate tubes. These were spun in a centrifuge at the same speed and for the same time. The diagram shows the scientists' results.

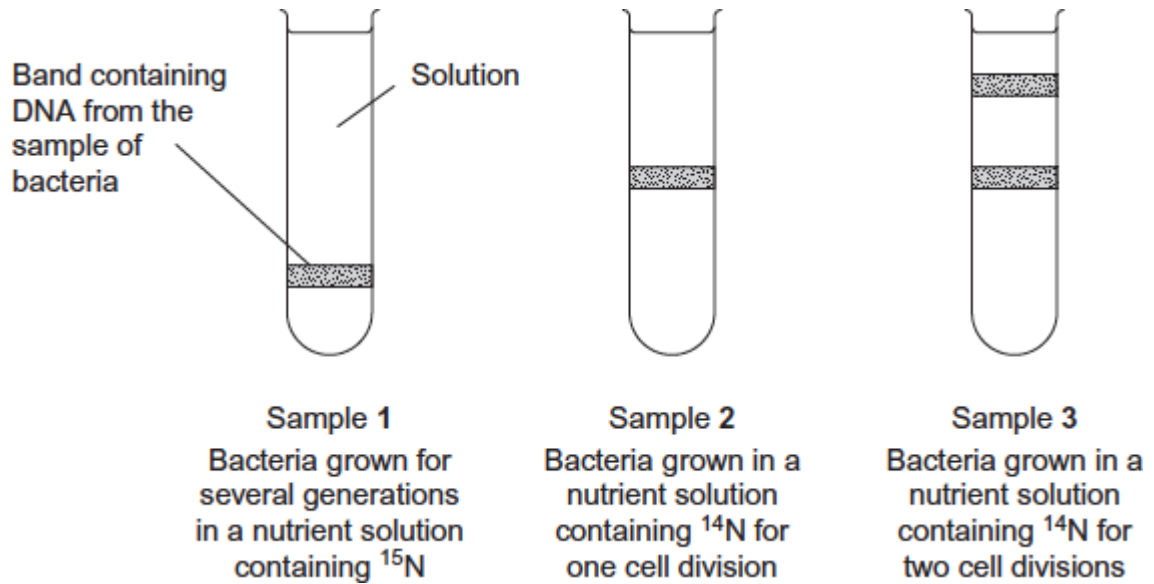

- (b) The table shows the types of DNA molecule that could be present in samples 1 to 3. Use your knowledge of semi-conservative replication to complete the table with a tick if the DNA molecule is present in the sample.

Sample	Type(s) of DNA molecule present in each sample		
	^{15}N ^{15}N 	^{15}N ^{14}N 	^{14}N ^{14}N
1			
2			
3			

(3)

- (c) Cytarabine is a drug used to treat certain cancers. It prevents DNA replication. The diagram shows the structures of cytarabine and the DNA base cytosine.

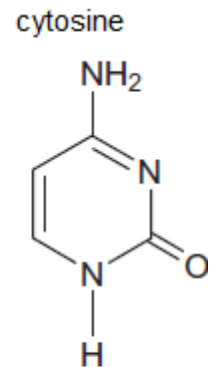
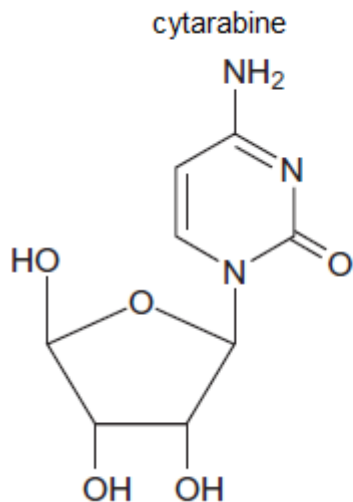

- (i) Use information in the diagram to suggest how cytarabine prevents DNA replication.

(2)

- (ii) Cytarabine has a greater effect on cancer cells than on healthy cells. Explain why.

(1)

(Total 8 marks)

Q9.

- (a) (i) Describe the role of DNA polymerase in DNA replication.

(1)

- (ii) Other than being smaller, give **two** ways in which prokaryotic DNA is different from eukaryotic DNA.

1. _____

2. _____

(2)

- (b) The table shows the percentage of each base in the DNA from three different organisms.

Organism	Percentage of each base in DNA			
	Adenine	Guanine	Thymine	Cytosine
Human	30.9	19.9	29.4	19.8
Grasshopper	29.4	20.5	29.4	20.7
Virus	24.0	23.3	21.5	31.2

- (i) Humans and grasshoppers have very similar percentages of each base in their DNA but they are very different organisms.

Use your knowledge of DNA structure and function to explain how this is possible.

(2)

- (ii) The DNA of the virus is different from that of other organisms. Use the table above and your knowledge of DNA to suggest what this difference is. Explain your answer.

[Extra space] _____

(2)

(Total 7 marks)

Q10.

Figure 1 shows one base pair of a DNA molecule.

Figure 1

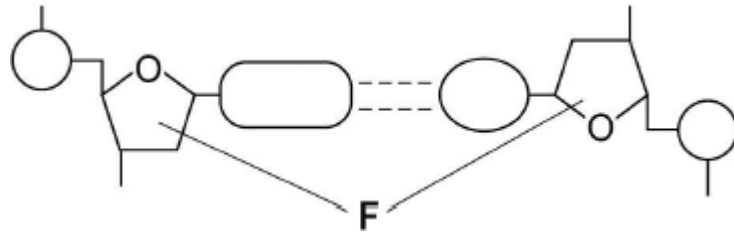

(a) Name part **F** of each nucleotide.

(1)

(b) Scientists determined that a sample of DNA contained 18% adenine.
 What were the percentages of thymine and guanine in this sample of DNA?

Percentage of thymine

Percentage of guanine

(2)

During replication, the two strands of a DNA molecule separate and each acts as a template for the production of a new strand.

Figure 2 represents DNA replication.

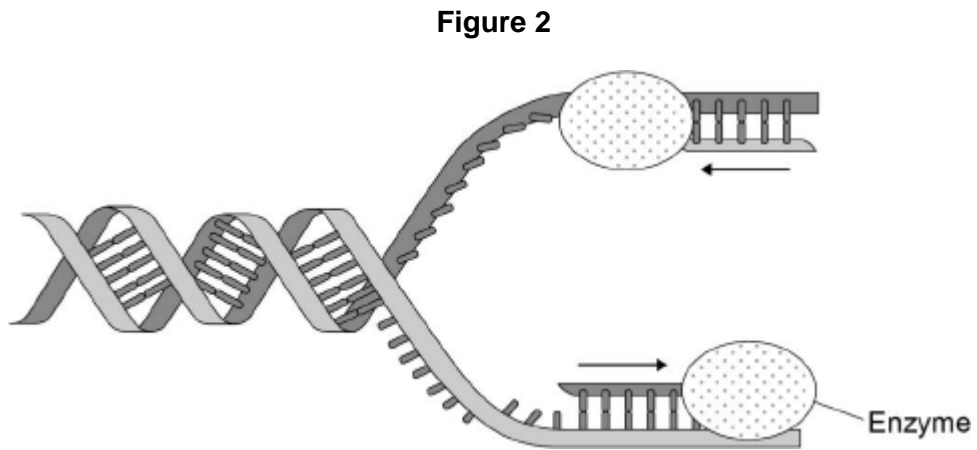

(c) Name the enzyme shown in **Figure 2**.

(1)

The arrows in **Figure 2** show the directions in which each new DNA strand is being produced.

(d) Use **Figure 1**, **Figure 2** and your knowledge of enzyme action to explain why the arrows point in opposite directions.

(4)
(Total 8 marks)

Q11.

(a) The genetic code is **degenerate** and **non-overlapping**.

Explain the meaning of:

Degenerate _____

Non-overlapping _____

(2)

The table shows a short section of a messenger RNA (mRNA) molecule and the section of a polypeptide for which it codes.

mRNA	G G G	G C U	U C A	C C G	G C A	A C G
Polypeptide	glycine	alanine	serine	proline	alanine	threonine

(b) Name the bases represented in the table by:

A _____

C _____

G _____

U _____

(2)

(c) Use information in the table to give the sequence of bases in **DNA** that codes for serine.

(1)
(Total 5 marks)

Q12.

Read the following passage.

Herpes simplex virus (HSV) infects nerve cells in the face, including some near the lips. Like many other viruses, HSV can remain inactive inside the body for years. When HSV becomes active, it causes cold sores around the mouth.

Human cells infected with a virus may undergo programmed cell death. While HSV is inactive inside the body, only one of its genes is transcribed. This gene is the latency-associated transcript (*LAT*) gene that prevents programmed cell death of an infected nerve cell.

5

Scientists have found that transcription of the *LAT* gene produces a microRNA. This microRNA binds to some of the nerve cell's own mRNA molecules. These mRNA molecules are involved in programmed cell death of nerve cells. The scientists concluded that production of this microRNA allows HSV to remain in the body for years.

10

Use information from the passage and your own knowledge to answer the following questions.

- (a) HSV infects nerve cells in the face (line 1). Explain why it infects **only** nerve cells.

(Extra space) _____

(3)

- (b) HSV can remain inactive inside the body for years (lines 2–3). Explain why this virus can be described as **inactive**.

(2)

- (c) Suggest **one** advantage of programmed cell death (line 4).

(1)

- (d) The scientists concluded that production of this microRNA allows HSV to remain in the body for years (lines 10–12).

Explain how this microRNA allows HSV to remain in the body for years.

(Extra space)

(4)

(Total 10 marks)

Q13.

The diagram shows part of a DNA molecule.

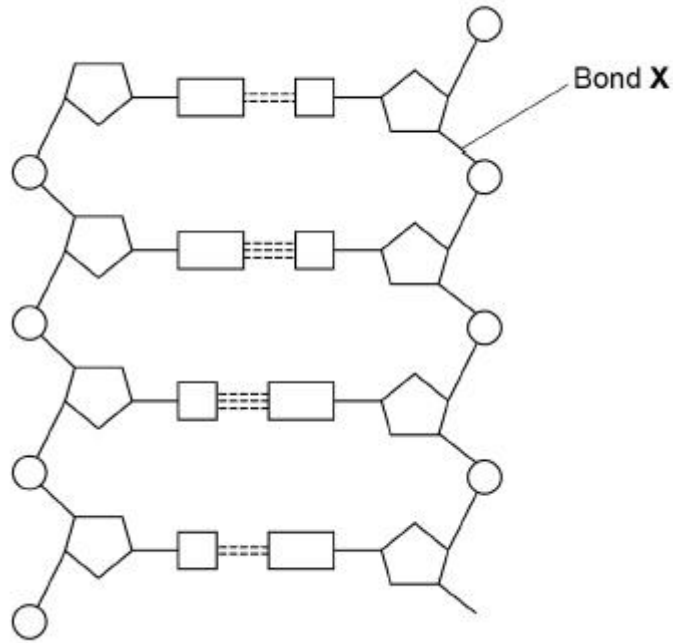

(a) How many nucleotides are shown in the diagram above?

(1)

(b) Name the type of bond labelled **X** in the diagram.

(1)

(c) The enzymes DNA helicase and DNA polymerase are involved in DNA replication.

Describe the function of each of these enzymes.

DNA helicase _____

DNA polymerase _____

(2)

(d) Adenosine triphosphate (ATP) is a nucleotide derivative.

Contrast the structures of ATP and a nucleotide found in DNA to give **two** differences.

1. _____

2. _____

(2)
(Total 6 marks)

Mark schemes

Q1.

- (a) **D** phosphate;
E pentose sugar/deoxyribose;
F (nitrogenous) base/ organic base/ thymine/adenine/ cytosine/guanine;

In D reject phosphorous

In E

Accept 5-carbon sugar

Reject sugar alone

3

- (b)

	DNA	RNA
	double-stranded	single-stranded
	deoxyribose	ribose
	Thymine/T	Uracil/U
	very large/long	very small/short

Accept double helix for DNA

Accept longer and shorter

Need comparison but could be in one box

List rule applies.

2 max

[5]

Q2.

- (a) Any two of:

DNA	RNA
Large molecule	Smaller
Double stranded	Single stranded
Contains Thymine (T)	Contains Uracil (U)
Contains deoxyribose	Contains ribose

2 max

- (b) Base sequence (on DNA/in gene);
 Determines sequence of amino acids;
 By determining base sequence on (messenger) RNA;
 Code is a triplet code/three base code for an amino acid;

2 max

- (c) Pairs of chromosomes/two chromosomes;
 With genes for same features / with same genes;
 At same loci / in same sequence;

Accept same alleles

2 max

[6]

Q3.

- (a) **X**, phosphate;

Y, deoxyribose / pentose / 5-carbon sugar;

Z, (nitrogenous) base;

(accept named base)

3

(b) (specific) hydrogen (bonds);

1

(c) thymine 28% so adenine 28%
therefore 44% cytosine and guanine;
therefore 22% cytosine;

(idea of equal amounts T and A, C and G – 1 mark, correct
answer 2 marks)

2

[6]

Q4.

(a) (i) Deoxyribose;

pentose / 5C sugar = neutral

1

(ii) Phosphate / Phosphoric acid;

phosphorus / P = neutral

1

(b) Hydrogen (bonds);

1

(c) 381 / 384 / 387;

1

(d) (Gln) Met Met Arg Arg Arg Asn;

1

(e) Change in (sequence of) amino acids / primary structure;

Change in hydrogen / ionic / disulfide bonds leads to change in tertiary
structure / active site (of enzyme);

Substrate cannot bind / no enzyme-substrate complexes form;

Q Reject = different amino acids are formed

3

[8]

Q5.

(a)

DNA	✓	2
mRNA	✗	1
tRNA	✓	1

One mark for each correct column

Regard blank as incorrect in the context of this question

Accept numbers written out: two, one, one

- (b) (i) Marking principles
1 mark for complete piece transcribed;

Correct answer
UGU CAU GAA UGC UAG

1 mark for complementary bases from sequence transcribed;
but allow 1 mark for complementary bases from section transcribed, providing all four bases are involved

2

- (ii) Marking principle
1 mark for bases corresponding to exons taken from (b)(i)

Correct answer
UGU UGC UAG
If sequence is incorrect in (b)(i), award mark if section is from exons. Ignore gaps.

1

[5]

Q6.

- (a) (i) Repeating units / nucleotides / monomer / molecules;
Allow more than one, but reject two

1

- (ii) 1. C = hydrogen bonds;
2. D = deoxyribose;
Ignore sugar
3. E = phosphate;
Ignore phosphorus, Ignore molecule

3

- (iii)

Name of base	Percentage
Thymine	34
Cytosine / Guanine	16
Adenine	34
Cytosine / Guanine	16

Spelling must be correct to gain MP1
First mark = names correct
Second mark = % correct, with adenine as 34%

2

- (b) (i) 153;

1

- (ii) Some regions of the gene are non-coding / introns / start / stop code /

triplet / there are two DNA strands;
 Allow addition mutation
 Ignore unqualified reference to mutation
 Accept reference to introns and exons if given together
 Ignore 'junk' DNA / multiple repeats

1

[8]

Q7.

- (a) 1. Strands separate / H-bonds break;
 1. **Q Neutral:** strands split
 1. **Accept:** strands unzip
2. DNA helicase (involved);
3. Both strands / each strand act(s) as (a) template(s);
4. (Free) nucleotides attach;
 4. **Neutral:** bases attach
 4. **Accept:** nucleotides attracted
5. Complementary / specific base pairing / AT and GC;
6. DNA polymerase joins nucleotides (on new strand);
 6. **Reject:** if wrong function of DNA polymerase
7. H-bonds reform;
8. Semi-conservative replication / new DNA molecules contain one old strand and one new strand;
 8. **Reject:** if wrong context e.g. new DNA molecules contain half of each original strand

6 max

- (b) (i) 18;
 Do not accept 17.5

1

- (ii) 10;

1

- (iii) 1. Horizontal until 18 minutes;
 Allow + / - one small box
2. (Then) decreases as straight line to 0 μm at 28 minutes;
 2. Allow lines that start from the wrong place, ending at 0 at 28 minutes

2

- (c) (i) Two marks for correct answer of 19.68 or 19.7;;
 Accept 19hrs 41mins

One mark for incorrect answers in which candidate clearly multiplies by 0.82;

Allow one mark for incorrect answers that clearly show 82% of 24 (hours)

2

- (ii) 1. No visible chromosomes / chromatids / visible nucleus;

1

- (iii) **D** (no mark)

1. Lower % (of cells) in interphase / higher % (of cells) in mitosis / named stage of mitosis;

1. Accept: 'less' or 'more' instead of '%'

1. Do not accept: higher % (of cells) in each / all stage(s)

2. (So) more cells dividing / cells are dividing quicker;

2. Accept: uncontrolled cell division

2. Do not award if Tissue **C** is chosen

2

[15]

Q8.

- (a) 1. Separates / unwinds / unzips strands / helix / breaks H-bonds;

1. **Q Neutral:** strands / helix split

1. Accept: unzips bases

2. (So) nucleotides can attach / are attracted / strands can act as templates;

2. **Q Neutral:** bases can attach

2. Neutral: helix can act as a template

2

- (b)

Sample	Type(s) of DNA molecule present in each tube		
	$^{15}\text{N}/^{15}\text{N}$	$^{15}\text{N}/^{14}\text{N}$	$^{14}\text{N}/^{14}\text{N}$
1	✓		
2		✓	
3		✓	✓

One mark for each correct row

3

- (c) (i) 1. Similar shape / structure (to cytosine) / added instead of cytosine / binds to guanine;

1. Accept: idea that only one group is different

1. Reject: same shape

2. Prevents (complementary) base pairing / prevents H-bonds

forming / prevents formation of new strand / prevents strand elongation / inhibits / binds to (DNA) polymerase;

2. *Accept: prevents cytosine binding*

Neutral: 'prevents DNA replication' as given in the question stem

Neutral: 'competitive inhibitor' unqualified

Neutral: inhibits DNA helicase

2

(ii) (Cancer cells / DNA) divide / replicate fast(er) / uncontrollably;

Accept: converse argument for healthy cells

1

[8]

Q9.

(a) (i) Joins nucleotides (to form new strand).

Accept: joins sugar and phosphate / forms sugar-phosphate backbone

Reject: (DNA polymerase) forms base pairs / hydrogen bonds

1

(ii) (Prokaryotic DNA)

1. Circular / non-linear (DNA);

Accept converse for eukaryotic DNA

Ignore: references to nucleus, binary fission, strands and plasmids

2. Not (associated) with proteins / histones;

Accept does not form chromosomes / chromatin

3. No introns / no non-coding DNA.

Accept only exons

Q *Neutral: no 'junk' DNA*

2 max

(b) (i) 1. Have different genes;

Reject: different alleles

2. (Sobases / triplets) are in a different sequence / order;

Accept: base sequence that matters, not percentage

3. (So) different amino acid (sequence / coded for) / different protein / different polypeptide / different enzyme.

Unqualified 'different amino acids' does not gain a mark

Reject: references to different amino acids formed

Ignore: references to mutations / exons / non-coding / introns

2 max

(ii) (Virus DNA)

1. A does not equal T / G does not equal C;

Accept: similar for equal

Accept: virus has more C than G / has more A than T

2. (So) no base pairing;
3. (So) DNA is not double stranded / is single stranded.

2 max

[7]

Q10.

(a) Deoxyribose.

1

- (b)
1. Thymine 18 (%);
 2. Guanine 32 (%).

2

(c) DNA polymerase.

1

- (d)
1. (**Figure 1** shows) DNA has antiparallel strands / described;
 2. (**Figure 1** shows) shape of the nucleotides is different / nucleotides aligned differently;
 3. Enzymes have active sites with specific shape;
 4. Only substrates with complementary shape / only the 3' end can bind with active site of enzyme / active site of DNA polymerase.

4

[8]

Q11.

- (a)
1. Degenerate: more than one (base) triplet for each amino acid;
 2. Non-overlapping: each base is part of only one triplet.
Accept codon (as would be applicable to mRNA code)

2

(b) A = adenine

C = cytosine

G = guanine

U = uracil

All four correct = 2

One error = 1

Two or more errors = 0

2 max

(c) AGT;

1

[5]

Q12.

- (a)
1. Outside of virus has antigens / proteins;
 2. With complementary shape to receptor / protein in membrane of cells;
 3. (Receptor / protein) found only on membrane of nerve cells.

Accept converse argument

3

- (b) 1. No more (nerve) cells infected / no more cold sores form;
2. (Because) virus is not replicating.

2

- (c) Prevents replication of virus.

1

- (d) MicroRNA binds to cell's mRNA (no mark)

1. (Binds) by specific base pairing;
2. (So) prevents mRNA being read by ribosomes;
3. (So) prevents translation / production of proteins;
4. (Proteins) that cause cell death.

4

[10]

Q13.

- (a) 8;

Accept eight

1

- (b) Phosphodiester (bond);

Accept phonetic spellings

1

- (c) 1. DNA helicase – (unwinding DNA and) breaking hydrogen bonds / bonds between chains / bases / strands;
2. DNA polymerase – joins (adjacent) nucleotides **OR** forms phosphodiester bond / sugar-phosphate backbone;

1. *Accept H bonds.*

1. *Accept hydrolyses for breaks*

2. *Reject forms hydrogen bonds (between nucleotides / bases)*

2

- (d) 1. ATP has ribose **and** DNA nucleotide has deoxyribose;
2. ATP has 3 phosphate (groups) **and** DNA nucleotide has 1 phosphate (group);
3. ATP – base always adenine **and** in DNA nucleotide base can be different / varies;

Both parts of each MP needed

3. *Reject Uracil / U*

3. *Accept C, T or G for different bases*

Accept annotated diagram for any of the three marks

2 max

[6]