

Volume
One

**ST MARY'S SCIENCE
DEPARTMENT:
PHYSICS**

**A LEVEL PHYSICS YEAR 1
STUDENT INDEPENDENT BOOK
3.4.1: FORCES AND ENERGY
VOLUME ONE**

NAME	
PHYSICS CLASS	
MODULE TEACHER	
ALPS GRADE	



**A-LEVEL PHYSICS
TOPIC 4
INDEPENDENT WORK BOOK 1**

**THIS MUST
BE BROUGHT
TO ALL
PHYSICS
LESSONS.**



Contents

3.4.1.1 Scalars and Vectors

3.4.1.2 Moments

3.4.1.3 Motion Along a Straight Line

3.4.1.4 Projectile Motion

OVERVIEW

Vectors and their treatment are introduced followed by development of the student's knowledge and understanding of forces, energy and momentum.

The section continues with a study of materials considered in terms of their bulk properties and tensile strength.

IMPORTANT NOTE

This book contains all of the activities you can carry out independently in your study periods to enhance your understanding in A-Level Physics.

You may work through the activities in this book and mark this work yourself. Your work will then be reviewed by your teacher in KS5 file checks. This work is in addition to the class work and homework you carry out.

This book may also be used as a revision resource for intervention, internal assessments and external assessments.

Please keep this in your student file.

As part of this course you are expected to **read through this preparatory reading book** and **complete the independent study tasks**.

This work will not be assessed but will be monitored by your class teacher.

This must be completed by the deadline set by your class teacher.



SECTION 1

INDEPENDENT STUDY TASK

Instructions

Read through the information from the student preparatory book and then produce revision posters on the key points highlighted on the following pages.

These notes should be used as a revision resource for assessments.

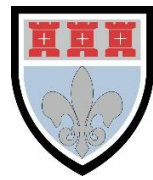

INDEPENDENT STUDY TASK 1

Produce an **information sheet** on vector addition and vector resolution.

This is an independent study task to be carried out outside of lesson.

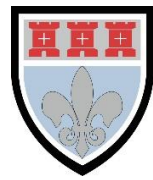

INDEPENDENT STUDY TASK 2

Produce an **information sheet** on moments.

This is an independent study task to be carried out outside of lesson.

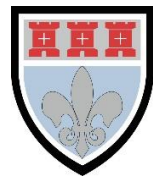

INDEPENDENT STUDY TASK 3

Produce an **information sheet** on the equations of motion for uniform acceleration.

This is an independent study task to be carried out outside of lesson.

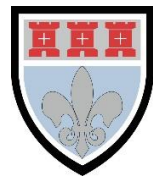

INDEPENDENT STUDY TASK 4

Produce an **information sheet** on projectile motion.

This is an independent study task to be carried out outside of lesson.



SECTION 2

KNOWLEDGE CHECKER

Instructions

Read through the information from the student preparatory book and then answer the following questions from the different parts of the topics.

These questions are designed to introduce the different parts of this module.

Use the mark schemes to review your knowledge and understanding.

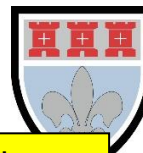

QUESTIONS

Use the preparatory reading notes to answer these questions.

A1. Explain the difference between a scalar quantity and a vector quantity.

[1 Mark]

.....
.....

A2. How can the horizontal component of a force be calculated?
Assume the angle of the force is measured from the horizontal.

[1 Mark]

.....
.....

A3. How can the vertical component of a force be calculated?
Assume the angle of the force is measured from the horizontal.

[1 Mark]

.....
.....

A4. What is a moment?

[1 Mark]

.....
.....

A5. What is a couple of force?

[1 Mark]

.....
.....

A6. A force of 54N acts at a perpendicular distance of 84cm from a pivot. Calculate the moment of the force.

[1 Mark]

.....
.....

Use the preparatory reading notes to answer these questions.



A7. A girl of mass 40kg sits 1.5m from the middle of a seesaw.
Show that her brother, mass 50kg, must sit 1.2m from the middle if the seesaw is to balance.

[1 Mark]

.....

.....

.....

A8. What are the differences between mass and weight?

[1 Mark]

.....

.....

.....

A9. What is meant by the centre of mass of an object?

[1 Mark]

.....

.....

A10. Why will an object topple if its centre of mass is not over the object's base?

[1 Mark]

.....

.....

A11. Sketch a displacement-time graph to show constant velocity.

[1 Mark]

.....

.....

Use the preparatory reading notes to answer these questions.



A12. Sketch a displacement-time graph to show acceleration.

[1 Mark]

A13. Sketch a displacement-time graph to show deceleration.

[1 Mark]

A14. How do you calculate acceleration from a velocity-time graph?

[1 Mark]

.....
.....

A15. What does the area under an acceleration-time graph tell you?

[1 Mark]

.....
.....

Use the preparatory reading notes to answer these questions.



A16. Describe the main advantages of ICT over traditional methods for the collection and display of motion data.

[1 Mark]

.....

.....

.....

A17. Write out the four uniform acceleration equations.

[1 Mark]

.....

.....

.....

.....

A18. A small steel ball is dropped from a height of 1.5m. Calculate its speed as it hits the ground.

[1 Mark]

.....

.....

.....

.....

Use the preparatory reading notes to answer these questions.



ADVANCED SECTION

A19. The wind is creating a horizontal force of 20.0N on a falling rock of weight 75N. Calculate the magnitude and direction of the resultant force.

[1 Mark]

.....

.....

.....

.....

A20. A glider is travelling at a velocity of 20.0m/s at an angle of 15° below the horizontal. Calculate the horizontal and vertical components of the glider's velocity.

[1 Mark]

.....

.....

.....

.....

A21. A drive is changing his flat tyre. The moment required to undo the nut is 60Nm. He uses a 0.40m long double ended wheel wrench. Calculate the force that he must apply at the end of each end of the wrench.

[1 Mark]

.....

.....

.....

.....

Use the preparatory reading notes to answer these questions.



A22. Describe an experiment to find the centre of mass of an object of uniform density with a constant thickness and irregular cross-section.

[1 Mark]

.....

.....

.....

.....

Questions **A23-A24** refer to the following statement.

A skydiver from a helicopter hovering at a height of 1500m from the ground.

She accelerates due to gravity for 5.0s.

A23. Calculate her maximum vertical velocity (assume no air resistance).

[1 Mark]

.....

.....

.....

.....

A24. Calculate how far she falls in this time.

[1 Mark]

.....

.....

.....

.....

Use the preparatory reading notes to answer these questions.



ANSWERS

A1. Explain the difference between a scalar quantity and a vector quantity.

[1 Mark]

Scalar quantities have a magnitude only. Vector quantities have a magnitude and direction.

A2. How can the horizontal component of a force be calculated?

Assume the angle of the force is measured from the horizontal.

[1 Mark]

$$V_H = V \cos \theta$$

A3. How can the vertical component of a force be calculated?

Assume the angle of the force is measured from the horizontal.

[1 Mark]

$$V_V = V \sin \theta$$

A4. What is a moment?

[1 Mark]

A moment is the turning effect of a force.

Moment = Force x Perpendicular Distance from the Pivot

A5. What is a couple of force?

[1 Mark]

A pair of forces of equal size which act parallel to each other, but in opposite directions.

A6. A force of 54N acts at a perpendicular distance of 84cm from a pivot. Calculate the moment of the force.

[1 Mark]

$$\text{Moment} = 54 \times 0.84 = 45.36 = 45\text{Nm}$$

A7. A girl of mass 40kg sits 1.5m from the middle of a seesaw.

Show that her brother, mass 50kg, must sit 1.2m from the middle if the seesaw is to balance.

[1 Mark]

For the see-saw to balance, the clockwise and anti-clockwise moments must be the same.

Clockwise Moment = Anti-clockwise Moment

$$40 \times 1.5 = 50 \times 1.2$$

$$60 = 60$$

A8. What are the differences between mass and weight?

[1 Mark]

Mass is the amount of matter in it.

Weight is the force experienced by a mass due to a gravitational field.

A9. What is meant by the centre of mass of an object?

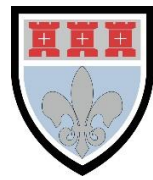

The single point that you can consider its whole weight to act through.

A10. Why will an object topple if its centre of mass is not over the object's base?

[1 Mark]

The object will produce a resultant moment if the centre of mass is not over the base, this causes the object to topple.

A11. Sketch a displacement-time graph to show constant velocity.

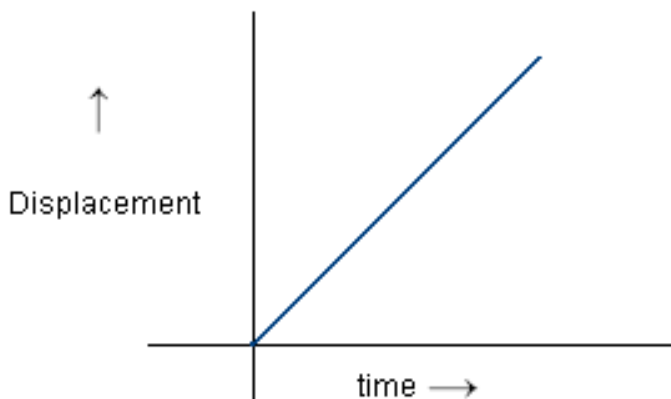
[1 Mark]

A12. Sketch a displacement-time graph to show acceleration.

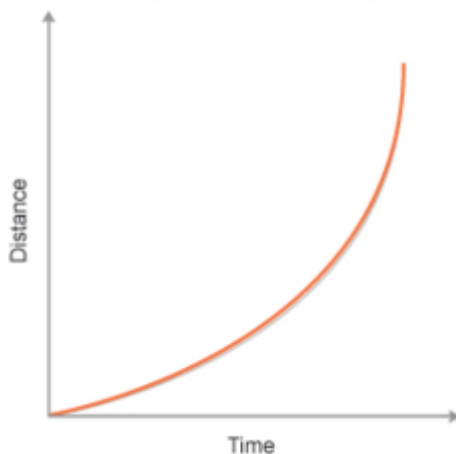
[1 Mark]

A13. Sketch a displacement-time graph to show deceleration.

[1 Mark]

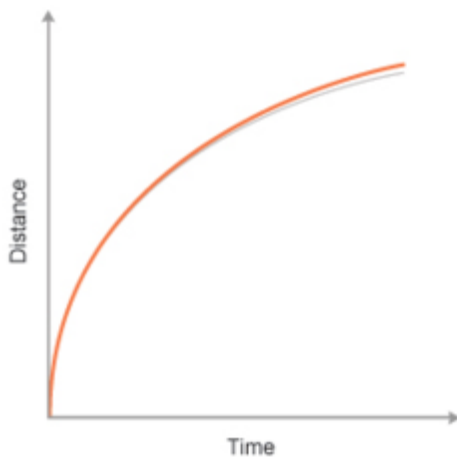

A14. How do you calculate acceleration from a velocity-time graph?

[1 Mark]

The acceleration is the gradient of the velocity-time graph.

A15. What does the area under an acceleration-time graph tell you?

[1 Mark]

The area under the acceleration-time graph gives the object's change in velocity.

A16. Describe the main advantages of ICT over traditional methods for the collection and display of motion data.

[1 Mark]

The data is more accurate – you do not have a large reaction time.

Automatic systems have a much higher sampling rate than humans – most ultrasound position detectors can take a reading ten times every second.

The data can be displayed in real time.

A17. Write out the four uniform acceleration equations.

[1 Mark]

$$s = ut + \frac{1}{2} at^2$$

$$v^2 = u^2 + 2as$$

$$v = u + at$$

$$s = \left(\frac{u + v}{2} \right) t$$

A18. A small steel ball is dropped from a height of 1.5m. Calculate its speed as it hits the ground.

[1 Mark]

$$u = 0 \quad s = 1.5\text{m} \quad a = g = -9.81 \text{ m/s}^2$$

$$s = ut + \frac{1}{2} at^2$$

$$t = \sqrt{(2 \times 1.5) / -9.81} = 0.5539 = 0.55 \text{ seconds}$$

ADVANCED SECTION

A19. The wind is creating a horizontal force of 20.0N on a falling rock of weight 75N. Calculate the magnitude and direction of the resultant force.

[1 Mark]

$$F^2 = 20^2 + 75^2 = 6025$$

$$F = 78\text{N}$$

$$\text{Tan } \theta = 20 / 75 = 0.266$$

$$\theta = 15^\circ \text{ to the vertical.}$$

A20. A glider is travelling at a velocity of 20.0m/s at an angle of 15° below the horizontal. Calculate the horizontal and vertical components of the glider's velocity.

[1 Mark]

$$V_H = 20\cos 15 = 19 \text{ m/s}$$

$$V_V = 20\sin 15 = 5.2 \text{ m/s}$$

A21. A drive is changing his flat tyre. The moment required to undo the nut is 60Nm. He uses a 0.40m long double ended wheel wrench.

Calculate the force that he must apply at the end of each end of the wrench.

[1 Mark]

$$\text{Moment} = \text{Force} \times \text{Distance}$$

$$60 = 0.40 F$$

$$F = 150\text{N}$$

A22. Describe an experiment to find the centre of mass of an object of uniform density with a constant thickness and irregular cross-section.

[1 Mark]

Hang the object freely from a point. Hang a plumb bob from the same point and use it to draw a vertical line down the object.

Repeat for a different point and find the point of intersection. The centre of mass is halfway through the thickness of the object at the point of intersection.

Questions **A23-A24** refer to the following statement.

A skydiver from a helicopter hovering at a height of 1500m from the ground.

She accelerates due to gravity for 5.0s.

A23. Calculate her maximum vertical velocity (assume no air resistance).

[1 Mark]

$$u = 0 \text{ m/s} \quad v = ? \quad a = -g = -9.81\text{m/s}^2 \quad t = 5 \text{ seconds}$$

$$v = u + at = 0 + (5 \times -9.81)$$

$$v = -49 \text{ m/s}$$

A24. Calculate how far she falls in this time.

[1 Mark]

$$s = ut + \frac{1}{2} at^2$$

$$s = 0 + \frac{1}{2} \times -9.81 \times 5^2$$

$$s = 120\text{m}$$



SECTION 3

QUESTIONS

Instructions

Read through the information from the student preparatory book and then answer the following questions from the different parts of the topics.

Use the mark schemes to review your knowledge and understanding.



TOPIC: 3.4.1.1 Scalars and Vectors

SPEC CHECK

Specification	Completed?
Nature of scalars and vectors. Examples should include: velocity/speed, mass, force/weight, acceleration, displacement/distance.	
Addition of vectors by calculation or scale drawing. Calculations will be limited to two vectors at right angles. Scale drawings may involve vectors at angles other than 90° .	
Resolution of vectors into two components at right angles to each other. Examples should include components of forces along and perpendicular to an inclined plane. Problems may be solved either using resolved forces or the use of a closed triangle.	
Conditions for equilibrium for two or three coplanar forces acting at a point. Appreciation of the meaning of equilibrium in the context of an object at rest or moving with constant velocity.	
Investigation of the conditions for equilibrium for three coplanar forces acting at a point using a force board.	



FACT RECALL

- R1.** What is the difference between a scalar and a vector?
- R2.** What name is given to a vector formed by adding vectors together?
- R3.** If a body is in equilibrium, what is the sum of the forces acting on it?
- R4.** Explain what equilibrium means in the context of a moving object.

APPLICATION

A1. Without drawing a scale diagram, find the magnitude and direction of a paper plane's resultant velocity, v , shown below.

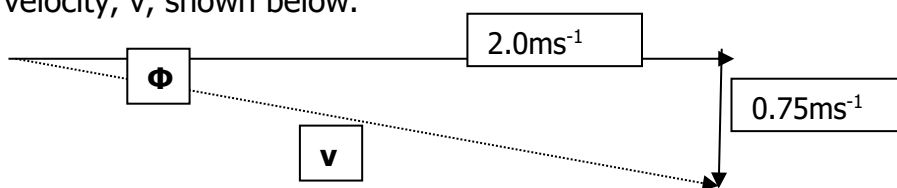

A2. Without drawing a scale diagram, find the horizontal and vertical components of this force.

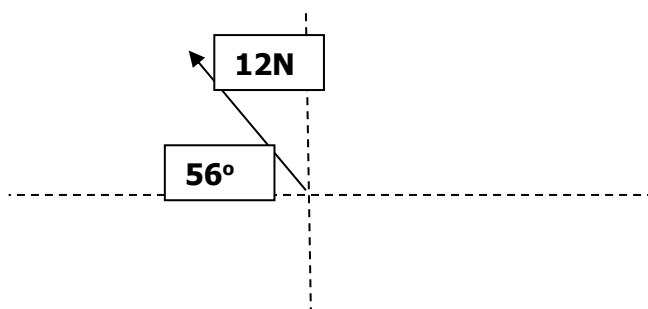

A3. Use a scale diagram to find the resultant of a 2.9 N force north and 4.1 N force east.

A4. A brick with a weight of 20.0 N is on a slope at 25° to the horizontal.

A4.1 Find the size of the force acting on it down the slope.

A4.2 Find the size of the reaction force exerted on it by the slope.

A5. Show with a vector triangle that an object is in equilibrium if only these forces are acting on it: 12 N acting east, 5.0 N north, 13 N at 23° anticlockwise from west.

A6. The three forces are in equilibrium. Find the magnitude of force, F .

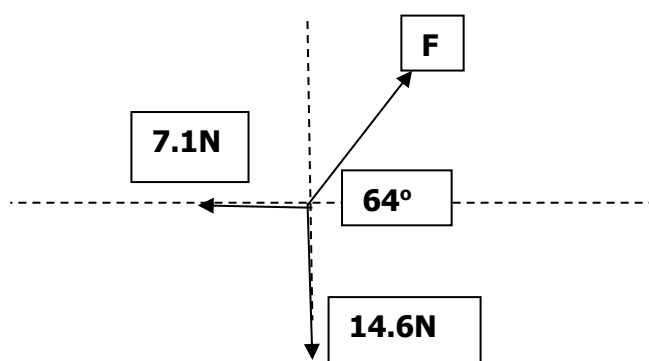

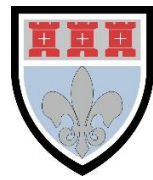

ANSWERS

R1. A scalar quantity has only size, while a vector quantity has size and direction.

R2. The resultant vector.

R3. The sum of all forces acting on a body in equilibrium is zero.

R4. For a moving object in equilibrium there is no resulting force, so the object will continue to move at a constant velocity.

A1. $V^2 = 2.0^2 + 0.75^2$
 $V = 2.136 = \mathbf{2.1ms^{-1}}$

$\Phi = \tan^{-1}(0.75/2.0) = 20.556 = \mathbf{21^\circ}$

The resultant velocity is $2.1ms^{-1}$ at 21° down from the horizontal.

A2. Horizontal Component = $F \cos\theta = 12\cos56^\circ = 6.710 = \mathbf{6.7N}$
Vertical Component = $F \sin\theta = 12\sin56^\circ = 9.948 = \mathbf{9.9N}$

A3. The resultant force is 5.0N on a bearing of 055° .

A4.1 $F_1 = \sin25^\circ \times 20.0 = 8.452 = \mathbf{8.5N}$

A4.2 $F_2 = \cos25^\circ \times 20.0 = 18.126 = \mathbf{18N}$.

A5. Draw a scale diagram of the forces – they should form a closed triangle.

A6. $F^2 = (7.1^2 + 14.6^2)$
 $F = 16.234 = \mathbf{16N}$



PRACTICAL SKILLS

Complete the following practical skills-based task to improve your experimental understanding of this part of the course in preparation for **Physics Paper 3**.

P1. Define a vector quantity.

[1 Mark]

.....
.....

P2. Identify which of the following quantities are vectors and which are scalars.

[4 Marks]

weight distance momentum kinetic energy mass
velocity displacement acceleration temperature upthrust

P3. A rope is pulled with a tension of 50 N at an angle of 30° to the horizontal.

P3.1 Calculate the horizontal component of the tension.

[1 Mark]

.....
.....

P3.2 Calculate the vertical component of the tension.

[1 Mark]

.....
.....

P4. A parent is pushing their child on a swing. They stop the child momentarily by pulling on the swing seat with a horizontal force. The swing makes an angle of 40° to the vertical. The child and swing seat have a mass of 25 kg.

P4.1 Draw a free-body diagram of the forces acting on the child.

[3 Marks]



P4.2 Determine the tension in the swing.

[2 Marks]

.....

.....

.....

P4.3 Find the force, F , with which the parent is holding the swing.

[2 Marks]

.....

.....

.....

P5. From OCR Physics A G481 Mechanics May 2011 (Question 3c)

Figure 1 shows the forces acting on a stage light of weight 120 N held stationary by two separate cables.

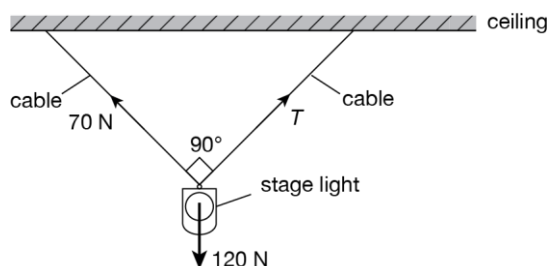

Figure 1

The angle between the two cables is 90° . One cable has tension 70 N and the other has tension T .

P5.1 State the magnitude and the direction of the **resultant** of the tensions in the two cables.

[2 Marks]

.....

.....

.....

P5.2 Sketch a labelled vector triangle for the forces acting on the stage light. Hence, determine the magnitude of the tension T .

[4 Marks]

.....

.....

.....



ANSWERS

Answers for follow-up sheet

P1. A vector quantity has both magnitude and direction. (1 mark)

P2. Award a maximum of 4 marks; deduct 1 mark for each incorrect answer.

Scalars: distance, kinetic energy, mass, temperature.

Vectors: weight, momentum, displacement, velocity, acceleration, upthrust.

P3.1 Horizontal component = $50 \cos 30^\circ = 43 \text{ N}$. (1 mark)

P3.2 Vertical component = $50 \sin 30^\circ = 25 \text{ N}$. (1 mark)

P4.1 Award a maximum of 3 marks, 1 mark for each correctly labelled force.

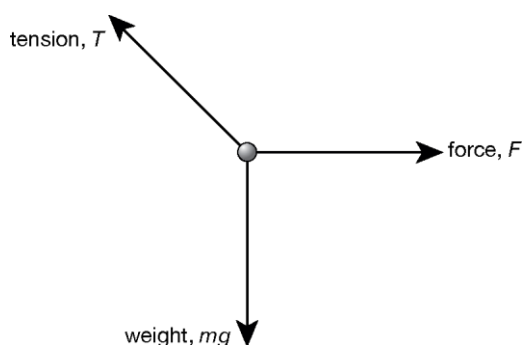

Allow: mg or W for weight.

P4.2 $T \cos 40 = mg$ (1 mark)

$$T = \frac{mg}{\cos 40} = 320 \text{ N} \quad (1 \text{ mark})$$

P4.3 $F = T \sin 40$ (1 mark)

$$F = 205 \text{ N} \quad (1 \text{ mark})$$

P5. From OCR Physics A G481 Mechanics mark scheme May 2011 (Question 3c)

5.1	Magnitude is 120 (N) / equal to weight Direction is (vertically) up / opposite to weight	B1 B1	
5.2	Correct diagram Correct detail on diagram $120^2 + 70^2 = T^2$ $T = 97 \text{ (N) or } 97.5 \text{ (N)}$	M1 A1 C1 A1	<p>Note: For the M1 mark, the basic diagram must have all sides labelled (70, 120, and T) and the angle between 70 (N) and T is judged by eye to be 90°</p> <p>Note: For the A1 mark, all the arrows are marked and cyclic</p> <p>Note: For the C1 and A1 marks, $T = \sqrt{120^2 + 70^2} = 140$ scores zero</p> <p>Allow: 2 marks for T in the range of 94 (N) to 100 (N) if scale drawing is done</p>



CHALLENGE QUESTION

To assess your understanding, answer the following higher-level question on this topic.

- 21 (a) Physical quantities can be added together. Velocity and mass are examples of two different types of physical quantities.
Discuss how the addition of two velocities differs from the addition of two masses.

.....

.....

.....

..... [2]

- (b) Fig. 21 shows a stationary trolley on a smooth ramp.

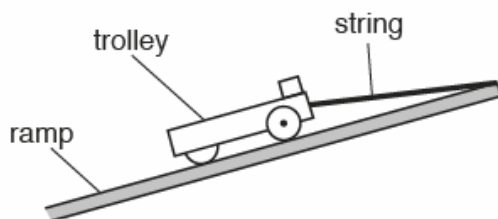

Fig. 21

A short length of string is attached between the end of the trolley and the top of the ramp. Assume that the frictional force acting on the trolley is negligible when it is stationary or when it is moving.

- (i) Other than the normal contact force, there are two other forces acting on the stationary trolley.
On Fig. 21, draw arrows to show these two forces. You do not need to name these forces. [1]

- (ii) The string is cut at time $t = 0$. The trolley travels down the ramp with a constant acceleration of 3.0 m s^{-2} .
Calculate the time t taken by the trolley to travel a distance of 0.80 m down the ramp.

$t = \dots\dots\dots \text{ s}$ [2]

Turn over



- 22 A group of engineers are testing a new car. They are investigating how the braking distance x of the car varies with its initial speed u when a constant braking force is applied. Fig. 22 shows the data points plotted on a u^2 against x graph. The straight line of best fit has been drawn through the data points.

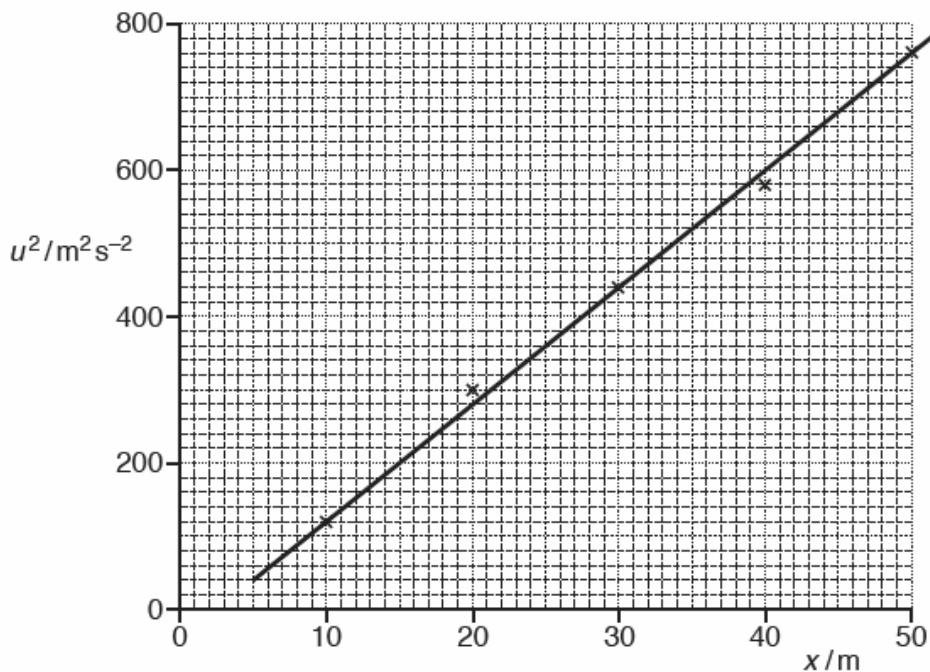

Fig. 22

The theoretical relationship between u and x for the car is

$$u^2 = 2ax$$

where a is the magnitude of the deceleration of the car.

- (a) Fig. 22 shows that the straight line does not pass through the origin because of a systematic error in the measurement of the braking distance x . The u^2 values are accurate. Suggest why a systematic error in x does not introduce any difference between the actual value and the experimental value for the deceleration of the car.

.....

[11

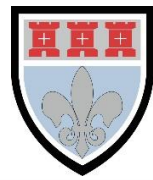

- (b) The mass of the car is 920kg.
Use the gradient of the line drawn in Fig. 22 to determine the braking force F acting on the car.

$F = \dots\dots\dots$ N [3]

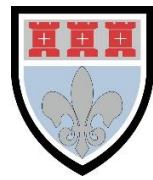

ANSWERS

Question	Answer	Marks	Guidance
21 (a)	Mass is a scalar (quantity) and velocity is a vector (quantity). (Addition of) velocity depends on direction / sign / vector triangle / resolving (ORA)	B1 B1	Allow 'Velocity can be cancelled out'
(b) (i)	An arrow from trolley to ramp along the string (for the tension) and a downwards arrow from the trolley (for the weight).	B1	Allow arrows in correct directions anywhere on Fig. 21 Not arrow for the tension parallel to the ramp Not arrow perpendicular to the ramp for the weight Not two arrow heads in opposite directions along the string for the tension
(ii)	$(s = \frac{1}{2} at^2); 0.80 = \frac{1}{2} \times 3.0 \times t^2$ (Any subject) $t = 0.73$ (s)	C1 A1	Note: Apply SF penalty if 0.7 s is on the answer line or the final answer Allow 1 mark for 0.40 (s); 9.8 m s ⁻² used instead of 3.0 m s ⁻² Allow full credit for alternative methods, e.g: $v^2 = 2 \times 0.80 \times 3.0; v = 2.19$ (m s ⁻¹) $t = \frac{2.19}{3.0}$ C1 $t = 0.73$ (s) A1
Total		5	

Question	Answer	Marks	Guidance
22 (a)	The gradient remains the same	B1	Note: This mark is for the idea that the gradient / slope (of the line) remains the same Allow: The line is (just) shifted (to the right) by the same amount (AW)
(b)	Gradient determined from Fig. 22 <u>and</u> gradient = 16 gradient = 2a ($F = ma$); $F = 920 \times 8.0$ $F = 7.4 \times 10^3$ (N)	C1 C1 A1	Allow ± 0.5 for the value of the gradient Not u^2/x value using the line or a data point because the gradient is not determined Allow this mark even if gradient = a Possible ECF for this A1 mark if the gradient is determined but its value is outside the range 15.5 to 16.5 and the second C1 mark has also been scored Note: The answer to 3 SF is 7360 (N) Note: $F = 920 \times 16 = 14720$ (N) can score the first C1 mark
Total		4	



TOPIC: 3.4.1.2 Moments

SPEC CHECK

Specification	Completed?
Moment of a force about a point. Moment defined as <i>force \times perpendicular distance from the point to the line of action of the force.</i>	
Couple as a pair of equal and opposite coplanar forces. Moment of couple defined as <i>force \times perpendicular distance between the lines of action of the forces.</i>	
Principle of moments.	
Centre of mass. Knowledge that the position of the centre of mass of uniform regular solid is at its centre.	



RECALL

R1. What is a moment?

R2. What name is given to a pair of forces of equal size which act parallel to each other, in opposite directions.

R3. What is the centre of mass of an object?

R4. Where is the centre of mass in a uniform regular solid?

APPLICATIONS

A1. Find the moment provided by a force of 73.1N acting at a perpendicular distance of 0.25m from a pivot.

A2. The diagram shows two children on a see-saw. If the child on the left stays where they are, how far from the pivot should the child on the right sit to balance the see-saw?

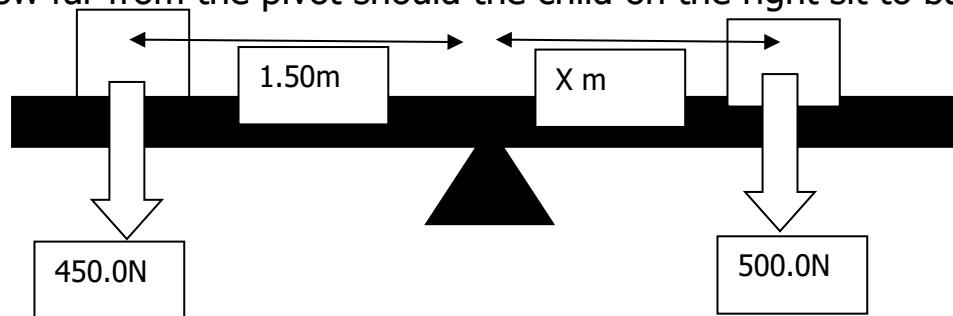

A3. An airtight chamber is kept shut by a release wheel with a diameter of 0.35m. The release wheel will not open unless a moment of at least 50.0Nm is applied across it. What is the minimum force needed to open the chamber door?

A4. The diagram below shows a loaded trailer of mass 24000 kg.

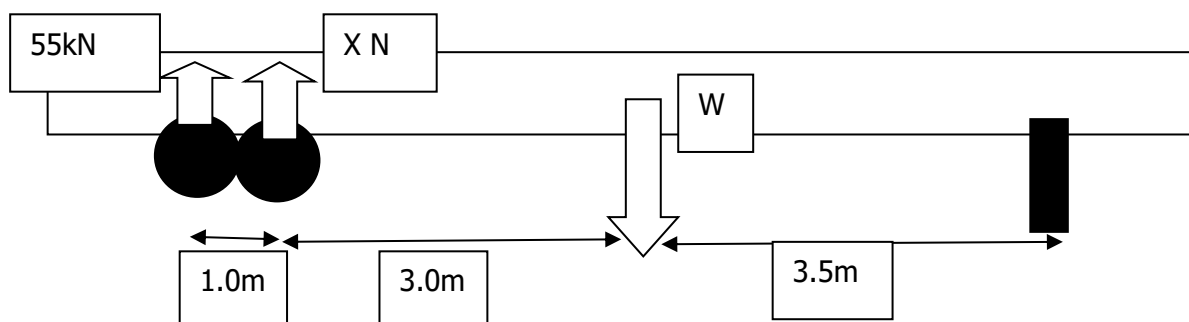

A4.1 Calculate the moment of the wagon's weight about the support.

A4.2 Calculate the upward force X acting on the right hand wheel.



ANSWERS

R1. A moment is the turning effect of a force around a turning point. It is the force \times perpendicular distance from the pivot to the line of action of the force.

R2. These are called a couple.

R3. This is the single point that you can consider its whole weight to act through.

R4. At the centre of the object.

A1. $M = F \times d = 73.1 \times 0.25 = 18.275 = \mathbf{18Nm}$

A2. Anticlockwise moment = $450 \times 1.50 = 675Nm$

Therefore, clockwise moment = $675Nm$

Distance = $M / F = 675 / 500.0 = \mathbf{1.35m}$

A3. $F = M/d = 50.0 / 0.35 = 142.85 = \mathbf{143N}$

A4.1 Weight = $mg = 24000 \times 9.81 = 235\,440N$

$M = F \times d = 235440 \times 3.5 = 824\,040 = \mathbf{820kN}$

A4.2 Clockwise moment about support = $(55,000 \times 7.5) + (X \times 6.5)$
 $= 412,500 + 6.5X$

Anticlockwise moment about support = $824,040$

Anticlockwise moments = Clockwise moments

$412,500 + 6.5X = 824,040$

$X = 63,313,8 = \mathbf{63kN}$



SUPPORT

When two forces act on an object, the object is in equilibrium (at rest or moving at constant velocity) only if the two forces are equal and opposite to each other (**resultant force** = 0). The two forces are said to be **balanced**.

When three forces act on an object, the object is in equilibrium if the resultant force is zero. The resultant force is zero only if the resultant of any two of the forces is equal and opposite to the third force.

When an object is in equilibrium:

The vertical forces are equal in magnitude and opposite in direction, that is, the sum of the upwards forces acting = the sum of downwards forces acting

The horizontal forces are equal in magnitude and opposite in direction, that is, the sum of the forces acting to the left = the sum of forces acting to the right.

The moment of a force about any point is defined as the force multiplied by the perpendicular distance from the line of action of the force to the point:

$$\text{moment of a force} = F \times d$$

The unit of the moment of a force is the newton metre (Nm).

The **principle of moments** states that, considering the moments of the forces about any point, for equilibrium

the sum of the clockwise moments = the sum of the anticlockwise moments

Study the worked examples below as well as those in Chapter 6 *Forces in equilibrium*.

Worked example 1 – one pivot

Question

A child of weight 600 N stands at one end of a 4.0-m-long diving board of weight 200 N. The diving board is supported by a roller at a distance of 1.5 m from the pivot, A, as shown in Figure 1.

By taking moments about A:

Calculate the magnitude of the upward force R exerted by the roller

Calculate the magnitude of the downward force H exerted at A.

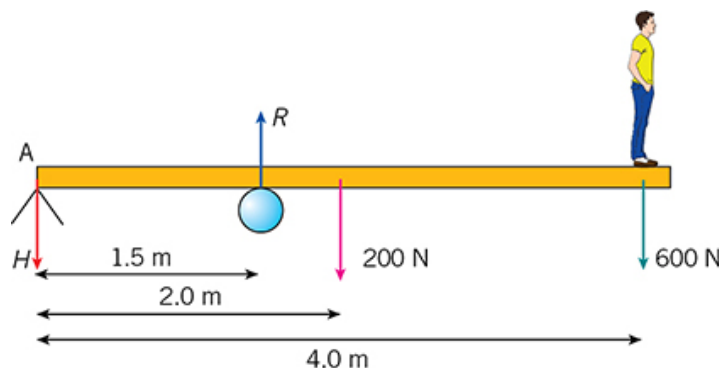
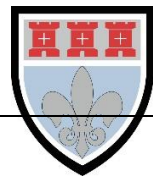

Figure 1

Answer



Step 1

Mark the turning effect of each force on the diagram, using arrows.

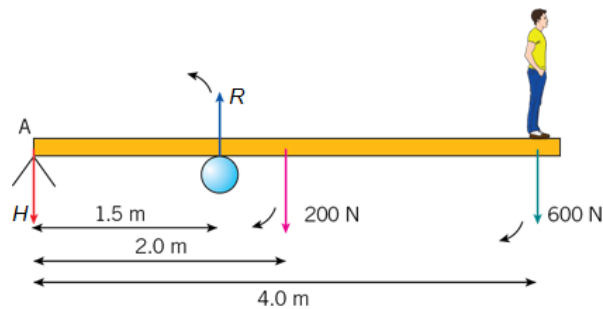

Figure 2 The moment of R is anticlockwise. The moments of the child and the diving board are clockwise. Notice that the weight of the diving board acts at its centre of mass.

Step 2

Calculate all of the moments about A.

Write down the formula:

moment about A = force \times distance from point A

Substitute the values:

clockwise moment of child = (600×4) Nm

clockwise moment of weight of diving board = (200×2) Nm

anticlockwise moment of roller = $(R \times 1.5)$ Nm

Step 3

Apply the principle of moments. 'Take moments' means 'use the principle of moments about A'.

The sum of the clockwise moments = the sum of the anticlockwise moments

$$(600 \times 4) + (200 \times 2) = R \times 1.5$$

$$2400 + 400 = 1.5 R$$

$$2800 = 1.5 R$$

$$R = \frac{2800}{1.5}$$

$$= 1867 \text{ N}$$

$$= 1900 \text{ N}$$

Remember to include units and give your final answer to the minimum number of significant figures quoted in the question – two significant figures in this case.

Step 4

Since the board is in equilibrium:

sum of the upwards forces acting = sum of the downwards forces acting

Substitute values for all of the upwards and downwards forces:

$$1900 - 600 + 200 = H$$

$$H = 1900 - 800 = 1100 \text{ N (two significant figures)}$$

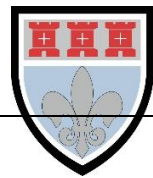

Worked example 2 – two supports

Question

Figure 3 shows a bridge that is supported at both ends A and B. The weight of the bridge is 1100 kN and its length is 20 m. A car of weight 30 kN is 4 m from end B. A bicycle and rider with a combined weight of 800 N are 5 m from end A.

Calculate the magnitude of the upwards support forces P and Q .

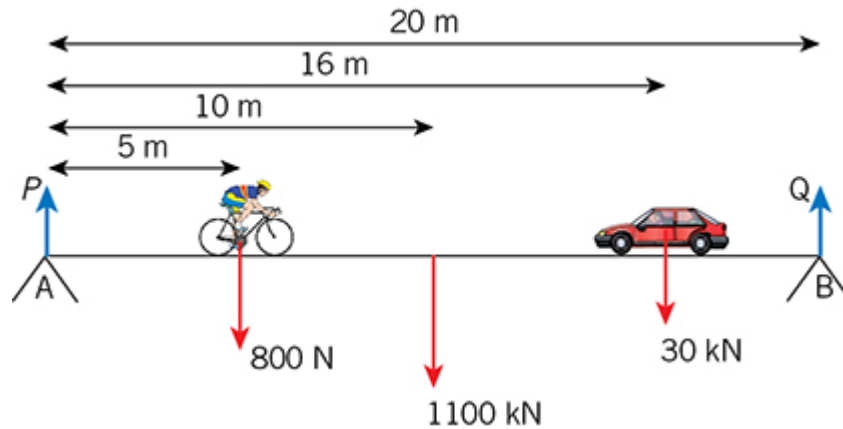

Figure 3

Answer

Step 1

Mark the turning effect of each force on the diagram, using arrows.

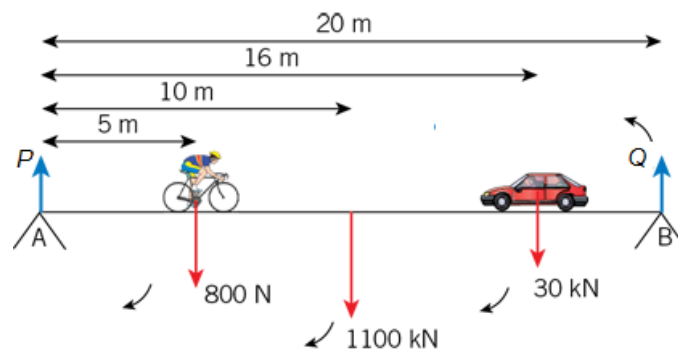

Figure 4

Step 2

Calculate all of the moments about A.

Write down the formula:

moment about A = force \times distance from point A

Substitute the values, converting all forces into newtons:

Clockwise moment of cyclist = (800×5) Nm

Clockwise moment of weight of bridge = $(1.1 \times 10^6 \times 10)$ Nm ($1 \text{ kN} = 1000 \text{ N}$)

Clockwise moment of car = $(3.0 \times 10^4 \times 16)$ Nm

Anticlockwise moment of support B = $(Q \times 20)$ Nm

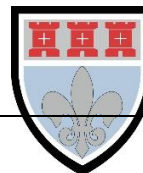
**Step 3**

Apply the principle of moments.

The sum of the clockwise moments = the sum of the anticlockwise moments

$$(800 \times 5) + (1.1 \times 10^6 \times 10) + (3.0 \times 10^4 \times 16) = (Q \times 20)$$

$$4000 + (1.1 \times 10^7) + (48 \times 10^4) = 20 Q$$

$$(0.4 \times 10^4) + (1100 \times 10^4) + (48 \times 10^4) = 20 Q$$

$$(1148.4 \times 10^4) = 20 Q$$

$$Q = \frac{1148.4 \times 10^4}{20}$$

$$Q = 57.42 \times 10^4 \text{ N}$$

$$= 5.7 \times 10^5 \text{ N (two significant figures)}$$

Step 4

Since the bridge is in equilibrium the sum of the upwards forces acting = sum of downwards forces acting.

Substitute values for all of the upwards and downwards forces:

$$(5.74 \times 10^5) + P = (1.10 \times 10^6) + (3.00 \times 10^4) + (8.00 \times 10^2)$$

$$P = (1.1308 \times 10^6) - (5.74 \times 10^5)$$

$$= (11.308 \times 10^5) - (5.74 \times 10^5)$$

$$= 5.568 \times 10^5 \text{ N}$$

$$= 5.6 \times 10^5 \text{ N (two significant figures)}$$

Questions

S1. A child of weight 400 N and another child of weight 300 N play on a seesaw of negligible weight. If the first child sits 2.7 m from the pivot of the seesaw, where must the second child sit to make it balance?

[2 Marks]

.....

.....

.....

.....



S2. A child of weight 500 N sits 2.0 m to the left of the centre of a 5.0-m-long uniform seesaw. The pivot is under the centre of gravity of the seesaw. A friend of weight 300 N sits 2.0 m to the right of the centre. They find that the only way they can balance the seesaw is if someone holds down the right-hand end of the seesaw. Calculate:

S2.1 the moment of the child's weight about the pivot

[2 Marks]

.....
.....
.....

S2.2 the moment of the friend's weight about the pivot

[2 Marks]

.....
.....
.....
.....

S2.3 the downward force that must be applied at the right-hand end of the seesaw.

[2 Marks]

.....
.....
.....
.....

S3. A uniform bridge of weight 5.0×10^4 N is supported on pillars **A** and **B**, which are 20 m apart. A lorry of weight 3.0×10^4 N is stationary 4.0 m from pillar **A**. Find the forces acting on each pillar.

[4 Marks]

.....
.....
.....
.....



Exam-style question

S4. Figure 5 shows a diving board 3 m long with a diver of mass 50 kg at the end.

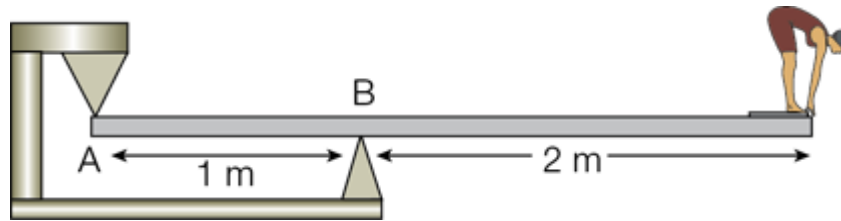

Figure 5

If the weight of the diving board is 200 N calculate:

S4.1 The force at **A**

[2 Marks]

.....

.....

.....

.....

S4.2 The force at **B**.

[2 Marks]

.....

.....

.....

.....

S4.3 Mark the directions of the two forces on the diagram.

[2 Marks]

.....

.....

.....

.....



ANSWERS

Answers here not given to correct number of significant figures to aid checking accuracy in working.

S1. 3.6 m from the pivot (1 mark) on the other side of the seesaw (1 mark)

S2.1 1000 N m (1 mark) anticlockwise (1 mark)

S2.2 600 N m (1 mark) clockwise (1 mark)

S2.3 160 N (2 marks)

S3. A = 49000 N

(1 mark)

= 4.9×10^4 N to two significant figures

(1 mark)

B = 31000 N

(1 mark)

= 3.1×10^4 N to two significant figures

(1 mark)

Exam-style question

S4.1 A = 1.1×10^3 N (1 mark) to two significant figures (1 mark)

S4.2 B = 1.8×10^3 N (1 mark) to two significant figures (1 mark)

S4.3 Award 1 mark for each correct force arrow.



PRACTICAL SKILLS

Complete the following practical skills-based task to improve your experimental understanding of this part of the course in preparation for **Physics Paper 3**.

A1. Convert the following to m^3 :

A1.1 45 cm^3

[1 Mark]

.....
.....

A1.2 120 mm^3 .

[1 Mark]

.....
.....

A2. A gold bar has dimensions $80 \text{ mm} \times 40 \text{ mm} \times 18 \text{ mm}$. The density of gold is 19.3 g cm^{-3} .

A2.1 Calculate the mass of the gold bar in kg.

[1 Mark]

.....
.....

A2.2 If silver has a density of $1.05 \times 10^4 \text{ kg m}^{-3}$, calculate the mass of a silver bar with the same dimensions.

[1 Mark]

.....
.....

A3. The Olmec Heads are thought to at least 2500 years old. The largest discovered so far, the Rancho La Cobata, is 3.4 m high. These heads are carved in basalt, which has a density of $3 \times 10^3 \text{ kg m}^{-3}$. If you approximate the head to a cylinder with a diameter of 3 m, determine the mass of the Rancho La Cobata.

[2 Marks]

.....
.....
.....
.....



A4. In the game of boules, different balls have different masses depending on the player. One of the heavier balls you can buy has a diameter of 80 mm and a mass of 800 g. Calculate the density of the ball in kg m^{-3} .

[2 Marks]

.....

.....

.....

.....

A5. Over 2000 years ago Archimedes was asked by a Greek king to determine if a jeweller had cheated him. The king believed the jeweller had not used all the gold he was given to make a crown – instead he had added some silver. Archimedes placed the crown in water and saw how much water it displaced. He then compared this to a bar of gold equal in mass to that given to the jeweller. Silver has a lower density than gold. How did that fact and the information given above help determine whether the jeweller had cheated the king?

[3 Marks]

.....

.....

.....

.....



ANSWERS

- 1.1** $4.5 \times 10^{-5} \text{ m}^3$ (need to divide by 100 three times). (1 mark)
- 1.2** $1.2 \times 10^{-7} \text{ m}^3$ (need to divide by 1000 three times). (1 mark)
- 2.1** mass = density \times volume = $19.3 \times 8 \times 4 \times 1.8 = 1110 \text{ g} = 1.11 \text{ kg}$. (1 mark)
- 2.2** $m = \rho V = 1.05 \times 10^4 \times (0.08 \times 0.04 \times 0.018) = 0.605 \text{ kg}$. (1 mark)
- 3.** volume of a cylinder = $\pi r^2 h = \pi(1.5)^2 \times 3.4 = 24.0 \text{ m}^3$. (1 mark)
 $m = \rho V = 3 \times 10^3 \times 24 = 7.2 \times 10^4 \text{ kg}$. (1 mark)
- 4.** volume = $\frac{4}{3} \pi r^3 = \frac{4}{3} \pi (40 \times 10^{-3})^3 = 2.68 \times 10^{-4} \text{ m}^3$. (1 mark)
 $\rho = \frac{m}{V} = \frac{0.8}{2.68} \times 10^{-4} = 2990 \text{ kg m}^{-3}$. (1 mark)
- 5.** The crown and the gold bar displaced different amounts of water, which meant the crown was a mixture of silver and gold. To achieve the same mass as pure gold (1 mark) the jeweller had needed a greater volume of silver (1 mark) because it is less dense than gold (1 mark) and in doing so he had increased the volume of the crown.

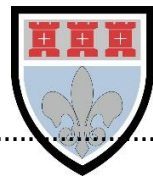

A series of horizontal dotted lines for writing, spanning the width of the page below the header.



MARKING

P	Praise. What were the positive aspects of the work? What did they do well? What skills did they demonstrate?				
I	Improvements. What were the literacy issues in the piece of work?	<i>Write in ink.</i>	<i>Draw in Pencil.</i>	<i>Use a ruler.</i>	
	Always use capital letters at the beginning of a sentence.	Learn the spellings identified in your work.			
	Always use capital letters for proper nouns.	Ensure sentences make sense.			
	Make sure you write on the line and not above or below it.	Use correct punctuation.			
	Use scientific vocabulary appropriate to the task.	Vary your sentences to demonstrate your understanding.			
D answer		B answer		A* answer	
The object (to be weighed) would be placed on the left (of the pivot) and the counterweight moved (along the beam to the right)...	...until the beam is balanced/level/horizontal...	...the value of the mass would be found by reading from the scale where the counterweight is...	...there is an explanation of how they will ensure that the beam is horizontal. Examples of this could be to use a spirit level or the use of a set square.		
Moment = force x distance from pivot.	Moment = force x perpendicular distance from pivot.		Moment = force x perpendicular distance from the pivot to the line of action of the force.		
The mass to be weighed and the counterweight create moments...	...the mass to be weighed creates an anticlockwise moment and the counterweight creates a clockwise moment...		...the clockwise moment increases as the counterweight is moved away from the pivot. ...when the moments are equal the beam will be balanced.		
Calibration is explained as using known masses or weights (placed on the left of the pivot)...	...the value of the mass is written on the scale (right of the pivot)...		...where the counterweight is placed to make the beam balanced/level/horizontal.		
There is a statement that it could be recalibrated by using a heavier counterweight ... (using a longer beam earns this but no higher)	...the change mentioned is explained in terms of creating a greater moment...		...because the object being measured will create a larger moment (owtte).		
There is a general statement that precision is improved by using a smaller scale.	The precision is improved by using small scale divisions (this could be described)...		...and using a thinner string/material to suspend the counterweight with (e.g. wire).		
N	Next Steps. How can they move their work onto the next grade? What didn't they include?			Grade	Effort



TOPIC: 3.4.1.3 Motion Along A Straight Line

SPEC CHECK

Specification	Completed?
Displacement, speed, velocity, acceleration. $v = \frac{\Delta s}{\Delta t}$ $a = \frac{\Delta v}{\Delta t}$ Calculations may include average and instantaneous speeds and velocities.	
Representation by graphical methods of uniform and non-uniform acceleration.	
Significance of areas of velocity–time and acceleration–time graphs and gradients of displacement–time and velocity–time graphs for uniform and non-uniform acceleration e.g. graphs for motion of bouncing ball.	
Equations for uniform acceleration: $v = u + at$ $s = \frac{(u + v)}{2} t$ $s = ut + \frac{at^2}{2}$ $v^2 = u^2 + 2as$ Acceleration due to gravity, g .	
Distinguish between instantaneous velocity and average velocity.	
Measurements and calculations from displacement–time, velocity–time and acceleration–time graphs.	
Calculations involving motion in a straight line.	



RECALL

- R1.** What is the velocity of an object?
- R2.** What is the acceleration of an object?
- R3.** What are the 4 'UVAT' equations for constant acceleration?
- R4.** What kind of motion does a curved displacement-time graph show?
- R5.** What kind of motion does a straight line on a displacement-time graph show?
- R6.** What does the rate of change of gradient on a displacement-time graph represent?
- R7.** What is the difference between average and instantaneous velocity?
- R8.** What does the gradient of a velocity-time graph tell you?
- R9.** How is uniform acceleration shown on a velocity-time graph?
- R10.** What does the area under a velocity-time graph tell you?
- R11.** How is non-uniform acceleration shown on a velocity-time graph?
- R12.** How would you find velocity from an acceleration-time graph?
- R13.** How would constant velocity appear on an acceleration-time graph?
- R14.** What does negative acceleration on an acceleration-time graph show?



ANSWERS

R1. The rate of change of displacement.

R2. The rate of change of velocity.

R3. $v = u + at$
 $S = (u+v)t$
 $S = ut + \frac{1}{2}at^2$
 $v^2 = u^2 + 2as$

R4. Acceleration or deceleration

R5. Constant velocity

R6. Acceleration

R7. Average is the overall displacement divided by the time taken, whilst instantaneous is the velocity at a particular moment in time.

R8. Acceleration

R9. A straight line.

R10. The displacement

R11. A curved line.

R12. The area under the line.

R13. A straight horizontal line through zero on the vertical axis.

R14. This would show deceleration.

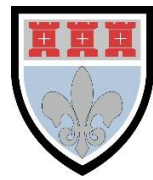

TOPIC: 3.4.1.4 Projectile Motion

SPEC CHECK

Specification	Completed?
Independent effect of motion in horizontal and vertical directions of a uniform gravitational field. Problems will be solvable using the equations of uniform acceleration.	
Qualitative treatment of friction. Distinctions between static and dynamic friction will not be tested.	
Qualitative treatment of lift and drag forces.	
Terminal speed.	
Knowledge that air resistance increases with speed.	
Qualitative understanding of the effect of air resistance on the trajectory of a projectile and on the factors that affect the maximum speed of a vehicle.	
Investigation of the factors that determine the motion of an object through a fluid.	



RECALL

R1. What is freefall motion called when the object is given an initial velocity?

R2. What should you do if you need to use the equations of uniform acceleration on an object that has an initial velocity at an angle to the horizontal?

R3. What is the effect of air resistance on a projectile?

APPLICATIONS

A1. A gun fires a bullet at 502ms^{-1} horizontally. If the gun was held 1.61m above the ground, how far will the bullet travel? Assume there is no air resistance and the ground is horizontal.

A2. A catapult hurls a rock from ground level at 25ms^{-1} , 60.0° to the horizontal. Assuming there is no air resistance and the ground is horizontal.

Calculate

A2.1 The amount of time the rock stays in the air.

A2.2 How far away from the catapult the rock will land.

A3. A golf ball is hit at 12.1 ms^{-2} at angle of 31.5° above the horizontal from a podium 4.20m above the surface of the ground. Calculate the maximum height above the ground reached by the ball.

Assume there is no air resistance and the ground is horizontal.



ANSWERS

R1. Projectile motion.

R2. Resolve the initial velocity into horizontal and vertical components, then use the vertical component to work out how long the object is in the air and how high it goes.

Then use the horizontal component to work out how far it goes in the horizontal direction while it is in the air.

R3. Air resistance causes a drag force which acts in the opposite direction to motion and affects the trajectory of the projectile. The horizontal component of the drag reduces the horizontal speed of the projectile, and reduces the horizontal distance the projectile can travel. If the projectile has a vertical component of velocity, drag reduces the maximum height the projectile will reach and steepens the angle of descent.

A1. $s = 1/2gt^2$

$$t = \sqrt{(2s/g)} = \sqrt{[(2 \times 1.61)/-9.81]} = 0.573s$$

$$s = ut = 502 \times 0.573 = 287.60 = \mathbf{288m}$$

A2.1

Consider the vertical

$$u_v = \sin 60.0 \times 25 = 21.65 \text{ms}^{-1}$$

$$v_v^2 = u_v^2 + 2gs = 21.65^2 + \{2 \times (-9.81) \times 0\}$$

$$v_v = -21.20 \text{ms}^{-1}$$

The negative value comes from the object going towards the ground.

$$t = (v_v - u_v) / a = (-21.65 - 21.20) / -9.81 = 4.413 = \mathbf{4.4 \text{ secs}}$$

A2.2

Consider the horizontal velocity

$$u_h = \cos 60.0 \times 25 = 12.5 \text{ms}^{-1}$$

$$S = u_h t = 12.5 \times 4.413 = 55.174 = \mathbf{55m}$$

A3.

$$\text{Vertical velocity} = u_v = \sin 31.5 \times 12.1 = 6.322 \text{ms}^{-1}$$

At the highest point, the ball's vertical velocity is 0ms^{-1} .

$$v = 0 \text{ms}^{-1}$$

$$a = -9.81 \text{ms}^{-2}$$

$$v^2 = u^2 + 2as$$

$$s = 2.0372 \text{m}$$

$$\text{Total Height Above Ground} = 2.0372 + 4.20 = 6.2372 = \mathbf{6.24m}$$



SUPPORT

Uniform acceleration – *suvat* equations

For an object moving along a straight line at constant acceleration:

- $v = u + at$
- $s = \frac{1}{2}(u + v)t$
- $s = ut + \frac{1}{2}at^2$
- $v^2 = u^2 + 2as$

where s = displacement, u = initial velocity, v = final velocity, a = acceleration, and t = time.

Freefall / object thrown vertically upwards

For a falling object, assuming air resistance is negligible, the only force acting on the object is the force of gravity. The acceleration of the object is constant and is known as the acceleration of freefall, g . Near the Earth's surface g has a value of 9.81 ms^{-2} (this is the value given on the data sheet – you could lose marks in your exam if you approximate this to 10 ms^{-2}).

You can apply the *suvat* equations, given above, to freefall problems where air resistance is negligible and to problems where objects are thrown vertically upwards. As a rule, apply the direction code + for upwards and – for downwards when you substitute values into the *suvat* equations.

For an object thrown vertically upwards:

The velocity of the object at its highest point is 0 ms^{-1}

The time taken for the object to reach its highest point is equal to the time taken for it to fall back down to its starting point.

Projectile motion

A projectile is any object acted upon only by the force of gravity.

The acceleration of the object is always equal to g and always acts downwards. The acceleration only affects the vertical motion of the object.

The horizontal velocity of the object is constant because the acceleration does not have a horizontal component.

The horizontal and vertical motions of the object are independent of each other. When carrying out calculations, be careful not to confuse the values in the horizontal and vertical directions – use the letters 'h' and 'v' as subscripts to indicate whether you are talking about horizontal or vertical motion (e.g., u_h , u_v , a_h , a_v).

Remember, apply the direction code + for upwards and – for downwards when you substitute values into the *suvat* equations.

Worked examples

When you are solving problems relating to uniform motion, freefall, or projectiles:

Write down a list of the values you are given in the question and also the one(s) you have been asked to find.

Choose the most suitable equation and substitute in the values.

If an object is moving at constant velocity then you can use $\text{velocity} = \frac{\text{distance}}{\text{time}}$

If an object is accelerating or decelerating you must use one of the *suvat* equations.

Rearrange the equation, if necessary, and calculate the answer.



Remember to include units and give your answer to the correct number of significant figures and, when appropriate, in standard form.

Worked example 1 – one-stage question

Question

A train moving with an initial velocity of 20 ms^{-1} accelerates uniformly for 20 s at the rate of 1.0 ms^{-2} . Calculate the distance travelled during this time.

Answer

Step 1

Write down the values given in the question.

$$u = 20 \text{ ms}^{-1}$$

$$t = 20 \text{ s}$$

$$a = 1.0 \text{ ms}^{-2}$$

$$s = ? \text{ (distance travelled)}$$

Step 2

Choose the appropriate *suvat* equation.

Since we do not know the final velocity of the train, v , we need to use

$$s = ut + \frac{1}{2} at^2.$$

Step 3

Substitute the values into the equation to find s .

$$s = ut + \frac{1}{2} at^2$$

$$= (20 \times 20) + \frac{1}{2} \times 1.0 \times 20^2$$

$$= 400 + 200$$

$$= 600 \text{ m}$$

$$= 6.0 \times 10^2 \text{ m (to two significant figures)}$$

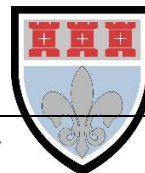

Worked example 2 – multistage question involving gravity

Question

A boy throws a cricket ball vertically upwards with an initial velocity of 20 ms^{-1} .

Assuming that the air resistance acting on the cricket ball is negligible, calculate

2.1 the maximum height the ball reaches

2.2 the time taken for the ball to return to the boy's hand (assuming his hand remains in the same position).

Answer to part a

Step 1

Write down the values for the upward motion of the ball:

$$u = 20 \text{ ms}^{-1}$$

$$v = 0 \text{ ms}^{-1} \text{ (at maximum height the velocity of the ball is zero)}$$

$$a = -g = -9.81 \text{ ms}^{-2} \text{ (acceleration of freefall, gravity acts downwards)}$$

$$s = ? \text{ (maximum height reached)}$$

Step 2

Choose the appropriate *suvat* equation.

Since we do not know the time, t , it takes for the ball to reach its maximum height,

we need to use $v^2 = u^2 + 2as$.

Step 3

Substitute the values into the equation and rearrange to calculate s .

$$v^2 = u^2 + 2as$$

$$0^2 = 20^2 + 2 \times (-9.81) \times s$$

$$0 = 400 - 19.62s$$

$$19.62s = 400 \text{ (rearranging for } s\text{)}$$

$$s = \frac{400}{19.62}$$

$$= 20.39 \text{ m}$$

$$= 20 \text{ m (to two significant figures)}$$

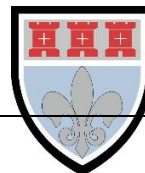
**Answer to part b****Method 1****Step 1**

Write down the values for the whole journey of the ball:

$$u = 20 \text{ ms}^{-1}$$

$$a = -g = -9.8 \text{ m s}^{-2} \text{ (acceleration of freefall, gravity acts downwards)}$$

$$s = 0 \text{ m (overall displacement is zero, since the ball returns to its starting point)}$$

$$t = ? \text{ (time for the whole journey)}$$

Step 2

Choose the appropriate *suvat* equation.

Since we do not know the final velocity of the ball, v , just before it lands in the boy's hand, we need to

$$\text{use } s = ut + \frac{1}{2} at^2.$$

Step 3

Substitute the values into the equation and rearrange to calculate t .

$$s = ut + \frac{1}{2} at^2$$

$$0 = 20t - \frac{1}{2} \times 9.81 \times t^2$$

$$0 = t(20 - \frac{1}{2} \times 9.81 \times t)$$

so

$$t = 0 \text{ (not the solution we are looking for)}$$

or

$$0 = 20 - \frac{1}{2} \times 9.81 \times t$$

$$= 20 - 4.905 t$$

$$t = \frac{20}{4.905}$$

$$= 4.08 \text{ s}$$

$$= 4.1 \text{ s (to two significant figures)}$$

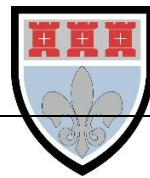
**Method 2****Step 1**

Write down the values.

For the downward journey of the ball:

$$u = 0 \text{ ms}^{-1}$$

$$a = g = 9.81 \text{ ms}^{-2} \text{ (note that this takes downwards as positive)}$$

$$s = 20.39 \text{ m}$$

$$t = ? \text{ (time for the downward journey)}$$

Step 2

Choose the appropriate *suvat* equation.

$$s = ut + \frac{1}{2} at^2$$

Step 3

Substitute the values into the equation and rearrange to calculate t .

$$s = ut + \frac{1}{2} at^2$$

$$20.39 = 0 t + \frac{1}{2} \times 9.81 \times t^2$$

$$= 4.905 t^2$$

$$t^2 = \frac{20.39}{4.905}$$

$$= 4.16 \text{ s}$$

$$t = \sqrt{4.16}$$

$$= 2.04 \text{ s (downwards)}$$

As air resistance is negligible we know the time taken for ball to travel upwards also equals 2.04 s, so:

$$\text{total time in the air} = 2.04 \times 2.04$$

$$= 4.08 \text{ s}$$

$$= 4.1 \text{ s (to two significant figures)}$$



Worked example 3 – multistage question involving projectile motion

Question

A stone is projected horizontally with a velocity of 3.0 ms^{-1} from the top of a vertical cliff 200 m high. Assuming air resistance is negligible, calculate:

- 3.1 how long it takes for the stone to reach the ground
- 3.2 the horizontal distance of the stone from the foot of the cliff when the stone hits the ground
- 3.3 the vertical and horizontal components of the stone's velocity when it hits the ground.

Answer

Step 1

Draw a diagram.

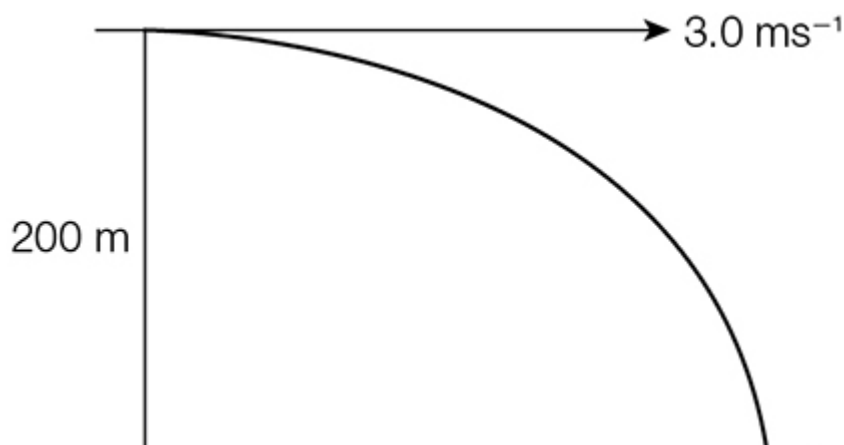

Figure 1

Step 2

Write down a list of values for both the horizontal and vertical directions of motion.

$$u_h = 3.0 \text{ m s}^{-1}$$

$$u_v = 0$$

$$s_h = ? \text{ (part b)}$$

$$s_v = 200 \text{ m}$$

$$a_h = 0$$

$$a_v = g = 9.81 \text{ m s}^{-2} \text{ (note that this takes downwards as positive)}$$

$$t = ? \text{ (part a)}$$

$$v_h = ? \text{ (part c)}$$

$$v_v = ? \text{ (part c)}$$

Step 3

Choose an equation to apply to the vertical direction of motion.

We don't know the final vertical velocity of the stone, so choose $s = ut + \frac{1}{2} at^2$

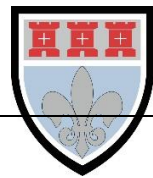
**Step 4**

Substitute the values for vertical motion into the equation and rearrange to find t .

$$s_v = u_v t + \frac{1}{2} a_v t^2$$

$$200 = 0 \times t + \frac{1}{2} \times 9.81 \times t^2$$

$$200 = 4.905 t^2$$

$$t^2 = \frac{200}{4.905}$$

$$= 40.8$$

$$t = \sqrt{40.8}$$

$$= 6.39 \text{ s}$$

$$= 6.4 \text{ s (to two significant figures)}$$

Step 5

In the horizontal direction there is no acceleration, so the horizontal component of the velocity is unchanged:

$$v_h + u_h = 3.0 \text{ ms}^{-1}$$

Apply the equation velocity = $\frac{\text{distance}}{\text{time}}$ to the horizontal motion and rearrange to find the horizontal displacement.

$$v_h = \frac{s_h}{t}$$

$$3.0 = \frac{s_h}{6.39}$$

$$s_h = 3.0 \times 6.39$$

$$= 19.17 \text{ m}$$

$$= 19 \text{ m (to two significant figures)}$$

Step 6

State the horizontal component of the final velocity.

In the horizontal direction there is no acceleration so $v_h = 3.0 \text{ ms}^{-1}$.

Step 7

To calculate the vertical component of the final velocity, choose the appropriate *suvat* equation.

$$v^2 = u^2 + 2as$$

Step 8

Substitute the values for vertical motion into the equation and calculate v_v .

$$v_v^2 = u_v^2 + 2 a_v s_v$$

$$= 0^2 + 2 \times 9.81 \times 200$$

$$= 3924$$

$$v_v = \sqrt{3924}$$

$$= 62.6 \text{ m s}^{-1}$$

$$= 63 \text{ ms}^{-1} \text{ (to two significant figures)}$$



Questions

S1. In an electron gun, an electron is accelerated uniformly from rest to a velocity of $4.0 \times 10^7 \text{ ms}^{-1}$ over a distance of 0.10 m. Calculate the acceleration.

[2 Marks]

.....

.....

.....

.....

S2. A ball starts from rest and rolls down a 1.2-m-long slope with a constant acceleration of 4.9 ms^{-2} . Calculate:

S2.1 how long the ball takes to travel down the slope

[2 Marks]

.....

.....

.....

.....

S2.2 the velocity of the ball when it reaches the bottom of the slope.

[2 Marks]

.....

.....

.....

.....

S3. A train starts from rest and then accelerates at constant acceleration of 1.4 ms^{-2} for 10 s. The train then moves with constant velocity for a further 20 s before the brakes are applied, bringing the train to a stop with a constant deceleration of 2.8 ms^{-2} . Calculate the total distance covered by the train.

[3 Marks]

.....

.....

.....

.....



S4. An object travelling at constant acceleration covers a distance of 14 m in 3.0 s and a further 26 m in the next 3.0 s. Calculate the acceleration.

Hint: write out two equations, one for the first 3 s and one for the total journey.

[3 Marks]

.....

.....

.....

.....

S5. A ball is thrown vertically upwards and reaches its maximum height 2.0 s later.

S5.1 What is the initial velocity of the ball?

[2 Marks]

.....

.....

.....

.....

S5.2 What is the maximum height that the ball reaches?

[2 Marks]

.....

.....

.....

.....

S6. A ball rolls along a 1.0-m-high horizontal table and then falls off of the edge of the table with a horizontal velocity of 4.0 ms^{-1} . Calculate:

S6.1 the time taken for the ball to reach the floor after it leaves the table

[2 Marks]

.....

.....

.....

.....



S6.2 the horizontal distance travelled by the ball during its fall.

[2 Marks]

.....

.....

.....

.....

S7. A bullet is fired horizontally from a gun held 1.4 m above the ground. If the bullet leaves the gun with a velocity of 300 ms^{-1} , at what distance from the gun will the bullet strike the ground?

[3 Marks]

.....

.....

.....

.....

Exam-style question

S8. An aircraft is at rest at one end of a runway with its engine idling. The runway is 2.2 km long. The aircraft then accelerates along the runway with an acceleration of 2.5 ms^{-2} until it reaches its take-off speed of 75 ms^{-1} .

S8.1 Calculate:

The time taken for the aircraft to reach its take-off speed

[2 Marks]

.....

.....

.....

.....

The distance travelled in this time.

[2 Marks]

.....

.....

.....

.....



S8.2 As the aircraft reaches its take-off speed, a warning light alerts the pilot to a possible fault in one of the engines. If the brakes are fully applied the maximum deceleration of the aircraft is 4.0 ms^{-2} . Before the pilot can take any action 2.5 s have already elapsed, during which time the aircraft is continuing to fly at its take-off speed. Determine whether the aircraft can be brought to rest within the remaining length of the runway.

[4 Marks]

.....

.....

.....

.....

.....

.....

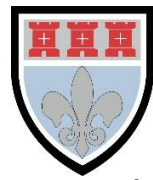
**ANSWERS****S1.** $8.0 \times 10^{15} \text{ ms}^{-2}$ *(2 marks)***S2.1** 0.70 s*(2 marks)***S2.2** 3.4 ms^{-1} to two significant figures (3.43 ms^{-1})*(2 marks)***S3.** section 1 of journey: 70 m

section 2 of journey: 280 m

section 3 of journey: 35 m

total distance = 390 m to two significant figures (385 m)

*(3 marks)***S4.** 1.3 ms^{-2} to two significant figures (1.33 ms^{-2})*(3 marks)***S5.1** 20 ms^{-1} to two significant figures (19.62 ms^{-1})*(2 marks)***S5.1** 20 m to two significant figures (19.62 m)*(2 marks)***S6.1** 0.45 s*(2 marks)***S6.1** 1.8 m*(2 marks)***S7.** ($t = 0.53 \text{ s}$) $s = 160 \text{ m}$ to two significant figures (or $1.6 \times 10^2 \text{ m}$)*(3 marks)***Exam-style question****S8.1** 30 s *(2 marks)*

1.1 km to two significant figures (1125 m) left

*(2 marks)***S8.1** aircraft travels 187.5 m at constant speed

aircraft travels 703 m during deceleration

remaining length of runway from a ii = 1075 m

runway required to stop = $187.5 + 703 = 890.5 \text{ m}$

Yes, there is enough runway left.

(4 marks)



PRACTICAL SKILLS

Complete the following practical skills-based task to improve your experimental understanding of this part of the course in preparation for **Physics Paper 3**.

P1. A student investigates the terminal speed of a ball bearing falling through washing detergent. They decide to investigate how the diameter of the ball bearing affects terminal speed. They use the arrangement shown in **Figure 1**, where the tube is 1 m long and the insulating tape markers are at 20 cm intervals.

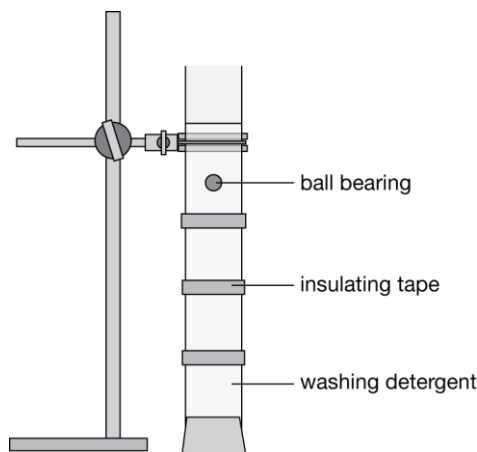

Figure 1 *Experimental set-up*

P1.1 Explain why they are able to use the 20 cm markers to find a value for the terminal speed for each diameter ball bearing.

[3 Marks]

.....

.....

.....

.....

P1.2 State the measurements they would need to take and the most appropriate instruments they should use. In each case state the precision of the instrument.

[6 Marks]

.....

.....

.....

.....

.....

.....

.....



P1.3 What do you think the biggest source of error in their experiment is? Suggest how they could change their method to reduce this error.

[2 Marks]

.....

.....

.....

.....

P1.4 Sketch a speed–time graph for one of the balls falling through the detergent.

[1 Mark]

P2. Sketch a speed–time graph showing the motion of a skydiver as they fall from a plane and then open their parachute.

[3 Marks]

P3. Explain, with reference to Newton's first and second laws, why all objects have a terminal speed.

[3 Marks]

.....

.....

.....

.....

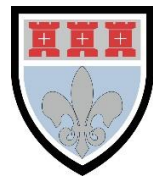

P4. According to legend, Galileo dropped two cannonballs of equal size but different mass from the top of the tower of Pisa to prove Aristotle wrong. Aristotle believed the heavier one would hit the ground first, but Galileo believed they would land at the same time. Who was correct and why?

[4 Marks]

.....

.....

.....

.....

.....

.....

.....



ANSWERS

P1.1 Measure the time for the ball to pass each 20 cm marker

(1 mark)

Find the mean of the time for each 20 cm section

(1 mark)

Use speed = distance / time to find terminal speed

(1 mark)

P1.2 Time using a stopwatch, precision ≈ 0.01 s

(2 marks)

Diameter using a micrometer / vernier calipers, precision ≈ 0.01 mm

(2 marks)

Length using a metre rule, precision ≈ 1 mm

(2 marks)

P1.3 Timing because of human reaction time

(1 mark)

Allow any sensible suggestion, e.g., filming and using frame times to measure time, or light gates to remove error from human reaction time.

(1 mark)

P1.4 See Figure 1

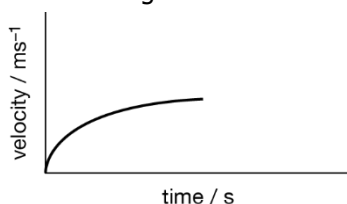

Figure 1 Speed–time graph for ball bearing

P2. See Figure 2.

Graph to show acceleration to terminal velocity.

(1 mark)

Graph to show rapid deceleration as parachute is opened.

(1 mark)

Graph to show new much lower terminal velocity.

(1 mark)

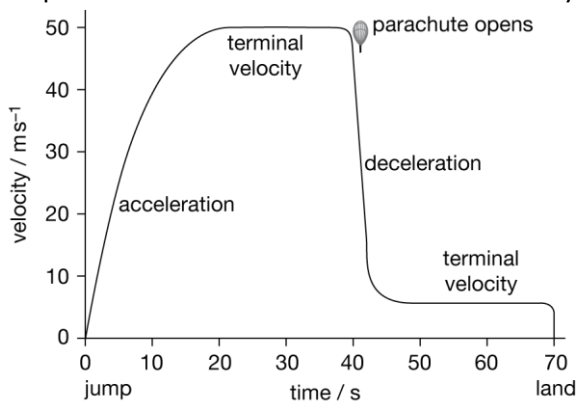

Figure 2 Speed–time graph for skydiver

P3. Initially only weight is acting vertically down so the forces are unbalanced which means the object accelerates (Newton's second law)

(1 mark)

As speed increases, air resistance/drag increases

(1 mark)

Drag increases until equals weight, forces are balanced so the object travels at constant speed (Newton's first law)

(1 mark)

Do not award marks for simply stating Newton's laws, they must be applied to the questions and referenced.

P4. Galileo was correct

(1 mark)

If the cannonballs are identical in size then they will have the same air resistance as they fall.

(1 mark)



The heavier one has a greater weight, $W = mg$, but a greater mass requires a greater force to achieve the same acceleration, $F = ma$, $mg = ma$, or $g = a$. (1 mark)

As they have the same acceleration, they will reach the ground at the same time. (1 mark)



MARKING

P	Praise. What were the positive aspects of the work? What did they do well? What skills did they demonstrate?				
I	Improvements. What were the literacy issues in the piece of work?	<i>Write in ink.</i>		<i>Draw in Pencil.</i>	<i>Use a ruler.</i>
	Always use capital letters at the beginning of a sentence.		Learn the spellings identified in your work.		
	Always use capital letters for proper nouns.		Ensure sentences make sense.		
	Make sure you write on the line and not above or below it.		Use correct punctuation.		
	Use scientific vocabulary appropriate to the task.		Vary your sentences to demonstrate your understanding.		
D answer		B answer		A* answer	
The velocity of A initially increases, becomes constant*...		...until it falls to zero (when it hits the bottom of the container).		*the term 'terminal velocity' is used.	
Weight (allow 'gravity') and drag or oil (water) resistance are correctly identified...		...initially weight is the larger force but drag increases...		...as the speed/velocity increases. ...the weight remains constant.	
Initially there is an overall force downwards...		...the forces then cancel out/become equal...		...the term 'resultant' force is used.	
The ball initially accelerates (due to gravity)the acceleration reduces to zero (as the forces are balanced)the acceleration is given by the gradient of the velocity-time graph.	
The velocity of B initially increases, # becomes constant*until it falls to zero...		# decreases...		...when it hits the oil.	
Weight is initially the larger force, as it hits the oil the drag force increases...		...the drag force will initially be large but will decrease until it equals the weight...		...the term 'resultant' force is used.	
The ball initially accelerates (due to gravity)the acceleration reduces to zero (as the forces are balanced)the acceleration initially is 9.81 (m/s ²).	
The graph drawn has a steeper line rising from the origin which then decreases...		...and comes to rest before steel ball A . The terminal velocity should be greater than Athe area under the graph represents distance so this should be the same in both graphs.	
N	Next Steps. How can they move their work onto the next grade? What didn't they include?			Grade	Effort



CHALLENGE QUESTION

To assess your understanding, answer the following higher-level question on this topic.

- 3 In a hockey match a hockey ball is hit 18.0 m from the front of the goal. The ball leaves the hockey stick with initial velocity v at an angle θ to the horizontal ground. The ball passes over the goal at a maximum height of 2.0 m as shown in Fig. 3.

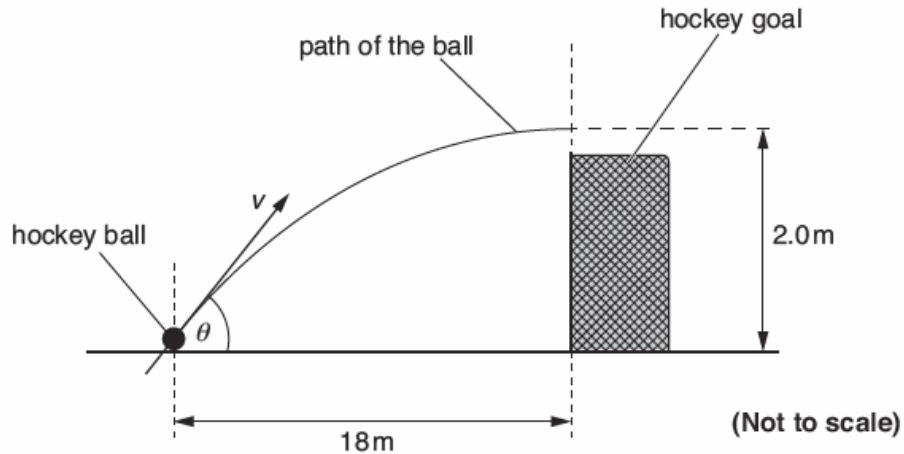

Fig. 3

- (a) The initial vertical component of the velocity of the ball is 6.3 m s^{-1} . Air resistance has negligible effect on the motion of the ball.

- (i) Show that the time t taken for the ball to reach the maximum height is about 0.6 s.

[1]

- (ii) Use the answer to (a)(i) and Fig. 3 to show that the horizontal component of the velocity of the ball as it leaves the hockey stick is about 30 m s^{-1} .

[1]



(iii) Calculate the magnitude of the initial velocity v of the ball.

$$v = \dots\dots\dots \text{ms}^{-1} \quad [2]$$

(b) The hockey ball has a mass of 0.160 kg.

(i) Calculate the initial kinetic energy E_k of the ball as it leaves the hockey stick.

$$E_k = \dots\dots\dots \text{J} \quad [1]$$

(ii) Calculate the change in gravitational potential energy E_p of the ball as it moves from the ground to the maximum height.

$$E_p = \dots\dots\dots \text{J} \quad [1]$$

(iii) Calculate the kinetic energy of the ball at the maximum height.

$$\text{kinetic energy} = \dots\dots\dots \text{J} \quad [1]$$

(c) The hockey ball is replaced with a ball that is affected by air resistance. This ball is hit with the hockey stick so that it leaves the stick with the same initial velocity v .

On Fig. 3 sketch the path the ball is likely to take. [2]



ANSWERS

Question			Answer	Marks	Guidance
3	(a)	(i)	$(t =) \frac{6.3}{9.8(1)}$ $(t =) 0.6(42\dots\text{s})$	M1 A0	Allow other correct methods, e.g: $(t) = \sqrt{\frac{2 \times 2.0}{9.8(1)}}$ or $(t) = \frac{2 \times 2.0}{6.3}$ Not $a = 10 \text{ m s}^{-2}$ Note t must be the unknown
		(ii)	$(v_H =) \frac{18}{0.64}$ or $\frac{18}{0.6}$ $(v_H =) 28 \text{ (m s}^{-1}\text{)} \text{ or } 30 \text{ (m s}^{-1}\text{)}$	M1 A0	Note v must be the unknown
		(iii)	$v = \sqrt{6.3^2 + 30^2}$ $v = 31 \text{ (m s}^{-1}\text{)}$	C1 A1	$v = \sqrt{6.3^2 + 28^2}$ Allow trigonometry methods $v = 29 \text{ (m s}^{-1}\text{)}$ Note 940 scores one mark
(b)	(i)	$(E_k = \frac{1}{2}mv^2 = \frac{1}{2} \times 0.16 \times 30.7^2)$ $E_k = 75 \text{ (J)}$	B1	Possible ECF from (a)(iii)	
	(ii)	$(E_p = mgh = 0.16 \times 9.81 \times 2.0 =) 3.1 \text{ (J)}$	B1	Allow $(E_k = \frac{1}{2}mv^2 = \frac{1}{2} \times 0.16 \times 6.3^2) = 3.2 \text{ (J)}$	
	(iii)	(b)(i) – (b)(ii) ; $(75 - 3.1)$ or $(E_k = \frac{1}{2} \times 0.16 \times 30^2)$ kinetic energy = 72 (J)	B1	Possible ECF from (b)(i) and (b)(ii) Note: Answer is 63 (J) when 28 (m s ⁻¹) is used from (a)(ii)	
(c)		The path is always below the original path	M1		
		The maximum height of path is reached before the front of the hockey goal	A1		
Total				9	



REVISION CHECKLIST

Specification reference	Checklist questions	
3.4.1.1	Can you describe the nature of scalars and vectors, and give examples of each?	<input type="checkbox"/>
3.4.1.1	Can you add vectors by calculation and scale drawing?	<input type="checkbox"/>
3.4.1.1	Can you resolve vectors into two components at right angles to each other, including components of forces along and perpendicular to an inclined plane?	<input type="checkbox"/>
3.4.1.1	Can you solve problems using resolved forces or a closed triangle?	<input type="checkbox"/>
3.4.1.1	Can you describe the conditions for equilibrium for two or three coplanar forces acting at a point?	<input type="checkbox"/>
3.4.1.1	Can you define equilibrium in the context of an object at rest or moving with constant velocity?	<input type="checkbox"/>
3.4.1.2	Can you define the moment of a force about a point as force \times perpendicular distance from the point to the line of action of the force?	<input type="checkbox"/>
3.4.1.2	Can you define a couple as a pair of equal and opposite coplanar forces?	<input type="checkbox"/>
3.4.1.2	Can you define the moment of couple as force \times perpendicular distance between the lines of action of the forces?	<input type="checkbox"/>
3.4.1.2	Can you explain the principle of moments?	<input type="checkbox"/>
3.4.1.2	Can you describe and define centre of mass?	<input type="checkbox"/>
3.4.1.2	Can you explain that the position of the centre of mass of uniform regular solid is at its centre?	<input type="checkbox"/>

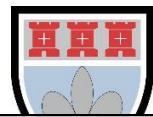

Specification reference	Checklist questions	
3.4.1.3	Can you define displacement, speed, velocity, and acceleration?	<input type="checkbox"/>
3.4.1.3	Can you explain and use the formulae $v = \frac{\Delta s}{\Delta t}$ and $a = \frac{\Delta v}{\Delta t}$?	<input type="checkbox"/>
3.4.1.3	Can you calculate average and instantaneous speeds and velocities?	<input type="checkbox"/>
3.4.1.3	Can you draw a diagram to represent methods of uniform and non-uniform acceleration?	<input type="checkbox"/>
3.4.1.3	Can you explain the significance of areas of velocity–time and acceleration–time graphs, and gradients of displacement–time and velocity–time graphs for uniform and non-uniform acceleration?	<input type="checkbox"/>
3.4.1.3	Can you explain and use the equations for uniform acceleration: $v = u + at$, $s = \left(\frac{u+v}{2}\right)t$, $s = ut + \frac{at^2}{2}$, and $v^2 = u^2 + 2as$?	<input type="checkbox"/>
3.4.1.3	Can you explain acceleration due to gravity, g ?	<input type="checkbox"/>
3.4.1.3	Have you carried out a practical to determine g by a freefall method?	<input type="checkbox"/>
3.4.1.4	Can you explain the independent effect of motion in horizontal and vertical directions of a uniform gravitational field?	<input type="checkbox"/>
3.4.1.4	Can you solve problems using the equations of uniform acceleration?	<input type="checkbox"/>
3.4.1.4	Can you define and explain the effects of friction?	<input type="checkbox"/>
3.4.1.4	Can you explain the effects of lift and drag forces?	<input type="checkbox"/>
3.4.1.4	Can you define and describe terminal speed?	<input type="checkbox"/>
3.4.1.4	Can you explain that air resistance increases with speed?	<input type="checkbox"/>
3.4.1.4	Can you explain the effect of air resistance on the trajectory of a projectile and on the factors that affect the maximum speed of a vehicle?	<input type="checkbox"/>



DATA

DATA

FUNDAMENTAL CONSTANTS AND VALUES

Quantity	Symbol	Value	Units
speed of light in vacuo	c	3.00×10^8	m s^{-1}
permeability of free space	μ_0	$4\pi \times 10^{-7}$	H m^{-1}
permittivity of free space	ϵ_0	8.85×10^{-12}	F m^{-1}
magnitude of the charge of electron	e	1.60×10^{-19}	C
the Planck constant	h	6.63×10^{-34}	J s
gravitational constant	G	6.67×10^{-11}	$\text{N m}^2 \text{kg}^{-2}$
the Avogadro constant	N_A	6.02×10^{23}	mol^{-1}
molar gas constant	R	8.31	$\text{J K}^{-1} \text{mol}^{-1}$
the Boltzmann constant	k	1.38×10^{-23}	J K^{-1}
the Stefan constant	σ	5.67×10^{-8}	$\text{W m}^{-2} \text{K}^{-4}$
the Wien constant	α	2.90×10^{-3}	m K
electron rest mass (equivalent to 5.5×10^{-4} u)	m_e	9.11×10^{-31}	kg
electron charge/mass ratio	$\frac{e}{m_e}$	1.76×10^{11}	C kg^{-1}
proton rest mass (equivalent to 1.00728 u)	m_p	$1.67(3) \times 10^{-27}$	kg
proton charge/mass ratio	$\frac{e}{m_p}$	9.58×10^7	C kg^{-1}
neutron rest mass (equivalent to 1.00867 u)	m_n	$1.67(5) \times 10^{-27}$	kg
gravitational field strength	g	9.81	N kg^{-1}
acceleration due to gravity	g	9.81	m s^{-2}
atomic mass unit (1u is equivalent to 931.3 MeV)	u	1.661×10^{-27}	kg

ASTRONOMICAL DATA

Body	Mass/kg	Mean radius/m
Sun	1.99×10^{30}	6.96×10^8
Earth	5.98×10^{24}	6.37×10^6

GEOMETRICAL EQUATIONS

<i>arc length</i>	$= r\theta$
<i>circumference of circle</i>	$= 2\pi r$
<i>area of circle</i>	$= \pi r^2$
<i>surface area of cylinder</i>	$= 2\pi r h$
<i>area of sphere</i>	$= 4\pi r^2$
<i>volume of sphere</i>	$= \frac{4}{3} \pi r^3$

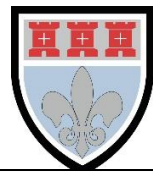

Particle Physics

Class	Name	Symbol	Rest energy/MeV
photon	photon	γ	0
lepton	neutrino	ν_e	0
		ν_μ	0
mesons	electron	e^\pm	0.510999
	muon	μ^\pm	105.659
	π meson	π^\pm	139.576
mesons		π^0	134.972
		K meson	K^\pm
		K^0	497.762
baryons	proton	p	938.257
	neutron	n	939.551

Properties of quarks

antiquarks have opposite signs

Type	Charge	Baryon number	Strangeness
u	$+\frac{2}{3}e$	$+\frac{1}{3}$	0
d	$-\frac{1}{3}e$	$+\frac{1}{3}$	0
s	$-\frac{1}{3}e$	$+\frac{1}{3}$	-1

Properties of Leptons

	Lepton number
Particles: $e^-, \nu_e; \mu^-, \nu_\mu$	+1
Antiparticles: $e^+, \bar{\nu}_e, \mu^+, \bar{\nu}_\mu$	-1

Protons and energy levels

photon energy $E = hf = hc / \lambda$
photoelectricity $hf = \phi + E_{k(\max)}$
energy levels $hf = E_1 - E_2$
de Broglie Wavelength $\lambda = \frac{h}{p} = \frac{h}{mv}$

Waves

wave speed $c = f\lambda$ *period* $f = \frac{1}{T}$
first harmonic $f = \frac{1}{2l} \sqrt{\frac{T}{\mu}}$
fringe spacing $w = \frac{\lambda D}{s}$ *diffraction grating* $d \sin \theta = n\lambda$
refractive index of a substance s, $n = \frac{c}{c_s}$
for two different substances of refractive indices n_1 and n_2
law of refraction $n_1 \sin \theta_1 = n_2 \sin \theta_2$
critical angle $\sin \theta_c = \frac{n_2}{n_1}$ for $n_1 > n_2$

Mechanics

moments *moment* = Fd
velocity and acceleration $v = \frac{\Delta s}{\Delta t}$ $a = \frac{\Delta v}{\Delta t}$
equations of motion $v = u + at$ $s = \left(\frac{u+v}{2}\right)t$
 $v^2 = u^2 + 2as$ $s = ut + \frac{at^2}{2}$
force $F = ma$
force $F = \frac{\Delta(mv)}{\Delta t}$
impulse $F \Delta t = \Delta(mv)$
work, energy and power $W = F s \cos \theta$
 $E_k = \frac{1}{2} m v^2$ $\Delta E_p = mg\Delta h$
 $P = \frac{\Delta W}{\Delta t}$, $P = Fv$
efficiency = $\frac{\text{useful output power}}{\text{input power}}$

Materials

density $\rho = \frac{m}{V}$ Hooke's law $F = k \Delta L$
Young modulus = $\frac{\text{tensile stress}}{\text{tensile strain}}$ *tensile stress* = $\frac{F}{A}$
tensile strain = $\frac{\Delta L}{L}$
energy stored $E = \frac{1}{2} F \Delta L$

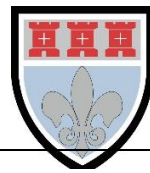

Electricity

current and pd $I = \frac{\Delta Q}{\Delta t}$ $V = \frac{W}{Q}$ $R = \frac{V}{I}$

resistivity $\rho = \frac{RA}{L}$

resistors in series $R_T = R_1 + R_2 + R_3 + \dots$

resistors in parallel $\frac{1}{R_T} = \frac{1}{R_1} + \frac{1}{R_2} + \frac{1}{R_3} + \dots$

power $P = VI = I^2R = \frac{V^2}{R}$

emf $\varepsilon = \frac{E}{Q}$ $\varepsilon = I(R + r)$



Acknowledgements

This document has been produced by Mr J Turnbull.

All relevant information has been credited in the document.

This document has been produced for educational purposes only.

This document has been produced for the AQA A Level Physics Specification.

Student Voice

If you when using this document, you believe there is an improvement to made, please state this in the space below....

Only constructive and reasoned feedback will be considered.