

**ST MARY'S SCIENCE  
DEPARTMENT:  
PHYSICS**

**A LEVEL PHYSICS YEAR 1  
PREPARATORY READING BOOK  
3.5.1: BASICS OF ELECTRICITY  
VOLUME ONE**

**Volume  
One**

<b>NAME</b>	
<b>PHYSICS CLASS</b>	
<b>MODULE TEACHER</b>	
<b>ALPS GRADE</b>	



**THIS MUST  
BE BROUGHT  
TO ALL  
PHYSICS  
LESSONS.**



## Contents

### 3.5.1.1 Basics of Electricity

### 3.5.1.2 Current-Potential Difference Characteristics

### 3.5.1.3 Resistivity

### 3.5.1.4 Circuits

## Overview

This section builds on and develops earlier study of these phenomena from GCSE.

It provides opportunities for the development of practical skills at an early stage in the course and lays the groundwork for later study of the many electrical applications that are important to society.

### **IMPORTANT NOTE**

This booklet, along with the student workbook, must be brought to all Physics lessons with the appropriate teacher.

This booklet may be used as a learning resource in lessons; you are not fully equipped to learn if this is not used in lesson.

This booklet may also be used as a revision resource for intervention, internal assessments and external assessments.

**Please keep this in your student file.**

As part of this course you are expected to **read through this preparatory reading book** and **complete the independent study tasks**.

This work will not be assessed but will be monitored by your class teacher.

This must be completed by the deadline set by your class teacher.



## Definition List

Definitions you must learn for this module.

Key Word	Symbol	Definition
<b>Charge carriers</b>		Charged particles that move through a substance when a pd is applied across it such as electrons.
<b>Circuit rule for current (Kirchhoff's First Law)</b>		<ol style="list-style-type: none"> <li>1. The current passing through two or more components in series is the same through each component.</li> <li>2. At a junction, the total current in = the total current out.</li> </ol>
<b>Circuit rule for pd (Kirchhoff's Second Law)</b>		<ol style="list-style-type: none"> <li>1. For two or more components in series, the total pd across all the components is equal to the sum of the pds across each component.</li> <li>2. The sum of the EMFs round a complete loop in a circuit = the sum of the pds round the loop.</li> </ol>
<b>Current</b>	<b>I</b>	The rate of charge carriers moving in an electrical circuit.
<b>Electromotive force (emf),</b>	<b><math>\epsilon</math></b>	The amount of electrical energy per unit charge produced inside a source of electrical energy.
<b>Ohm's Law</b>		The pd across a metallic conductor is proportional to the current, provided the physical conditions do not change.
<b>Potential Difference</b>	<b>PD</b>	Work done or energy transfer per unit charge between two points when charge moves from one point to another.
<b>Power</b>	<b>P</b>	The rate of transfer of energy.
<b>Resistance</b>	<b>R</b>	The impedance of charge carriers moving in an electrical circuit. = pd/current.
<b>Resistivity</b>	<b><math>\rho</math></b>	Resistance per unit length x area of cross-section. The impedance of current based on the properties of the material only.
<b>Semi-conductor</b>		A substance in which the number of charge carriers increases when the temperature is raised.
<b>Thermistor</b>		Resistor which is designed to have a resistance that changes with temperature.

### IMPORTANT NOTE

These definitions must be memorised by students.

You will be tested on your knowledge of these definitions.



## The Language of Measurement

The following subject specific vocabulary provides definitions of key terms used in the A-level Science specifications.

### **Accuracy**

A measurement result is considered accurate if it is judged to be close to the true value.

### **Calibration**

Marking a scale on a measuring instrument.

This involves establishing the relationship between indications of a measuring instrument and standard or reference quantity values, which must be applied.

For example, placing a thermometer in melting ice to see whether it reads 0 °C, to check if it has been calibrated correctly.

### **Data**

Information, either qualitative or quantitative, that has been collected.

### **Errors**

See also uncertainties.

### **Measurement error**

The difference between a measured value and the true value.

anomalies

These are values in a set of results which are judged not to be part of the variation caused by random uncertainty.

### **Random error**

These cause readings to be spread about the true value, due to results varying in an unpredictable way from one measurement to the next.

Random errors are present when any measurement is made, and cannot be corrected. The effect of random errors can be reduced by making more measurements and calculating a new mean.

### **Systematic error**

These cause readings to differ from the true value by a consistent amount each time a measurement is made.

Sources of systematic error can include the environment, methods of observation or instruments used.

Systematic errors cannot be dealt with by simple repeats. If a systematic error is suspected, the data collection should be repeated using a different technique or a different set of equipment, and the results compared.

### **Zero error**

Any indication that a measuring system gives a false reading when the true value of a measured quantity is zero, e.g. the needle on an ammeter failing to return to zero when no current flows.

A zero error may result in a systematic uncertainty.

### **Evidence**

Data which has been shown to be valid.

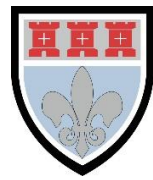
**Fair test**

A fair test is one in which only the independent variable has been allowed to affect the dependent variable.

**Hypothesis**

A proposal intended to explain certain facts or observations.

**Interval**

The quantity between readings, e.g. a set of 11 readings equally spaced over a distance of 1 metre would give an interval of 10 centimetres.

**Precision**

Precise measurements are ones in which there is very little spread about the mean value. Precision depends only on the extent of random errors – it gives no indication of how close results are to the true value.

**Prediction**

A prediction is a statement suggesting what will happen in the future, based on observation, experience or a hypothesis.

**Range**

The maximum and minimum values of the independent or dependent variables; important in ensuring that any pattern is detected.

For example, a range of distances may be quoted as either:

'From 10 cm to 50 cm'

or

'From 50 cm to 10 cm'

**Repeatable**

A measurement is repeatable if the original experimenter repeats the investigation using same method and equipment and obtains the same results.

**Reproducible**

A measurement is reproducible if the investigation is repeated by another person, or by using different equipment or techniques, and the same results are obtained.

**Resolution**

This is the smallest change in the quantity being measured (input) of a measuring instrument that gives a perceptible change in the reading.

**Sketch graph**

A line graph, not necessarily on a grid, that shows the general shape of the relationship between two variables. It will not have any points plotted and although the axes should be labelled they may not be scaled.

**True value**

This is the value that would be obtained in an ideal measurement.

**Uncertainty**

The interval within which the true value can be expected to lie, with a given level of confidence or probability, e.g. "the temperature is  $20\text{ }^{\circ}\text{C} \pm 2\text{ }^{\circ}\text{C}$ , at a level of confidence of 95%.

**Validity**

Suitability of the investigative procedure to answer the question being asked. For example, an investigation to find out if the rate of a chemical reaction depended upon the concentration of one of the reactants would not be a valid procedure if the temperature of the reactants was not controlled.

**Valid conclusion**

A conclusion supported by valid data, obtained from an appropriate experimental design and based on sound reasoning.

**Variables**

These are physical, chemical or biological quantities or characteristics.

**Categoric variables**

Categoric variables have values that are labels. E.g. names of plants or types of material.

**Continuous variables**

Continuous variables can have values (called a quantity) that can be given a magnitude either by counting (as in the case of the number of shrimp) or by measurement (e.g. light intensity, flow rate etc.).

**Control variables**

A control variable is one which may, in addition to the independent variable, affect the outcome of the investigation and therefore must be kept constant or at least monitored.

**Dependent variables**

The dependent variable is the variable of which the value is measured for each change in the independent variable.

**Independent variables**

The independent variable is the variable for which values are changed or selected by the investigator.

**IMPORTANT NOTE**

These definitions must be memorised by students.

You will be tested on your knowledge of these definitions.

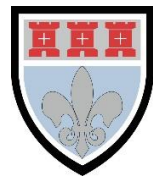

## Equations

The equations below are used in this module.

Quantity/Concept	Equation(s)
<b>Current/Charge</b>	$I = \frac{\Delta Q}{\Delta t}$ $\Delta Q = I \Delta t$
<b>Potential Difference/EMF</b>	$V = PD = \varepsilon = \frac{\Delta W}{\Delta Q}$
<b>Resistance</b>	$R = \frac{V}{I}$
<b>Electrical Power</b>	$P = VI = I^2R = \frac{V^2}{R}$
<b>Electrical Energy Transferred</b>	$E = Vit = \frac{V^2t}{R} = I^2Rt$
<b>Resistivity</b>	$\rho = \frac{RA}{l}$
<b>Cross Sectional Area of Wire</b>	$A = \pi r^2$ <p>This equation is not given in your examination book.</p>

### IMPORTANT NOTE

These equations must be memorised by students.

You will be tested on these equations.

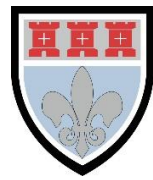

## VIDEO

### COURSE OVERVIEW

To watch a video looking at all of the concepts in electricity, please scan one of the following codes with your smartphone.



**Note**

All rights to this video belong to the creator of the video.

This external third-party content – please check the contents are appropriate.



**Note**

All rights to this video belong to the creator of the video.

This external third-party content – please check the contents are appropriate.

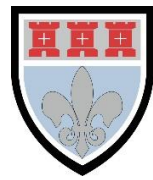

# TOPIC: 3.5.1.1 Basics of Electricity

## SPEC CHECK

Specification	Completed?
Electric current as the rate of flow of charge; potential difference as work done per unit charge.	
$I = \frac{\Delta Q}{\Delta t}$ $V = \frac{W}{Q}$	
Resistance defined as $R = V/I$	
Students can construct circuits from the range of components.	

### Student Checklist

Have I.....	Yes or No?
Read through the notes of this section?	
Highlighted/underlined the key concepts of this section?	
Made my own notes based on the notes of this section?	
Brought the notes to be used in lesson?	

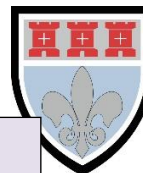

## Definitions

### Prior Knowledge Link

This is a topic found in a previous GCSE module – **Electricity**.

### Current, I

**Electrical current is the rate of flow of charge in a circuit.**

Electrons are the most common charged particles that move around the circuit. The electrical current is the rate of the flow of electrons, not so much the speed but the number of electrons moving in the circuit.

**Examination Hint:** Whilst electrons are the most common type of charge carrier, any particle/molecule which has a charge can be a charge carrier. For example, sodium ions are charged carriers in your body.

If we imagine that electrons are Year 7 students and a wire of a circuit is a corridor, the current is how many students passing in a set time.

**Current is measured in Amperes (or Amps), A**

**Examination Hint:** Memorise this base unit of current.

### Physics Tip

Remember that conventional current flows from + to -, the opposite way from electron flow.

### Physics Tip

When you are doing calculation questions in the exam, do not forget to check your units are correct.

### Charge, Q

The amount of electrical charge is a fundamental concept in the Universe, like mass and length and time. The charge is the ability for an object to interact with an (and produce an) electromagnetic field in the Universe.

At GCSE, you used relative charges to describe particle properties.

There are  $1.60 \times 10^{-19}\text{C}$  in one relative charge.

The charge on one electron is  $-1.60 \times 10^{-19}\text{C}$ .

**Examination Hint:** Memorise the conversion between relative charge and Coulombs.

This means that it takes  $6.25 \times 10^{18}$  electrons to transfer 1C of charge.

**Charge is measured in Coulombs, C**

**Examination Hint:** Memorise this base unit of charge.

### Physics Tip

When a charge flows through a component, it transfers energy to the component (it does work).



## Voltage/Potential Difference/Electromotive Force, V

Voltage is the amount of energy transferred (or work done) per unit charge in a circuit. There are two types of voltage – potential difference (commonly called pd) and electromotive force (commonly called emf).

Potential difference is the work done per unit charge, where work is being done to transfer **energy out** of a circuit. Electromotive force is the work done per unit charge, where work is being done to transfer **energy into** the circuit.

**Examination Hint:** Output devices like bulbs have a potential difference across them. This can be thought of as the energy (potential) drop from before the device compared to after the device.

Power supplies like power packs and batteries have a electromotive force across them. This can be thought as the energy (potential) increases from before the supply compared to after the device.

1 unit of charge is  $6.25 \times 10^{18}$  electrons, so we can think of potential difference as the energy given to each of the electrons, or the pushing force on the electrons.

It is the potential difference that causes a current to flow and we can think of it like water flowing in a pipe. If we make one end higher than the other end, water will flow down in, if we increase the height (increase the potential difference) we get more flowing.

If we think of current as Year 7s walking down a corridor, the harder we push them down the corridor the more we get flowing.

**Examination Hint:** A potential difference will only cause a current when the conductor the potential difference is over is part of a complete circuit.

**Examination Hint:** Memorise this base unit of potential difference.

**Potential Difference is measured in Volts, V**

### Prior Knowledge Link

This is a topic found in a previous GCSE module – **Electricity**.

## Resistance, R

The resistance of a material tells us how easy or difficult it is to make a current flow through it.

If we think of current as Year 7s walking down a corridor, it would be harder to make the Year 7s flow if we added some Year 11 rugby players into the corridor.

Resistance is caused by the charge carriers colliding with objects as they travel down the conductor – this tends to be ions of the conductor itself.

The greater the vibration of particles (temperature increase), the greater the amount of collisions between ions and charge carriers, the greater the resistance.

The more energy per charge the charge carriers have, the greater the amount of collisions between ions and charge carriers, the greater the resistance. Increasing resistance lowers the current.

**Resistance is measured in Ohms,  $\Omega$**

**Examination Hint:** Memorise this base unit of resistance.

### Physics Tip

You could be asked to give the definition of resistance in the exam – make sure you know it.

**Time, t**

You know, time! How long stuff takes and that.

**Time is measured in seconds, s**

**Prior Knowledge Link**

This is a topic found in a previous GCSE module – **Electricity**.

**Equations**

There are three equations that we need to be able to explain and substitute numbers into.

**1**

**Study Tip**

Learn the base units for this equation and the context in which it can be used in.

$$I = \frac{\Delta Q}{\Delta t}$$

**Examination Hint:** This equation is given in the data booklet, however memorising this gives you a better chance of exam success.

This says that the current is the rate of change of charge per second.

This shows current is the rate at which charge flows.

**Study Tip**

Learn what these equations represents.

The shows the current and charge in an electrical circuit.

This can be rearranged into

$$\Delta Q = I\Delta t$$

Which means that the charge is equal to how much current is flowing multiplied by how long it flows for.

**2**

**Study Tip**

Learn the base units for this equation and the context in which it can be used in.

$$V = \frac{E}{Q}$$

**Examination Hint:** This equation is given in the data booklet, however memorising this gives you a better chance of exam success.

This says that the potential difference is equal to the energy per charge.

*The 'push' of the electrons is equal to the energy given to each charge (electron).*

**3**

**Study Tip**

Learn the base units for this equation and the context in which it can be used in.

$$V = IR$$

**Examination Hint:** This equation is given in the data booklet, however memorising this gives you a better chance of exam success.

This says that increasing the p.d. increases the current.

*Increasing the 'push' of the electrons makes more flow.*

It also shows us that for constant V, if R increases I gets smaller.

*Pushing the same strength, if there is more blocking force less current will flow.*

**Study Tip**

Learn what these equations represents.

The shows the different voltages in a circuit.



## Power

Power is a measure of how much work is done (energy is transferred between different stores) in a particular time.

Power is linked to energy by the equation:

$$Power = \frac{Energy}{time}$$

**Examination Hint:** This equation is given in the data booklet, however memorising this gives you a better chance of exam success.

### Study Tip

Learn how to derive the equations and how they link together.

**Power is measured in Watts, W**  
**Energy is measured in Joules, J**  
**Time is measured in seconds, s**

## New Equations for A-Level

### Energy

$V = \frac{E}{Q}$  can be placed into  $E = VQ$  and we know that  $Q = It$  so combining these equations we get a new one to calculate the energy in an electric circuit:

$$E = VQ \leftarrow \dots \dots \dots Q = It$$

so 
$$E = VIt \quad (1)$$

### Study Tip

Learn the base units for these equations and the context in which they can be used in.

**Examination Hint:** This equation is given in the data booklet, however memorising this gives you a better chance of exam success.

### Power

If we look at the top equation, to work out power we divide energy by time:

$$\frac{E}{t} = \frac{VIt}{t}$$

which cancels out to become

$$P = VI \quad (2)$$

If we substitute  $V = IR$  into the last equation, we get another equation for power:

$$P = IV \leftarrow \dots \dots \dots V = IR$$

so 
$$P = I^2 R \quad (3)$$

We can also rearrange  $V = IR$  into  $I = \frac{V}{R}$  and substitute this into  $P = VI$  to get our last equation for power:

$$P = VI \leftarrow \dots \dots \dots I = \frac{V}{R}$$

so 
$$P = \frac{V^2}{R} \quad (4)$$

**Examination Hint:** These equations are given in the data booklet, however memorising them gives you a better chance of exam success.

All equations can be used to answer an exam question; the choice is dependent on the quantities given in the examination question.



## Energy

Two more equations for energy can be derived from equating the equation at the top with equations 3 and 4

Energy = Power x time

$$Pt = I^2 R t$$

Equation 3 becomes

$$E = I^2 R t \quad (5)$$

### Study Tip

Learn the base units for these equations and the context in which they can be used in.

$$Pt = \frac{V^2}{R} t$$

Equation 4 becomes

$$E = \frac{V^2}{R} t \quad (6)$$

**Examination Hint:** These equations are given in the data booklet, however memorising them gives you a better chance of exam success.

All equations can be used to answer an exam question; the choice is dependent on the quantities given in the examination question.

### Physics Tip

You won't be given  $P = E/t$  in the exam, but you will be given  $P = \Delta W/\Delta t$  – so you do not need to remember this equation as long as you remember that work done is the same as energy transferred.

### Study Tip

Learn what these equations represents.

The shows the work done and the power in an electrical circuit.

### Study Tip

Learn how to derive the equations and how they link together.



## VIDEO

To watch a video looking at this concept, please scan one of the following codes with your smartphone.



**Note**

All rights to this video belong to the creator of the video.

This external third-party content – please check the contents are appropriate.



**Note**

All rights to this video belong to the creator of the video.

This external third-party content – please check the contents are appropriate.



# TOPIC: 3.5.1.2 Current-Potential Difference Characteristics

## SPEC CHECK

Specification	Completed?
For an ohmic conductor, semiconductor diode, and filament lamp.	
Ohm's law as a special case where $I \propto V$ under constant physical conditions.	
Unless specifically stated in questions, ammeters and voltmeters should be treated as ideal (having zero and infinite resistance respectively).	
Questions can be set where either $I$ or $V$ is on the horizontal axis of the characteristic graph.	

### Student Checklist

Have I.....	Yes or No?
Read through the notes of this section?	
Highlighted/underlined the key concepts of this section?	
Made my own notes based on the notes of this section?	
Brought the notes to be used in lesson?	

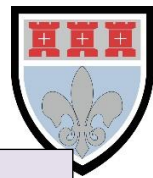

## Ohm's Law

### Prior Knowledge Link

This is a topic found in a previous GCSE module – **Electricity**.

A potential difference causes a current to flow and that the size of the current depends on the size of the potential difference. For something to obey Ohm's law the current flowing is proportional to the potential difference producing it. This only true if the physical conditions remain constant.

**Examination Hint:** Do not forget the physical conditions caveat of Ohm's Law.

As we said  $V=IR$  so this means the resistance is constant.

On a graph of current against potential difference, this appears as a straight line.

### Physics Tip

Anything which is a metallic conductor are ohmic conductors e.g. iron, copper, silver, gold, titanium.

**Examination Hint:** It is a common examination question to define Ohm's law.

The current through a conductor between two points is directly proportional to the potential difference across the two points

(provided the temperature remains constant) (1 mark)

**Examination Hint:** It is a common examination question to state errors made when taking measurements to confirm Ohm's law.

voltmeter position is incorrect because it is across the cell (1 mark)

voltmeter should be connected across the putty (1 mark)

the resistor is not suitable to control the current (1 mark)

pd range is insufficient for experiment (1 mark)



## Taking Measurements

### Prior Knowledge Link

This is a topic found in a previous GCSE module – **Electricity**.

To find how the current through a component varies with the potential difference across it we must take a number of readings.

To measure the potential difference, we use a voltmeter connected in parallel and to measure the current we use an ammeter connected in series.

#### Physics Tip

In the exams, you can assume all voltmeters and ammeters are ideal unless the question tells you otherwise.

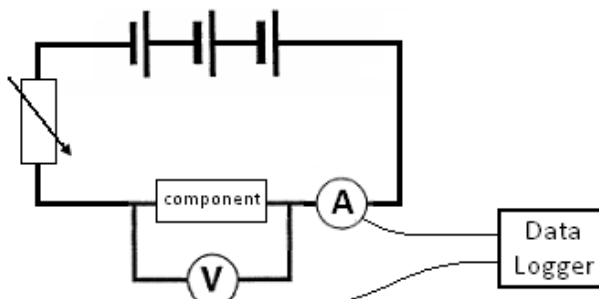

#### Physics Tip

You could use multimeters to measure current and/or voltage.

A multimeter is a measuring instrument that can measure current, voltage or resistance.

If we connect the component to a battery, we would now have one reading for the potential difference and one for the current. But what we require is a *range* of readings.

One way around this would be to use a range of batteries to give different potential differences. A better way is to add a variable resistor to the circuit, this allows us to use one battery and get a range of readings for current and potential difference.

To obtain values for current in the negative direction we can reverse either the battery or the component.

**Examination Hint:** Do not forget to discuss how to achieve a range of results including the negative values.

The greater the range, the more values the relationship is true for.

#### Working Scientifically Link

Remember when to use a potentiometer and when to use a rheostat.

Potentiometers can vary the voltage to zero – rheostats can not do this.

#### Working Scientifically Link

Remember how to remove systematic and random error from measurements.

#### Working Scientifically Link

You must understand how various electrical circuits can be constructed correctly to measure the values wanted.

#### Working Scientifically Link

Remember the ammeter must be in series and the voltmeter in parallel with the component being measured.

#### Working Scientifically Link

The potentiometer must have three outputs if you wish it to alter values in an electrical circuit.



## I-V Graphs

### Prior Knowledge Link

This is a topic found in a previous GCSE module – **Electricity**.

### Key Topic Warning

This topic is very common for questions on previous A-Level Papers.

I-V graphs place the current on the y-axis and the potential difference on the x-axis.

The gradient of the trend line produced is the conductance of the component – how easy it is for the component to allow charger carriers to flow through it.

$$\text{Conductance} = \frac{1}{\text{Resistance}}$$

**Examination Hint:** In examination, you should be able to describe and explain trends in terms of both conductance and resistance.

## Resistor

### Study Tip

Memorise a sketch graph of this trend and explain why this trend is followed.

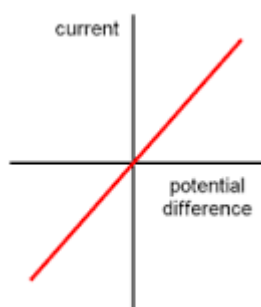

### Physics Tip

I-V curves crop up a lot in exams, so make sure that you really know them.

You could be asked about V-I graphs too.

This shows that when potential difference is zero so is the current. When we increase the potential difference in one direction the current increases in that direction. If we apply a potential difference in the reverse direction a current flows in the reverse direction.

The straight line shows that current is directly proportional to potential difference and it obeys Ohm's law.

The gradient of the line is constant indicating the conductance and resistance is constant.

**Examination Hint:** This graph is only true for a resistor when the physical conditions are kept constant. This is maintained in experiments by only allowing a current to flow when taking a reading.

### Working Scientifically Link

Remember how to numerically prove direct proportionality.

### Working Scientifically Link

Remember how to determine resistance from this graph.



## Filament Lamp

### Study Tip

Memorise a sketch graph of this trend and explain why this trend is followed.

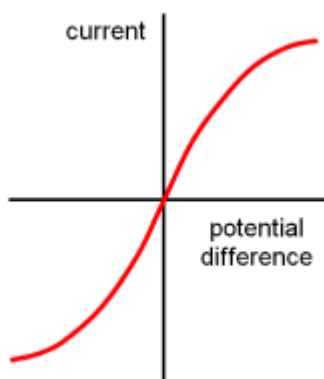

### Physics Tip

The I-V graphs for ohmic conductors and filament lamps can be sketched on V-I graphs – the axes are just swapped over.

Make sure you can draw and recognise these too.

At low values the current is proportional to potential difference and so, obeys Ohm's law.

As the potential difference and current increase so does the temperature, this means it no longer obeys Ohm's law. The increased temperature increase ion vibration, this increases the collisions with the charge carriers.

This increases the resistance and the graph curves, since resistance changes it no longer obeys Ohm's law.

**Examination Hint:** Remember the gradient for the graph shows conductance. The decreasing gradient shows a decreasing conductance and increasing resistance.

**Examination Hint:** It is a common examination question to explain, in terms of electron motion, why the I-V characteristic for the filament lamp is a curve.

An increase in current/voltage leads to an increase in temperature (more heat generated) (1 mark)

This causes an increase in the movement of the lattice/ions/atoms (1 mark)

And therefore, an increase in the rate of collisions with electrons (1 mark)

So, the resistance increases as shown by  $V/I$  changing/ $V$  not proportional to  $I$  (on the graph) (1 mark)

**Examination Hint:** It is a common examination question to explain how the resistance of the lamp varies as the voltage across it is increased from zero to its working voltage.

Resistance increases (1 mark)

Temperature increases (1 mark)

More collisions/interaction of electrons with lattice ions (1 mark)

### Working Scientifically Link

Remember how to determine resistance from this graph.



## Diode

### Study Tip

Memorise a sketch graph of this trend and explain why this trend is followed.

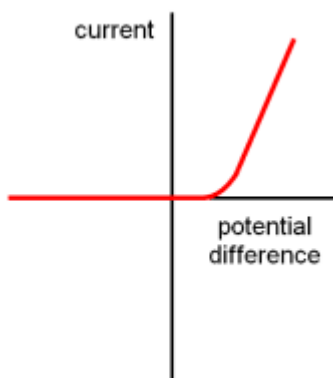

### Examination Tip

You can be asked to determine values using a V-I graph.

However, remember this only determines values for the component being graphed – not the whole circuit.

This shows us that in one direction increasing the potential difference increases the current but in the reverse direction the potential difference does not make a current flow.

We say that it is forward biased.

Since resistance changes it does not obey Ohm's law.

The value of potential difference in the positive direction where current rapidly increases is called the threshold voltage.

**Examination Hint:** Look at the circuit diagrams carefully in questions – is the diode in forward or reverse bias? If it is in reverse bias, no current will flow.

**Examination Hint:** It is a common examination question to explain the limitations of using a variable resistor to collect data for I-V graphs.

Can attain neither maximum nor minimum voltage (1 mark)

Explanation of either maximum OR minimum (1 mark)

**Examination Hint:** It is a common examination question to state how you can experimentally produce a I-V graph for a diode.

Mention of how to vary pd (seen in viable circuit) obtain several readings of I and V with at least 6 different values where the pd does not exceed 1.0V.

Mention of limiting current through diode using protective resistor.

Consider advantage of data logger.

Mention forward bias.

Must include potentiometer.

The following must be included...

means of controlling pd across diode indication of range and frequency of measurement mention of limiting current to avoid damage to diode a consideration of the advantages of a datalogger e.g. many readings, computer display of results use of potential divider instead of series resistor



## Three Special Resistors

### Prior Knowledge Link

This is a topic found in a previous GCSE module – **Electricity**.

### Variable Resistor

A variable resistor is a resistor whose value can be changed.

**Examination Hint:** A rheostat is a two-terminal variable resistor.

A potentiometer is a three-terminal variable resistor.

There are two types of variable resistor which changes the resistance they produce with external conditions. This allows these devices to act as a measure of these external conditions.

Both of these devices are called semi-conductor. Semi-conductors can change the number of free electrons (charge carriers) that become released from their ion lattice structure depending on the conditions. The greater the free electrons in the component, the lower the resistance.

**Examination Hint:** Technically semi-conductor has a double effect since when an electron is released from the structure it leaves a 'positive' hole in the structure travelling in the opposite direction to the negative electron.

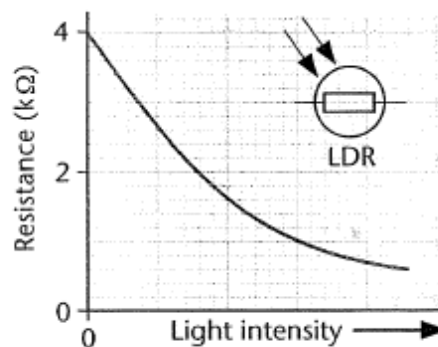
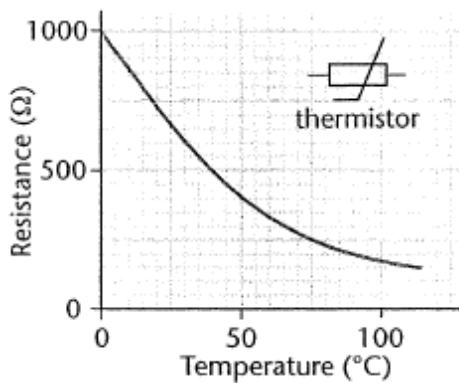

### Study Tip

Memorise a sketch graph of this trend and explain why this trend is followed.

### Study Tip

Memorise how semi-conductors work and how it changes with conditions.

### Thermistor

The resistance of a thermistor varied with temperature.

At low temperatures the resistance is high (few electrons released), at high temperatures the resistance is low (a large number of free electrons released).

**Examination Hint:** It is a common examination question to state and explain what happens to the ammeter reading in a circuit when the temperature of the thermistor increases.

At higher temp, resistance of T is lower (1 mark)

So, circuit resistance is lower, so current/ammeter reading increases (1 mark)

**Examination Hint:** It is a common examination question to state how data have to be obtained so that a graph can be plotted to show how the reading on the voltmeter varies with temperature between 0 °C and 100 °C for a thermistor.

The candidate measures V and temperature.

They have a workable method of varying temperature from 0 °C to 100 °C. They explain why R is necessary and are able to use the thermistor to measure temperature using a graph and calibration curve.

The following should be discussed measurement of V from the voltmeter, use of a thermometer, use of water bath, use of ice, importance of stirring, explanation of the need for series resistor, plotting of a calibration curve, use of calibration curve to determine temperature of room.



---

### **Light Dependant Resistor (L.D.R)**

The resistance of a thermistor varied with light intensity.

In dim light the resistance is high (few electrons released) and in bright light the resistance is low (a large number of free electrons released).

#### **Physics Tip**

A commonly used semiconductor is silicon – many types of electrical components are made from it e.g. diodes.

#### **Physics Tip**

LDRs have a similar resistance curve to thermistors – only it is an increase in light intensity not temperature, which causes the resistance to drop.



## VIDEO

To watch a video looking at this concept, please scan one of the following codes with your smartphone.



**Note**

All rights to this video belong to the creator of the video.

This external third-party content – please check the contents are appropriate.



**Note**

All rights to this video belong to the creator of the video.

This external third-party content – please check the contents are appropriate.



**Note**

All rights to this video belong to the creator of the video.

This external third-party content – please check the contents are appropriate.



## TOPIC: 3.5.1.3 Resistivity

### SPEC CHECK

Specification	Completed?
Resistivity, $\rho = \frac{RA}{L}$	
Description of the qualitative effect of temperature on the resistance of metal conductors and thermistors. Only negative temperature coefficient (ntc) thermistors will be considered.	
Applications of thermistors to include temperature sensors and resistance-temperature graphs.	
Superconductivity as a property of certain materials which have zero resistivity at and below a critical temperature which depends on the material.	
Applications of superconductors to include the production of strong magnetic fields and the reduction of energy loss in transmission of electric power.	
Investigation of the variation of resistance of a thermistor with temperature.	

### Student Checklist

Have I.....	Yes or No?
Read through the notes of this section?	
Highlighted/underlined the key concepts of this section?	
Made my own notes based on the notes of this section?	
Brought the notes to be used in lesson?	

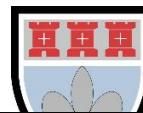

## Resistivity

### Key Topic Warning

This topic is very common for questions on previous A-Level Papers.

The resistance of a wire is caused by free electrons colliding with the positive ions that make up the structure of the metal.

The resistance depends upon several factors:

### Length, $l$

**Length increases – resistance increases**

The longer the piece of wire, the more collisions the charge carriers will have.

### Area, $A$

**Area increases – resistance decreases**

The wider the piece of wire, the more gaps there are between the ions, the fewer charge carrier collisions.

### Temperature

**Temperature increases – resistance increases**

As temperature increases the ions are given more energy and vibrate more, the charge carriers are more likely to collide with the ions.

### Material

The structure of any two metals is similar but not the same, some metal ions are closer together, others have bigger ions. The closer the ions are, the greater the charge carrier collisions.

**Examination Tip:** This makes resistance dependent on the dimensions of the material.

This means there is no absolute value of resistance for a material.

### Physics Tip

Do not confuse resistivity and resistance. Resistance is a property of an object and it depends on the material and dimensions of the object.

Resistivity is a property of a material.

### Study Tip

Learn the base units for this equation and the context in which it can be used in.

$$R = \rho \frac{l}{A}$$

### Study Tip

Learn what this equation represents.

The shows the resistivity of a material.

The resistance of a material can be calculate using

where  $\rho$  is the resistivity of the material.

**Examination Tip:** Questions commonly give the diameter of a material. You must use this to find the area of the material.

**Examination Tip** This equation is given in the data booklet, however memorising this gives you a better chance of exam success.

### Physics Tip

For resistivity calculations, do not forget that you need to have the length in m and the cross-sectional area in  $\text{m}^2$  – you will lose marks if you do not use the correct units.

Resistivity is a factor that accounts for the structure of the metal and the temperature. It is a quantity which does not depend on dimensions – a material will have a constant value for resistivity.



Each metal has its own value of resistivity for each temperature.  
Temperature is the only factor that can the resistivity of a material as it affects resistance.

For example, the resistivity of copper is  $1.7 \times 10^{-8} \Omega\text{m}$  and carbon is  $3 \times 10^{-5} \Omega\text{m}$  at room temperature.

When both are heated to  $100^\circ\text{C}$  their resistivities increase.

**Resistivity is measured in Ohm metres,  $\Omega\text{m}$**

### Physics Tip

Remember the definition of resistivity.

$$\text{Resistivity} = RA / l$$

**Examination Hint:** Do not confuse the unit of resistance with the unit of resistivity.

It is a common question to derive the resistivity units.

## Measuring Resistivity

To measure resistivity of a wire we need to measure the length, cross-sectional area (using  $\text{Area} = \pi r^2$ ) and resistance.

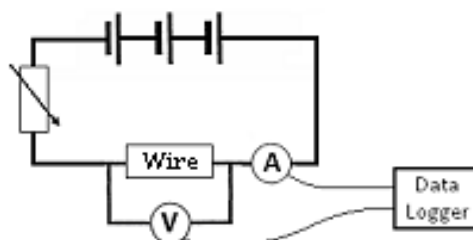

Remember, to measure the resistance we need to measure values of current and potential difference using the set up shown on the right

We then rearrange the equation to  $\rho = \frac{RA}{l}$  and substitute values in

### Physics Tip

It is assumed that the material measured is a wire, therefore the area is equal to  $\pi r^2$ .

**Examination Hint:** Remember that 'l' in the equation is total length – this means that if there are turns on the wire then...

$l = \text{number of turns} \times \text{circumference}$ .

### Working Scientifically Link

Remember when to use a potentiometer and when to use a rheostat.

Potentiometers can vary the voltage to zero – rheostats cannot do this.

### Working Scientifically Link

Remember how to remove systematic and random error from measurements.

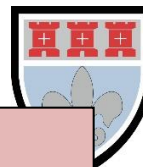

## REQUIRED PRACTICAL RESISTIVITY

### Study Tip

Learn the key skills associated with this practical.

### 1. Calculating Cross-Sectional Area

Measure the diameter of the wire in at least three different places along the wire using a micrometer.

Find the mean diameter and halve it to find the mean radius of the wire. You can assume that the cross-section of the wire is a circle, so you can calculate the cross-sectional area using the area of a circle.

### 2. Measuring Resistivity

1. Attach a flying lead to the end of a test wire and measure the length of the test wire connected in the circuit.
2. Close the switch and measure the current through the circuit and the potential difference across the test wire. Open the switch again once you have taken your measurements and use these values to calculate the resistance of the wire.
3. Repeat this process at least one more time and calculate the mean resistance for this length of wire.
4. Reposition the flying lead and repeat steps 2 and 3 to get an average resistance for a range of different lengths of test wire.
5. Plot a graph of average resistance against length using your results. This should be a straight line through the origin.
6. To find the resistivity you multiply the gradient of the straight line by the cross-sectional area of the wire.

**Examination Hint:** You can assume voltmeters and ammeters are ideal.

**Examination Hint:** A flying lead is a wire with a crocodile clip at the end to allow connection to any point along the test wire.

**Examination Hint:** If the wire heats up, its resistance and resistivity will increase. You can minimise how much it heats up by using a small current and using a switch to make sure current only flows through the wire for short amounts of time, while you are taking measurements.

**Examination Hint:** If you get an anomalous result when you calculate a resistance, you should discount it from calculations for the average resistance. You should also discount any anomalous values when drawing a line of best fit.

**Examination Hint:** The main sources of random errors in this experiment are likely to be the temperature of the wire changing and measuring the length of the wire.

### Study Tip

Learn the required practical process, how to gain accurate results and how the observations can be analysed.



## Superconductivity

The resistivity (and so resistance) of metals increases with the temperature. The reverse is also true that, lowering the temperature lowers the resistivity.

When certain metals are cooled below a **critical temperature** their resistivity drops to zero. The metal now has zero resistance and allows massive currents to flow without losing any energy as heat. These metals are called superconductors. When a superconductor is heated above its critical temperature it loses its superconductivity and behaves like other metals.

The highest recorded temperature to date is  $-196^{\circ}\text{C}$ , large amounts of energy are required to cool the metal to below this temperature.

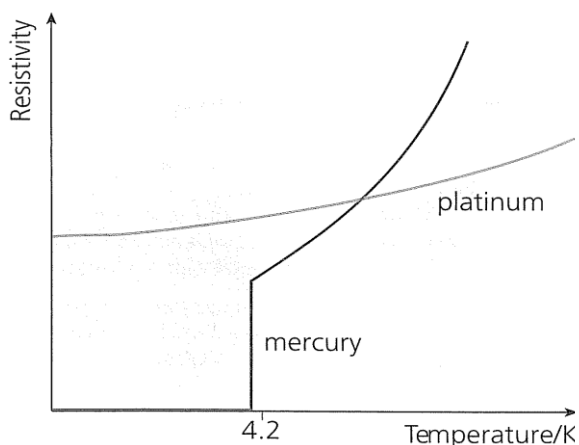

### Study Tip

Memorise a sketch graph of this trend and explain why this trend is followed.

### Physics Tip

A superconductor is a material which has no resistivity.

## Uses of Superconductors

High-power electromagnets

Power cables

Magnetic Resonance Imaging (MRI) scanners

**Examination Hint:** Remember to memorise the definition of critical temperature and why this leads to few superconductors at room temperature.

**Examination Hint:** It is a common examination question to state the significance of the critical temperature of a material.

below the critical temperature/maximum temperature which resistivity/resistance (1 mark)

is zero/becomes superconductor (1 mark).

### Working Scientifically Link

Remember the conditions needed for a superconductor.



## VIDEO

To watch a video looking at this concept, please scan one of the following codes with your smartphone.



**Note**

All rights to this video belong to the creator of the video.

This external third-party content – please check the contents are appropriate.



**Note**

All rights to this video belong to the creator of the video.

This external third-party content – please check the contents are appropriate.



## TOPIC: 3.5.1.4 Circuits

### SPEC CHECK

Specification	Completed?
Resistors: in series, $R_T = R_1 + R_2 + R_3 + \dots$ in parallel, $1/R_T = 1/R_1 + 1/R_2 + 1/R_3 + \dots$	
Energy and power equations: $E = IVt$ ; $P = IV = I^2R = \frac{V^2}{R}$	
The relationships between currents, voltages and resistances in series and parallel circuits, including cells in series and identical cells in parallel.	
Conservation of charge and conservation of energy in dc circuits.	
Students can construct circuits with various component configurations and measure currents and potential differences.	

### Student Checklist

Have I.....	Yes or No?
Read through the notes of this section?	
Highlighted/underlined the key concepts of this section?	
Made my own notes based on the notes of this section?	
Brought the notes to be used in lesson?	



## Series Circuits

### Prior Knowledge Link

This is a topic found in a previous GCSE module – **Electricity**.

In a series circuit, all the components are in one circuit or loop. If resistor 1 in the diagram was removed this would break the whole circuit.

The total current of the circuit is the same at each point in the circuit.

### Study Tip

Learn the base units for these equations and the context in which they can be used in.

$$I_{TOTAL} = I_1 = I_2 = I_3$$

### Physics Tip

This Kirchhoff's 1<sup>st</sup> law – charge cannot be created or destroyed in an electrical circuit.

The total voltage of the circuit is equal to the sum of the p.d.s across each resistor.

$$V_{TOTAL} = V_1 + V_2 + V_3$$

### Study Tip

Learn how these equations link to the electrical circuit laws.

### Physics Tip

This Kirchhoff's 2<sup>nd</sup> law – energy cannot be created or destroyed in an electrical circuit.

The total resistance of the circuit is equal to the sum of the resistance of each resistor.

$$R_{TOTAL} = R_1 + R_2 + R_3$$

**Examination Hint:** These equations are given in the data booklet, however memorising them gives you a better chance of exam success.

All equations can be used to answer an exam question; the choice is dependent on the quantities given in the examination question.

### Physics Tip

Always double check that you have re-arranged equations correctly in the exam – it would be sad to lose marks for making such an easy mistake.

### Study Tip

Learn what these equations represents.

The shows the electrical properties in a series circuit.

### Working Scientifically Link

You must understand how various electrical circuits can be constructed correctly to measure the values wanted.



## Parallel Circuits

### Prior Knowledge Link

This is a topic found in a previous GCSE module – **Electricity**.

Components in parallel have their own separate circuit or loop. If resistor 1 in the diagram was removed this would only break that circuit, a current would still flow through resistors 2 and 3.

The total current is equal to the sum of the currents through each resistor.

$$I_{TOTAL} = I_1 + I_2 + I_3$$

### Physics Tip

This Kirchhoff's 1<sup>st</sup> law – charge cannot be created or destroyed in an electrical circuit.

The total potential difference is equal to the p.d.s across each resistor.

$$V_{TOTAL} = V_1 = V_2 = V_3$$

### Physics Tip

This Kirchhoff's 2<sup>nd</sup> law – energy cannot be created or destroyed in an electrical circuit.

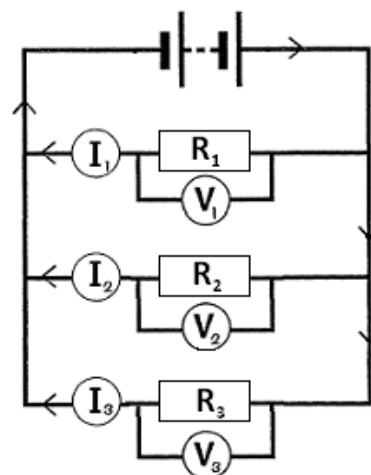

The total resistance can be calculated using the equation:

$$\frac{1}{R_{TOTAL}} = \frac{1}{R_1} + \frac{1}{R_2} + \frac{1}{R_3}$$

### Study Tip

Learn the base units for these equations and the context in which they can be used in.

### Working Scientifically Link

You must understand how various electrical circuits can be constructed correctly to measure the values wanted.

**Examination Hint:** These equations are given in the data booklet, however memorising them gives you a better chance of exam success.

All equations can be used to answer an exam question; the choice is dependent on the quantities given in the examination question.

### Physics Tip

Always double check that you have re-arranged equations correctly in the exam – it would be sad to lose marks for making such an easy mistake.

### Study Tip

Learn what these equations represents.

The shows the electrical properties in a parallel circuit.



## Water Slide Analogy

Imagine instead of getting a potential difference we get a height difference by reaching the top of a slide. This series circuit has three connected slides and the parallel circuit below has three separate slides that reach the bottom.

### Voltages/P.D.s

In series, we can see that the total height loss is equal to how much you fall on slide 1, slide 2 and slide 3 added together. This means that the total p.d. lost must be the p.d. given by the battery. If the resistors have equal values this drop in potential difference will be equal.

In parallel we see each slide will drop by the same height meaning the potential difference is equal to the total potential difference of the battery.

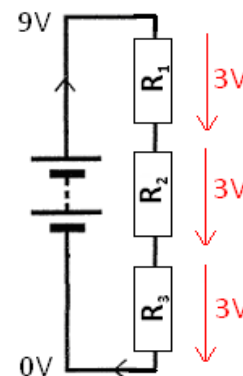

### Currents

If we imagine 100 people on the water slide, in series we can see that 100 people get to the top. All 100 must go down slide 1 then slide 2 and final slide 3, there is no other option.

So, the current in a series circuit is the same everywhere.

In parallel we see there is a choice in the slide we take. 100 people get to the top of the slide but some may go down slide 1, some down slide 2 and some down slide 3. The total number of people is equal to the number of people going down each slide added together, and the total current is equal to the currents in each circuit/loop.

### Physics Tip

You could be asked to draw a circuit diagram in the exam – so make sure you get loads of practice at it before then.

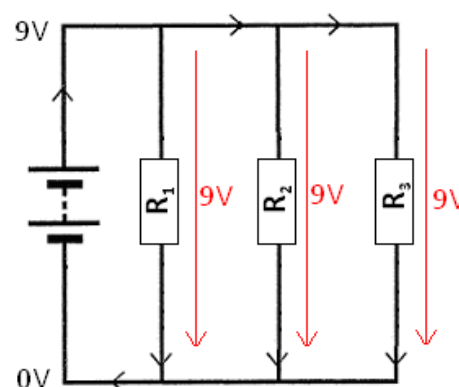

### Physics Tip

A circuit needs to be complete for a current to flow through it.



## VIDEO

To watch a video looking at this concept, please scan one of the following codes with your smartphone.



### Note

All rights to this video belong to the creator of the video.

This external third-party content – please check the contents are appropriate.



### Note

All rights to this video belong to the creator of the video.

This external third-party content – please check the contents are appropriate.

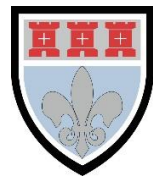

**Note**

All rights to this video belong to the creator of the video.

This external third-party content – please check the contents are appropriate.



## UPGRADE YOUR PHYSICS

The following section include information beyond the A-Level Physics. This information will further your understanding and provide a bridge to University Level Physics.

### 6.3 Circuits – putting it together

In this section, we look at combining resistors, capacitors and inductors in electrical circuits. There are two reasons for doing this. Firstly, once you have left school, you will be faced with complicated electronic networks, and you need to be able to analyse these just as well as the simple series and parallel arrangements you dealt with in the classroom. Secondly, engineers frequently use electric circuits as models or analogies for other systems (say, an oscillating bridge or the control of the nervous system over the muscles in a leg) – the better you understand electric circuits, the better you will understand any linked system.

#### 6.3.1 Circuit Analysis

Our aim here is to be able to solve a circuit like the one below. The circles represent constant-voltage sources (a bit like cells or batteries) and the linked circles represent constant-current sources. Our aim is to find voltage difference across each component, and also to work out the current in each resistor.

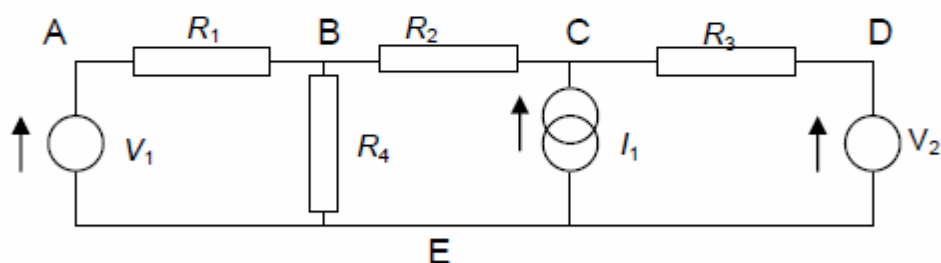

In order to solve the circuit, we use two rules – the Kirchoff Laws. Kirchoff's 1<sup>st</sup> says that the total current going into a junction is equal to the total current leaving it. Therefore, at B in the circuit below, we would say that  $I_{BE} = I_{AB} + I_{CB}$ , where  $I_{BE}$  means the current flowing from B to E (through  $R_4$ ).

Kirchoff's 2<sup>nd</sup> Law is that voltages always add up correctly. In other words, no matter which route we took from E to B, say, we would agree on the voltage difference between E and B. In symbols, if  $V_{BE}$  means



the difference in potential (as measured by a voltmeter) between B and E, then we have  $V_{BE} = V_{AE} + V_{BA}$ . This is basically the same thing as the law of conservation of energy. The voltage (or, more strictly, the *potential*) at B,  $V_B$ , is the energy content of one coulomb of charge at B. In travelling to E, it will lose  $V_B - V_E$  joules, irrespective of the route taken.<sup>23</sup> In fact, we assume the truth of Kirchoff's 2<sup>nd</sup> Law whenever we say, "let's call the voltage at A ' $V_A$ ,'" for we are assuming that the voltage of A does not depend on the route used to measure it.

Using these two rules, and the equation for the current through a resistor (for example,  $V_{BA} = I_{BA} R_1$ ), we may write down a set of equations for the circuit. Notice that because currents are said to go from + to -, this means that if  $V_{AB}$  (the voltage of A, measured relative to B) is positive, then  $V_A$  is bigger than  $V_B$ , and hence  $I_{AB}$  will be positive too. To make the notation easier we will take the potential at E to be zero. In symbolic form, this means that we shall call  $V_{BE}$  (that is,  $V_B - V_E$ )  $V_B$  for short.

Kirchoff's First Law:

$$I_{EA} = I_{AB}; \quad I_{BE} = I_{AB} + I_{CB}; \quad I_1 = I_{CB} + I_{CD}; \quad I_{CD} = I_{DE}$$

Kirchoff's Second Law:

$$\begin{aligned} V_B &= I_{BE} R_4 \\ &= V_A + V_{BA} = V_1 - I_{AB} R_1 \\ &= V_D + V_{CD} + V_{BC} = V_2 + I_{CD} R_3 - I_{CB} R_2 \end{aligned}$$

After elimination, the equations reduce to two:

$$V_1 - I_{AB} R_1 = V_2 + I_1 R_3 - (R_3 + R_2) I_{CB} = (I_{AB} + I_{CB}) R_4,$$

and from these the currents  $I_{AB}$  and  $I_{CB}$  can be found (after a bit of messy algebra). After this, the remaining currents and voltages are straightforward to determine.

These principles can be used to solve any circuit. However, as networks get bigger, it is useful to find more prescriptive methods of solution, which could be used by a computer. We shall cover two methods here – for certain problems, they may be more efficient than the direct application of Kirchoff's Laws.



### 6.3.1.1 Method of Superposition

The method of superposition relies on the fact that for a simple resistor, the current is proportional to the voltage. It follows that if current  $I_1$  causes a voltage difference of 3V, and current  $I_2$  causes a voltage difference of 5V, then current  $I_1+I_2$  will cause an 8V p.d. across the component. Here is the procedure:

- Choose one of the supply components.
- Remove the other supply components from the circuit. Replace voltage sources with direct connections (short circuits), and leave breaks in the circuit where the current sources were (open circuits).
- Calculate the current in each wire, and the voltage across each component.
- Repeat the procedure for each supply component in turn.
- The current in each wire for the original (whole) circuit is equal to the sum of the currents in that wire due to each supply unit.
- The voltage across each component in the original (whole) circuit is equal to the sum of the voltages across that component due to each supply unit.

Let's use this method to analyse the circuit above. We start by considering only source  $V_1$ . Removing the other supply components gives us a circuit like this.

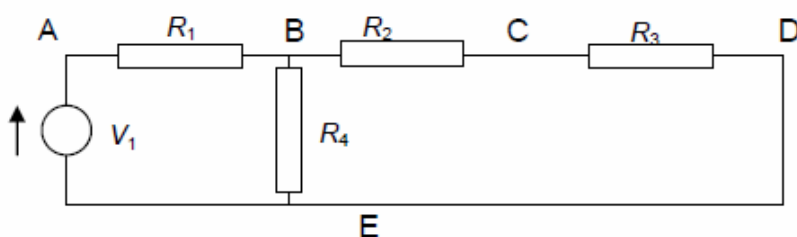

This circuit is easier to analyse as it only has one supply. Supply  $V_1$  feeds a circuit with resistance

$$R_1 + \{R_4 // (R_2 + R_3)\}$$

$$= R_1 + \frac{R_4 (R_2 + R_3)}{R_4 + R_2 + R_3}$$

where // means 'in parallel with.' Accordingly, the current supplied by  $V_1$  (and the current through  $R_1$  which is in series with it) is equal to  $V_1$  divided by this resistance. The voltages of points B, C and D can be calculated, as can the current in each wire. We make a note of the values, and add to them the results of analyses of circuits only containing  $I_1$  and only containing  $V_2$ .



You may find this method good in the sense that you only have to deal with one supply component at a time – and therefore all you need to know is how to combine resistors (something you've done before). Having said that, we end up analysing three circuits rather than one, so it is more time consuming.

Before leaving the method, you may be curious why voltage sources were replaced with short circuits, and current sources with open circuits. Here's the reason. A voltage source does not change the voltage across its terminals, no matter what the current is ( $d \text{ Voltage} / d \text{ Current} = R_{\text{equivalent}} = 0$ ). The only type of resistor which behaves likewise is a perfect conductor ( $0\Omega$ ). Similarly, a current source does not change its current, no matter what the voltage ( $d \text{ Current} / d \text{ Voltage} = 1 / R_{\text{equivalent}} = 0$ ). The equivalent resistor in this case is a perfect insulator ( $\infty\Omega$ ) which lets no current through ever.

### 6.3.1.2 Method of Loop Currents

Here we break the circuit down into the smallest loops it contains. Here there are three loops:

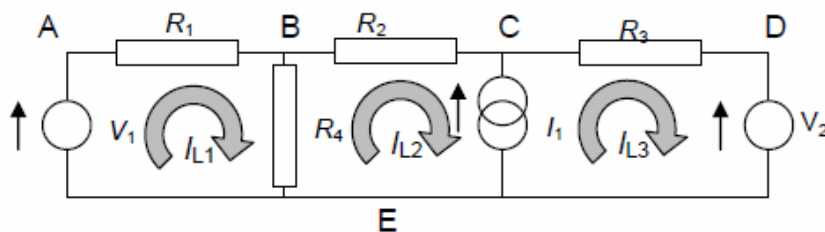

- E to A to B and back to E (loop 1),
- E to B to C to E (loop 2), and
- E to C to D to E (loop 3).

We call the current in loop 1 "loop current" number one ( $I_{L1}$ ), with  $I_{L2}$  and  $I_{L3}$  representing the currents in the other two loops. We then express all other currents in terms of the loop currents. Clearly,  $I_{AB} = I_{L1}$ , since  $R_1$  is in the first loop alone. Similarly,  $I_{BC} = I_{L2}$ , and  $I_{CD} = I_{L3}$ .

The current through  $R_4$  is more complex, since this resistor is part of two of the loops. We write  $I_{BE} = I_{L1} - I_{L2}$ . Here  $I_{L1}$  is positive, since  $I_{BE}$  is in the same direction as  $I_{L1}$ , whereas  $I_{L2}$  (which goes from E to B then on to C) is in the opposite direction. These designations automatically take care of Kirchoff's First Law. Notice that by this method,  $I_1 = I_{L3} - I_{L2}$ .

Each loop now contributes one equation – Kirchoff's 2<sup>nd</sup> law around that loop. Clearly, if you go all the way round the loop, you must return to the voltage you started with. Taking the first loop as an example, we have:

$$0 = V_{AE} + V_{BA} + V_{EB}$$



$$\begin{aligned} &= V_1 - I_{AB} R_1 - I_{BE} R_4 \\ &= V_1 - I_{L1} R_1 + (I_{L1} - I_{L2}) R_4. \end{aligned}$$

In a similar way, we write equations for each of the other two loops<sup>24</sup>. We then have three equations in three unknowns (the three loop currents), which can be solved. The end result is the same as for a direct 'sledgehammer' approach with Kirchoff's Laws – but the method is more organized.



# REVISION CHECKLIST

Specification reference	Checklist questions	
3.5.1.1	Can you explain electric current as the rate of flow of charge?	<input type="checkbox"/>
3.5.1.1	Can you explain potential difference as work done per unit charge?	<input type="checkbox"/>
3.5.1.1	Can you use the formulae $I = \frac{\Delta Q}{\Delta t}$ and $V = \frac{W}{Q}$ ?	<input type="checkbox"/>
3.5.1.1	Can you define resistance as $R = \frac{V}{I}$ ?	<input type="checkbox"/>
3.5.1.2	Can you recognise and use ohmic conductors, semiconductor diodes, and filament lamps?	<input type="checkbox"/>
3.5.1.2	Can you explain Ohm's law as a special case where $I \propto V$ under constant physical conditions?	<input type="checkbox"/>
3.5.1.2	Can you interpret characteristic graphs where $I$ or $V$ is on the horizontal axis?	<input type="checkbox"/>
3.5.1.3	Can you explain resistivity and use the equation $\rho = \frac{RA}{L}$ ?	<input type="checkbox"/>
3.5.1.3	Can you describe the effect of temperature on the resistance of metal conductors and thermistors?	<input type="checkbox"/>
3.5.1.3	Can you describe application of thermistors as temperature sensors?	<input type="checkbox"/>
3.5.1.3	Can you describe and sketch how resistance varies with temperature for a metal wire and for a thermistor?	<input type="checkbox"/>
3.5.1.3	Can you describe superconductivity as a property of certain materials that have zero resistivity at/below a critical temperature which depends on the material?	<input type="checkbox"/>
3.5.1.3	Can you describe some applications of superconductors, including their use in the production of strong magnetic fields and the reduction of energy loss in transmission of electric power?	<input type="checkbox"/>
3.5.1.3	Have you carried out a practical to determine resistivity of a wire using a micrometer, ammeter, and voltmeter?	<input type="checkbox"/>

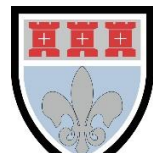

## DATASHEET

## DATA - FUNDAMENTAL CONSTANTS AND VALUES

Quantity	Symbol	Value	Units
speed of light in vacuo	$c$	$3.00 \times 10^8$	$\text{m s}^{-1}$
permeability of free space	$\mu_0$	$4\pi \times 10^{-7}$	$\text{H m}^{-1}$
permittivity of free space	$\epsilon_0$	$8.85 \times 10^{-12}$	$\text{F m}^{-1}$
magnitude of the charge of electron	$e$	$1.60 \times 10^{-19}$	C
the Planck constant	$h$	$6.63 \times 10^{-34}$	J s
gravitational constant	$G$	$6.67 \times 10^{-11}$	$\text{N m}^2 \text{kg}^{-2}$
the Avogadro constant	$N_A$	$6.02 \times 10^{23}$	$\text{mol}^{-1}$
molar gas constant	$R$	8.31	$\text{J K}^{-1} \text{mol}^{-1}$
the Boltzmann constant	$k$	$1.38 \times 10^{-23}$	$\text{J K}^{-1}$
the Stefan constant	$\sigma$	$5.67 \times 10^{-8}$	$\text{W m}^{-2} \text{K}^{-4}$
the Wien constant	$\alpha$	$2.90 \times 10^{-3}$	m K
electron rest mass (equivalent to $5.5 \times 10^{-4}$ u)	$m_e$	$9.11 \times 10^{-31}$	kg
electron charge/mass ratio	$\frac{e}{m_e}$	$1.76 \times 10^{11}$	$\text{C kg}^{-1}$
proton rest mass (equivalent to 1.00728 u)	$m_p$	$1.67(3) \times 10^{-27}$	kg
proton charge/mass ratio	$\frac{e}{m_p}$	$9.58 \times 10^7$	$\text{C kg}^{-1}$
neutron rest mass (equivalent to 1.00867 u)	$m_n$	$1.67(5) \times 10^{-27}$	kg
gravitational field strength	$g$	9.81	$\text{N kg}^{-1}$
acceleration due to gravity	$g$	9.81	$\text{m s}^{-2}$
atomic mass unit (1u is equivalent to 931.5 MeV)	u	$1.661 \times 10^{-27}$	kg

## ALGEBRAIC EQUATION

quadratic equation  $x = \frac{-b \pm \sqrt{b^2 - 4ac}}{2a}$

## ASTRONOMICAL DATA

Body	Mass/kg	Mean radius/m
Sun	$1.99 \times 10^{30}$	$6.96 \times 10^8$
Earth	$5.97 \times 10^{24}$	$6.37 \times 10^6$

## GEOMETRICAL EQUATIONS

arc length =  $r\theta$

circumference of circle =  $2\pi r$

area of circle =  $\pi r^2$

curved surface area of cylinder =  $2\pi r h$

area of sphere =  $4\pi r^2$

volume of sphere =  $\frac{4}{3}\pi r^3$



### Particle Physics

Class	Name	Symbol	Rest energy/MeV
photon	photon	$\gamma$	0
lepton	neutrino	$\nu_e$	0
		$\nu_\mu$	0
	electron	$e^\pm$	0.510999
	muon	$\mu^\pm$	105.659
mesons	$\pi$ meson	$\pi^\pm$	139.576
		$\pi^0$	134.972
	K meson	$K^\pm$	493.821
		$K^0$	497.762
baryons	proton	p	938.257
	neutron	n	939.551

### Properties of quarks

antiquarks have opposite signs

Type	Charge	Baryon number	Strangeness
<b>u</b>	$+\frac{2}{3}e$	$+\frac{1}{3}$	0
<b>d</b>	$-\frac{1}{3}e$	$+\frac{1}{3}$	0
<b>s</b>	$-\frac{1}{3}e$	$+\frac{1}{3}$	-1

### Properties of Leptons

		Lepton number
Particles:	$e^-, \nu_e; \mu^-, \nu_\mu$	+1
Antiparticles:	$e^+, \bar{\nu}_e, \mu^+, \bar{\nu}_\mu$	-1

### Photons and energy levels

*photon energy*  $E = hf = hc / \lambda$   
*photoelectricity*  $hf = \phi + E_{k(\max)}$   
*energy levels*  $hf = E_1 - E_2$   
*de Broglie wavelength*  $\lambda = \frac{h}{p} = \frac{h}{mv}$

### Waves

*wave speed*  $c = f\lambda$     *period*  $f = \frac{1}{T}$   
*first harmonic*  $f = \frac{1}{2l} \sqrt{\frac{T}{\mu}}$   
*fringe spacing*  $w = \frac{\lambda D}{s}$     *diffraction grating*  $d \sin \theta = n\lambda$   
*refractive index of a substance s*,  $n = \frac{c}{c_s}$   
*for two different substances of refractive indices  $n_1$  and  $n_2$ ,*  
*law of refraction*  $n_1 \sin \theta_1 = n_2 \sin \theta_2$   
*critical angle*  $\sin \theta_c = \frac{n_2}{n_1}$  for  $n_1 > n_2$

### Mechanics

*moments*    **moment =  $Fd$**   
*velocity and acceleration*  $v = \frac{\Delta s}{\Delta t}$      $a = \frac{\Delta v}{\Delta t}$   
*equations of motion*  $v = u + at$      $s = \left(\frac{u+v}{2}\right)t$   
 $v^2 = u^2 + 2as$      $s = ut + \frac{at^2}{2}$   
*force*     $F = ma$   
*force*     $F = \frac{\Delta(mv)}{\Delta t}$   
*impulse*     $F \Delta t = \Delta(mv)$   
*work, energy and power*     $W = F s \cos \theta$   
 $E_k = \frac{1}{2} m v^2$      $\Delta E_p = mg\Delta h$   
 $P = \frac{\Delta W}{\Delta t}, P = Fv$   
*efficiency* =  $\frac{\text{useful output power}}{\text{input power}}$

### Materials

*density*  $\rho = \frac{m}{V}$     *Hooke's law*  $F = k \Delta L$   
*Young modulus* =  $\frac{\text{tensile stress}}{\text{tensile strain}}$     *tensile stress* =  $\frac{F}{A}$   
*tensile strain* =  $\frac{\Delta L}{L}$   
*energy stored*  $E = \frac{1}{2} F \Delta L$



## Electricity

current and pd  $I = \frac{\Delta Q}{\Delta t}$   $V = \frac{W}{Q}$   $R = \frac{V}{I}$

resistivity  $\rho = \frac{RA}{L}$

resistors in series  $R_T = R_1 + R_2 + R_3 + \dots$

resistors in parallel  $\frac{1}{R_T} = \frac{1}{R_1} + \frac{1}{R_2} + \frac{1}{R_3} + \dots$

power  $P = VI = I^2R = \frac{V^2}{R}$

emf  $\varepsilon = \frac{E}{Q}$   $\varepsilon = I(R + r)$

## Circular motion

magnitude of angular speed  $\omega = \frac{v}{r}$

$$\omega = 2\pi f$$

centripetal acceleration  $a = \frac{v^2}{r} = \omega^2 r$

centripetal force  $F = \frac{mv^2}{r} = m\omega^2 r$

## Simple harmonic motion

acceleration  $a = -\omega^2 x$

displacement  $x = A \cos(\omega t)$

speed  $v = \pm \omega \sqrt{A^2 - x^2}$

maximum speed  $v_{\max} = \omega A$

maximum acceleration  $a_{\max} = \omega^2 A$

for a mass-spring system  $T = 2\pi \sqrt{\frac{m}{k}}$

for a simple pendulum  $T = 2\pi \sqrt{\frac{l}{g}}$

## Thermal physics

energy to change temperature  $Q = mc\Delta\theta$

energy to change state  $Q = ml$

gas law  $pV = nRT$   
 $pV = NkT$

kinetic theory model  $pV = \frac{1}{3}N m (c_{\text{rms}})^2$

kinetic energy of gas molecule  $\frac{1}{2}m (c_{\text{rms}})^2 = \frac{3}{2}kT = \frac{3RT}{2N_A}$

## Gravitational fields

force between two masses  $F = \frac{Gm_1m_2}{r^2}$

gravitational field strength  $g = \frac{F}{m}$

magnitude of gravitational field strength in a radial field  $g = \frac{GM}{r^2}$

work done  $\Delta W = m\Delta V$

gravitational potential  $V = -\frac{GM}{r}$   
 $g = -\frac{\Delta V}{\Delta r}$

## Electric fields and capacitors

force between two point charges  $F = \frac{1}{4\pi\epsilon_0} \frac{Q_1Q_2}{r^2}$

force on a charge  $F = EQ$

field strength for a uniform field  $E = \frac{V}{d}$

work done  $\Delta W = Q\Delta V$

field strength for a radial field  $E = \frac{1}{4\pi\epsilon_0} \frac{Q}{r^2}$

electric potential  $V = \frac{1}{4\pi\epsilon_0} \frac{Q}{r}$

$$E = \frac{\Delta V}{\Delta r}$$

capacitance  $C = \frac{Q}{V}$

$$C = \frac{A\epsilon_0\epsilon_r}{d}$$

capacitor energy stored  $E = \frac{1}{2}QV = \frac{1}{2}CV^2 = \frac{1}{2} \frac{Q^2}{C}$

capacitor charging  $Q = Q_0(1 - e^{-t/RC})$

decay of charge  $Q = Q_0e^{-t/RC}$

time constant  $RC$



## Magnetic fields

<i>force on a current</i>	$F = BIl$
<i>force on a moving charge</i>	$F = BQv$
<i>magnetic flux</i>	$\Phi = BA$
<i>magnetic flux linkage</i>	$N\Phi = BAN \cos \theta$
<i>magnitude of induced emf</i>	$\varepsilon = N \frac{\Delta\Phi}{\Delta t}$
	$N\Phi = BAN \cos \theta$
<i>emf induced in a rotating coil</i>	$\varepsilon = BAN\omega \sin \omega t$
<i>alternating current</i>	$I_{\text{rms}} = \frac{I_0}{\sqrt{2}} \quad V_{\text{rms}} = \frac{V_0}{\sqrt{2}}$
<i>transformer equations</i>	$\frac{N_s}{N_p} = \frac{V_s}{V_p}$
	$\text{efficiency} = \frac{I_s V_s}{I_p V_p}$

## Nuclear physics

<i>the inverse square law for <math>\gamma</math> radiation</i>	$I = \frac{k}{x^2}$
<i>radioactive decay</i>	$\frac{\Delta N}{\Delta t} = -\lambda N, N = N_0 e^{-\lambda t}$
<i>activity</i>	$A = \lambda N$
<i>half-life</i>	$T_{1/2} = \frac{\ln 2}{\lambda}$
<i>nuclear radius</i>	$R = R_0 A^{1/3}$
<i>energy-mass equation</i>	$E = mc^2$

## OPTIONS

### Astrophysics

1 astronomical unit	$= 1.50 \times 10^{11} \text{ m}$
1 light year	$= 9.46 \times 10^{15} \text{ m}$
1 parsec	$= 206265 \text{ AU} = 3.08 \times 10^{16} \text{ m}$
	$= 3.26 \text{ light year}$

$$\text{Hubble constant, } H = 65 \text{ km s}^{-1} \text{ Mpc}^{-1}$$

$$M = \frac{\text{angle subtended by image at eye}}{\text{angle subtended by object at unaided eye}}$$

<i>in normal adjustment</i>	$M = \frac{f_o}{f_e}$
<i>Rayleigh criterion</i>	$\theta \approx \frac{\lambda}{D}$
<i>magnitude equation</i>	$m - M = 5 \log \frac{d}{10}$
<i>Wien's law</i>	$\lambda_{\text{max}} T = 2.9 \times 10^{-3} \text{ m K}$
<i>Stefan's law</i>	$P = \sigma AT^4$
<i>Schwarzschild radius</i>	$R_s \approx \frac{2GM}{c^2}$
<i>Doppler shift for <math>v \ll c</math></i>	$\frac{\Delta f}{f} = -\frac{\Delta \lambda}{\lambda} = \frac{v}{c}$
<i>red shift</i>	$z = -\frac{v}{c}$
<i>Hubble's law</i>	$v = Hd$

### Medical physics

<i>lens equations</i>	$P = \frac{1}{f}$
	$m = \frac{v}{u}$
	$\frac{1}{f} = \frac{1}{u} + \frac{1}{v}$
<i>threshold of hearing</i>	$I_0 = 1.0 \times 10^{-12} \text{ W m}^{-2}$
<i>intensity level</i>	$\text{intensity level} = 10 \log \frac{I}{I_0}$
<i>absorption</i>	$I = I_0 e^{-\mu x}$
	$\mu_m = \frac{\mu}{\rho}$
<i>ultrasound imaging</i>	$Z = \rho c$
	$\frac{I_r}{I_i} = \left( \frac{Z_2 - Z_1}{Z_2 + Z_1} \right)^2$
<i>half-lives</i>	$\frac{1}{T_E} = \frac{1}{T_B} + \frac{1}{T_P}$



## Engineering physics

*moment of inertia*  $I = \Sigma mr^2$

*angular kinetic energy*  $E_k = \frac{1}{2} I \omega^2$

*equations of angular motion*

$$\omega_2 = \omega_1 + \alpha t$$

$$\omega_2^2 = \omega_1^2 + 2\alpha\theta$$

$$\theta = \omega_1 t + \frac{\alpha t^2}{2}$$

$$\theta = \frac{(\omega_1 + \omega_2) t}{2}$$

*torque*  $T = I \alpha$

$$T = F r$$

*angular momentum*  $\text{angular momentum} = I \omega$

*angular impulse*  $T \Delta t = \Delta(I \omega)$

*work done*  $W = T \theta$

*power*  $P = T \omega$

*thermodynamics*  $Q = \Delta U + W$

$$W = p \Delta V$$

*adiabatic change*  $pV^\gamma = \text{constant}$

*isothermal change*  $pV = \text{constant}$

*heat engines*

$$\text{efficiency} = \frac{W}{Q_H} = \frac{Q_H - Q_C}{Q_H}$$

$$\text{maximum theoretical efficiency} = \frac{T_H - T_C}{T_H}$$

*work done per cycle = area of loop*

*input power = calorific value  $\times$  fuel flow rate*

$$\text{indicated power} = \frac{\text{area of } p - V \text{ loop}}{\text{number of cycles per second}} \times \text{number of cylinders}$$

*output or brake power*  $P = T \omega$

*friction power = indicated power - brake power*

*heat pumps and refrigerators*

*refrigerator:*  $COP_{\text{ref}} = \frac{Q_C}{W} = \frac{Q_C}{Q_H - Q_C}$

*heat pump:*  $COP_{\text{hp}} = \frac{Q_H}{W} = \frac{Q_H}{Q_H - Q_C}$

## Turning points in physics

*electrons in fields*  $F = \frac{eV}{d}$

$$F = Bev$$

$$r = \frac{mv}{Be}$$

$$\frac{1}{2} mv^2 = eV$$

*Millikan's experiment*  $\frac{QV}{d} = mg$

$$F = 6\pi\eta r v$$

*Maxwell's formula*  $c = \frac{1}{\sqrt{\mu_0 \epsilon_0}}$

$$\lambda = \frac{h}{p} = \frac{h}{\sqrt{2meV}}$$

*special relativity*  $t = \frac{t_0}{\sqrt{1 - \frac{v^2}{c^2}}}$

$$l = l_0 \sqrt{1 - \frac{v^2}{c^2}}$$

$$E = m c^2 = \frac{m_0 c^2}{\sqrt{1 - \frac{v^2}{c^2}}}$$

## Electronics

*resonant frequency*  $f_0 = \frac{1}{2\pi \sqrt{LC}}$

*Q-factor*  $Q = \frac{f_0}{f_B}$

*operational amplifiers: open loop*  $V_{\text{out}} = A_{\text{OL}}(V_+ - V_-)$

*inverting amplifier*  $\frac{V_{\text{out}}}{V_{\text{in}}} = -\frac{R_f}{R_{\text{in}}}$

*non-inverting amplifier*  $\frac{V_{\text{out}}}{V_{\text{in}}} = 1 + \frac{R_f}{R_1}$

*summing amplifier*  $V_{\text{out}} = -R_f \left( \frac{V_1}{R_1} + \frac{V_2}{R_2} + \frac{V_3}{R_3} + \dots \right)$

*difference amplifier*  $V_{\text{out}} = (V_+ - V_-) \frac{R_f}{R_1}$

*Bandwidth requirement:*

*for AM*  $\text{bandwidth} = 2f_M$

*for FM*  $\text{bandwidth} = 2(\Delta f + f_M)$

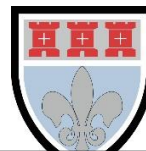

### **Acknowledgements**

This document has been produced by Mr J Turnbull.

All relevant information has been credited in the document.

This document has been produced for educational purposes only.

This document has been produced for the AQA A Level Physics Specification.

### **Student Voice**

If you when using this document, you believe there is an improvement to made, please state this in the space below....

Only constructive and reasoned feedback will be considered.