

- Q1.** Three energy sources used to generate electricity are given in **List A**. Statements about the energy sources used to generate electricity are given in **List B**.

Draw **one** line from each energy source in **List A** to the statement about the energy source in **List B**.

List A Energy source	List B Statement about energy source
Geothermal	Uses energy from falling water
Hydroelectric	Uses energy from inside the Earth
Nuclear	Is unpredictable
	Produces dangerous waste

(Total 3 marks)

- Q2.** (a) The diagrams, **X**, **Y** and **Z**, show how the particles are arranged in the three states of matter.

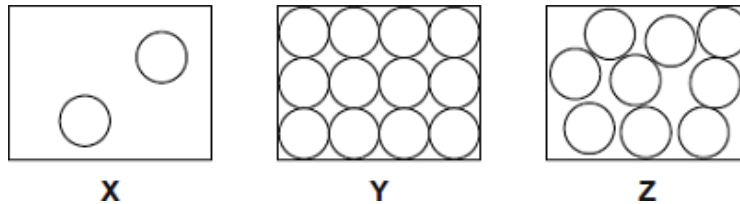

- (i) Which **one** of the diagrams, **X**, **Y** or **Z**, shows the arrangement of particles in a liquid?

Write the correct answer in the box.

(1)

- (ii) Which **one** of the diagrams, **X**, **Y** or **Z**, shows the arrangement of particles in a gas?

Write the correct answer in the box.

(1)

(b) Draw a ring around the correct answer in each box to complete each sentence.

(i) In a gas, the particles are

- vibrating in fixed positions.
- moving randomly.
- not moving.

(1)

(ii) In a solid, the forces between the particles are

- stronger than
- equal to
- weaker than

the forces between

the particles in a liquid.

(1)

(c) The picture shows a puddle of water in a road, after a rain shower.

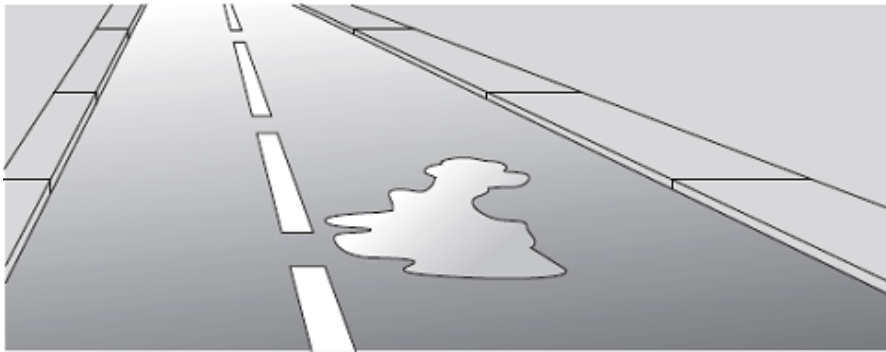

(i) During the day, the puddle of water dries up and disappears. This happens because the water particles move from the puddle into the air.

What process causes water particles to move from the puddle into the air?

Draw a ring around the correct answer.

condensation

evaporation

radiation

(1)

(ii) Describe **one** change in the weather which would cause the puddle of water to dry up faster.

.....
.....

(1)

(Total 6 marks)

- Q3.** (a) A student used the apparatus drawn below to investigate the heating effect of an electric heater.

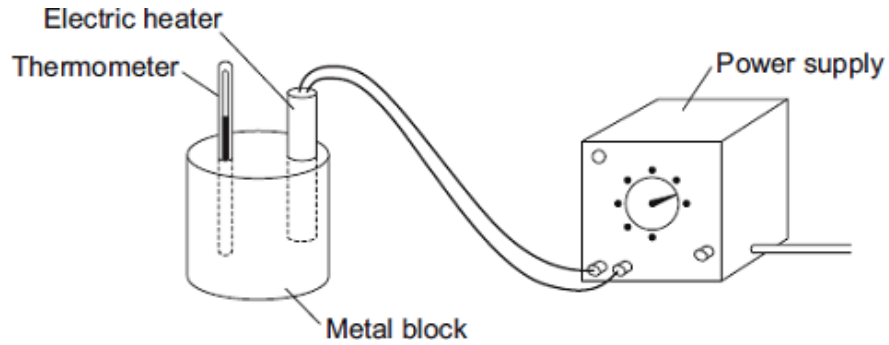

- (i) Before starting the experiment, the student drew **Graph A**.

Graph A shows how the student expected the temperature of the metal block to change after the heater was switched on.

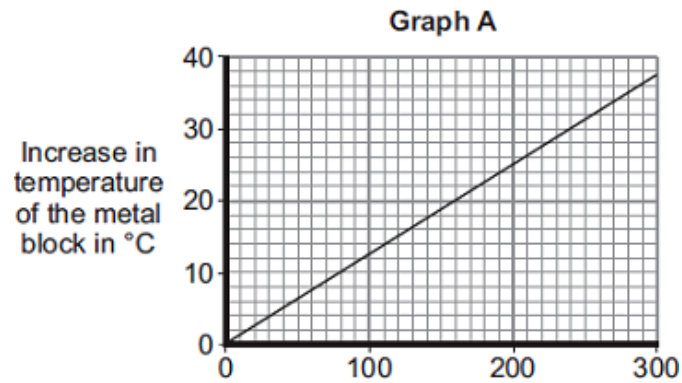

Describe the pattern shown in **Graph A**.

.....

.....

.....

.....

(2)

- (ii) The student measured the room temperature. He then switched the heater on and measured the temperature of the metal block every 50 seconds.

The student calculated the increase in temperature of the metal block and plotted **Graph B**.

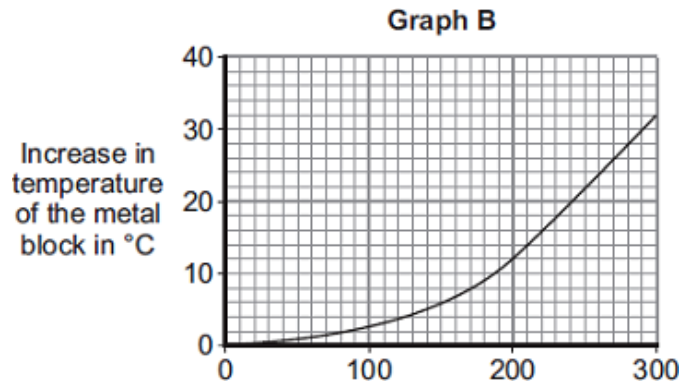

After 300 seconds, **Graph B** shows the increase in temperature of the metal block is lower than the increase in temperature expected from **Graph A**.

Suggest **one** reason why.

.....

.....

(1)

- (iii) The power of the electric heater is 50 watts.

Calculate the energy transferred to the heater from the electricity supply in 300 seconds.

Use the correct equation from the Physics Equations Sheet.

.....

.....

.....

Energy transferred = J

(2)

- (b) The student uses the same heater to heat blocks of different metals. Each time the heater is switched on for 300 seconds.

Each block of metal has the same mass but a different specific heat capacity.

Metal	Specific heat capacity in J/kg°C
Aluminium	900
Iron	450
Lead	130

Which **one** of the metals will heat up the most?

Draw a ring around the correct answer.

aluminium

iron

lead

Give, in terms of the amount of energy needed to heat the metal blocks, a reason for your answer.

.....

.....

.....

.....

(2)

- (c) A homeowner uses an electric immersion heater to heat the water in his hot water tank. The hot water tank has no insulation.

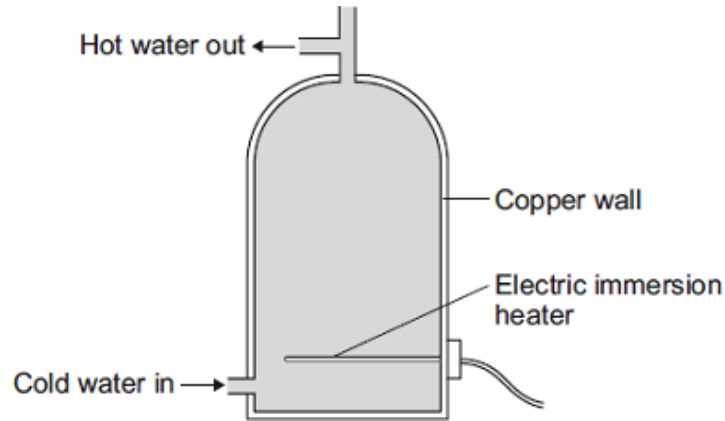

- (i) Draw a ring around the correct answer to complete each sentence.

Energy is transferred through the water by

- conduction.
- convection.
- evaporation.

Energy is transferred through the copper wall of the hot water tank by

- conduction.
- convection.
- evaporation.

(2)

- (ii) To keep the water in the tank hot for longer, the homeowner fits an insulating jacket around the tank. The insulating jacket costs £12 to buy.

The homeowner expects to save £16 each year from reduced energy bills.

Calculate the pay-back time for the insulating jacket.

.....

Pay-back time = years

(2)

(Total 11 marks)

Q4. The diagram shows the design of a solar cooker. The cooker heats water using infrared radiation from the Sun.

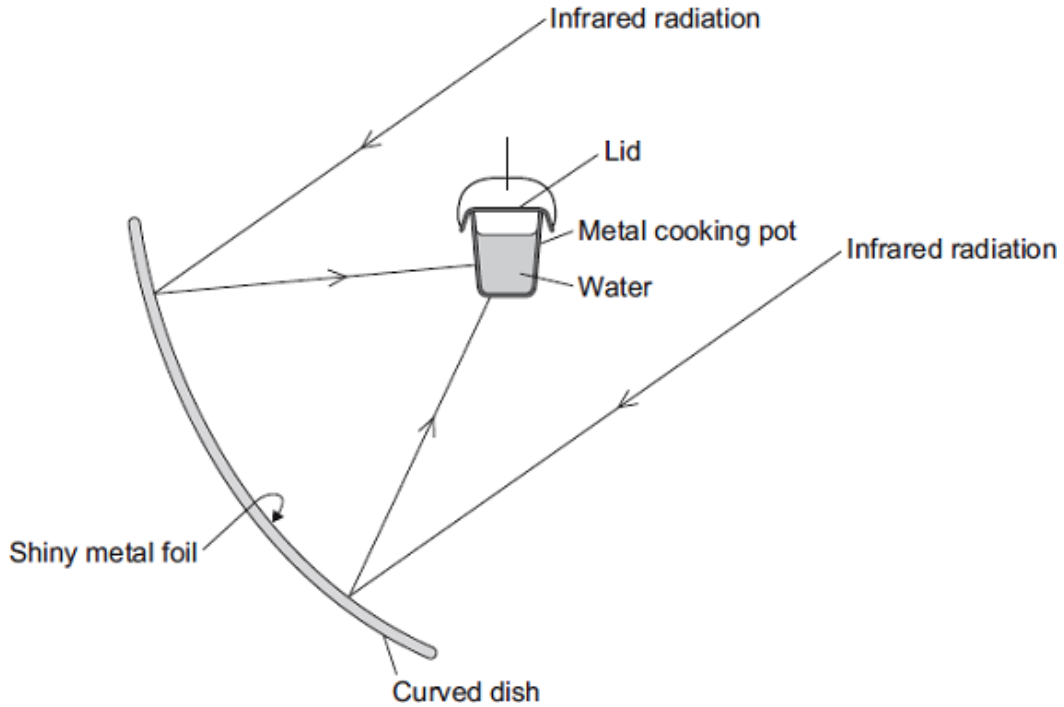

(a) Why is the inside of the large curved dish covered with shiny metal foil?

.....

(1)

(b) Which would be the best colour to paint the outside of the metal cooking pot?

Draw a ring around the correct answer.

black

silver

white

Give a reason for your answer.

.....

(2)

(c) Why does the cooking pot have a lid?

.....

(1)

- (d) Calculate how much energy is needed to increase the temperature of 2 kg of water by 80 °C.

The specific heat capacity of water = 4200 J/kg °C.

Use the correct equation from the Physics Equations Sheet.

.....

Energy = J

(2)
 (Total 6 marks)

- Q5.** (a) A student investigated how the number of blades on a wind turbine affects the output voltage of the turbine.

The student used the apparatus shown in the diagram.

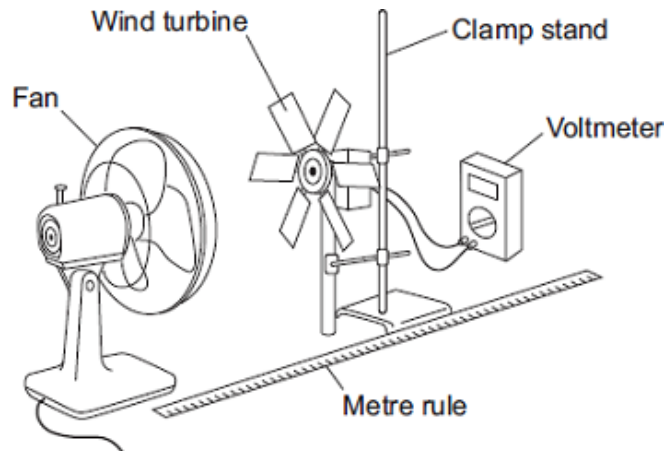

The fan was used to turn the wind turbine.

- (i) The fan was always the same distance from the wind turbine.

Why?

.....

(1)

- (ii) After switching the fan on, the student waited 20 seconds before taking the voltmeter reading.

Suggest why.

.....

(1)

(iii) The student changed the number of blades on the wind turbine.

The student's results are shown in the scatter graph.

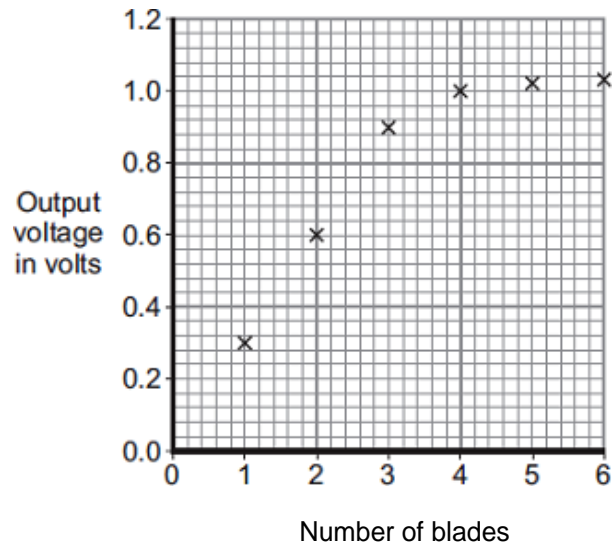

What conclusion can be made from the results in the scatter graph?

.....

.....

.....

.....

(2)

(b) The amount of electricity generated using wind turbines is increasing.

Which graph, **A**, **B** or **C**, is most likely to show the electrical power output from a wind turbine over one day?

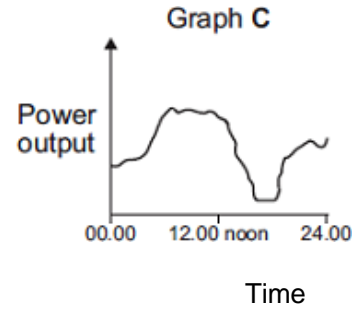
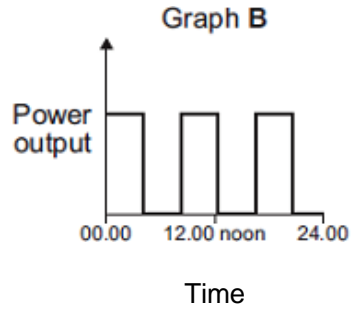
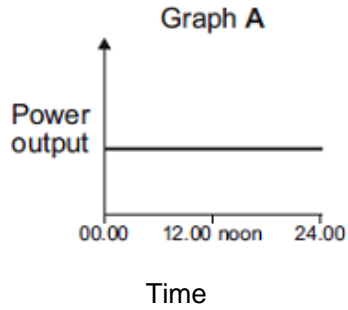

Write the correct answer, **A**, **B** or **C**, in the box.

Give a reason for your answer.

.....

.....

.....

(2)
(Total 6 marks)

Q6. A wood burning stove is used to heat a room.



Photograph supplied by iStockphoto/Thinkstock

The fire in the stove uses wood as a fuel. The fire heats the matt black metal case of the stove.

(a) The air next to the stove is warmed by infrared radiation.

How does the design of the stove help to improve the rate of energy transfer by infrared radiation?

.....

.....

.....

.....

(2)

- (b) Burning 1 kg of wood transfers 15 MJ of energy to the stove. The stove then transfers 13.5 MJ of energy to the room.

Calculate the efficiency of the stove.

Use the correct equation from the Physics Equations Sheet.

Show clearly how you work out your answer.

.....
.....
.....

Efficiency =

(2)

- (c) Some of the energy from the burning wood is wasted as the hot gases leave the chimney and warm the air outside the house.

Name **one** other way energy is wasted by the stove.

.....

(1)

- (d) Some people heat their homes using electric heaters. Other people heat their homes using a wood burning stove.

Give **two** environmental advantages of using a wood burning stove to heat a home rather than heaters that use electricity generated from fossil fuels.

1

.....

2

.....

(2)

- (e) The metal case of the stove gets hot when the fire is lit.

Here is some information about the stove.

Mass of metal case	100 kg
Starting temperature of metal case	20 °C
Final temperature of metal case	70 °C
Specific heat capacity of metal case	510 J/kg °C

Calculate the energy required to raise the temperature of the metal case to 70 °C.

Use the correct equation from the Physics Equations Sheet.

Show clearly how you work out your answer and give the unit.

.....

.....

.....

.....

Energy required =

(3)
(Total 10 marks)

- Q7.** (a) The table gives information about some ways of reducing the energy consumption in a house.

Method of reducing energy consumption	Installation cost in £	Annual saving on energy bills in £
Cavity wall insulation	250	115
Jacket for hot water tank	12	35
Upgraded central heating controls	310	80

Show that over 5 years, the most cost-effective method of reducing energy consumption is to install cavity wall insulation.

.....

.....

.....

.....

(2)

(b) Any device that transforms energy will waste energy.

Why must the total energy input to such a device always equal the total energy output from the device?

.....
.....

(1)

(c) A holiday cottage has a pre-payment electricity meter. The electricity is charged at the rate of 20 p per kWh. A £2 coin is put into the meter and a 2.5 kW fire switched on.

Use the equations in the box to work out how many hours it will be before £2 runs out. Assume that no other electrical device is switched on.

$\text{energy transferred} = \text{power} \times \text{time}$ $\text{total cost} = \text{number of kilowatt-hours} \times \text{cost per kilowatt-hour}$
--

Show clearly how you work out your answer.

.....
.....
.....
.....

Time = hours

(2)

(Total 5 marks)

Q8. The diagram below shows a house which has **not** been insulated. The cost of the energy lost from different parts of the house during one year is shown on the diagram.

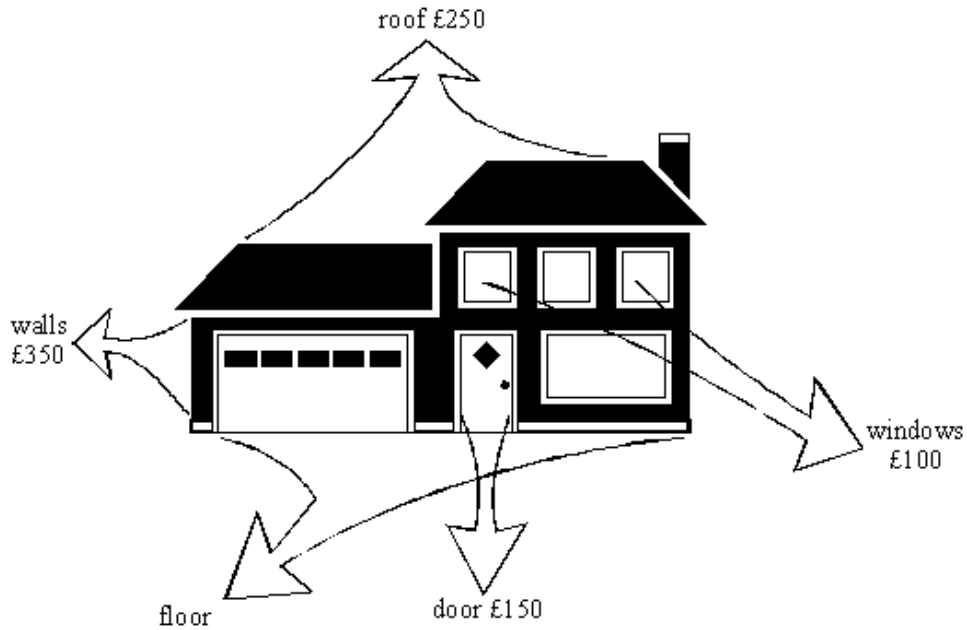

(a) The total cost of the energy lost during one year is £1000.

(i) What is the cost of the energy lost through the floor?

.....

(2)

(ii) Suggest one way of reducing this loss.

.....

(1)

(b) The table below shows how some parts of the house may be insulated to reduce energy losses. The cost of each method of insulation is also given.

WHERE LOST	COST OF ENERGY LOST PER YEAR (£)	METHOD OF INSULATION	COST OF INSULATION (£)
roof	250	fibre-glass in loft	300
walls	350	foam filled cavity	800
windows	100	double glazing	4500
doors	150	draught proofing	5

(i) Which method of insulation would you install first? Explain why.

.....
.....
.....
.....

(3)

(ii) Which method of insulation would you install last? Explain why.

.....
.....
.....
.....

(3)

(Total 9 marks)

Q9. The diagram below shows an electric kettle and the label on the bottom of the kettle.

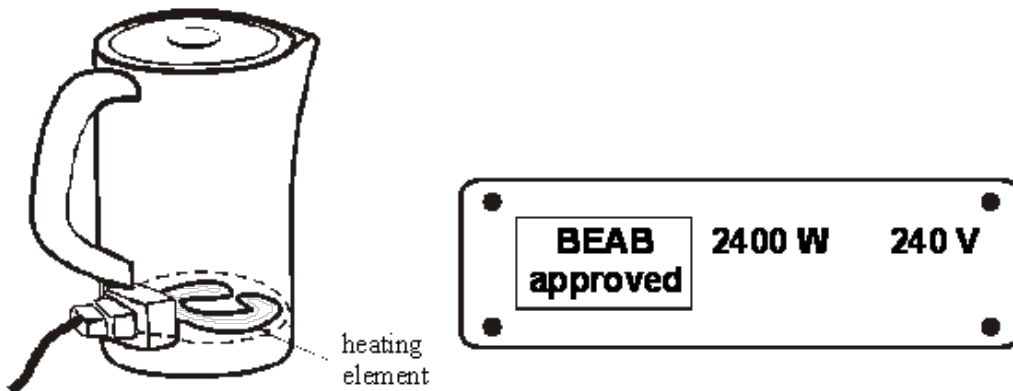

The water at the bottom of the kettle will heat up first.
This is because the heating element is near the bottom of the kettle.
Convection currents will then cause the rest of the water in the kettle to be heated.

(i) What are convection currents?

.....

(1)

- (ii) Explain how convection currents are produced.
(Your answer should refer to **density** and **temperature**.)

.....

.....

.....

.....

.....

(4)
(Total 5 marks)

M1.

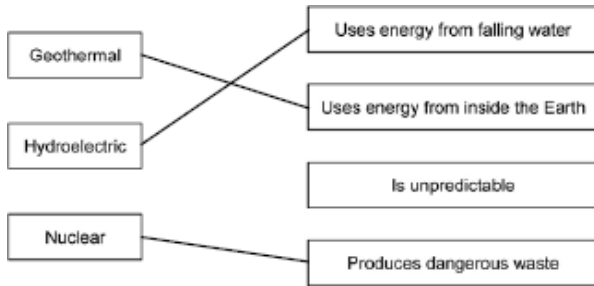

allow 1 mark for each correct line
if more than one line goes from an energy source then all lines
from that energy source are wrong

[3]

M2. (a) (i) Z

1

(ii) X

1

(b) (i) moving randomly

1

(ii) stronger than

1

(c) (i) evaporation

1

(ii) any **one** from:

- becomes windy
- temperature increases
accept (becomes) sunny
"the sun" alone is insufficient
- less humid

1

[6]

M3. (a) (i) temperature (increase) and time switched on are directly proportional
accept the idea of equal increases in time giving equal increases in temperature
answers such as:

- *as time increases, temperature increases*
- *positive correlation*
- *linear relationship*
- *temperature and time are proportional*

score 1 mark

2

- (ii) any **one** from:
- *“it” refers to the metal block*
 - energy transfer (from the block) to the surroundings
accept lost for transfer
accept air for surroundings
 - (some) energy used to warm the heater / thermometer (itself)
accept takes time for heater to warm up
 - (metal) block is not insulated

1

- (iii) 15 000
- allow 1 mark for correct substitution, ie 50 × 300 provided no subsequent step shown*

2

- (b) lead
- reason only scores if lead is chosen*

1

- needs least energy to raise temperature by 1°C
- accept needs less energy to heat it (by the same amount)*
lowest specific heat capacity is insufficient

1

- (c) (i) convection
- correct order only*

1

conduction

1

- (ii) 3 / 4 (year)
- or**
- allow 1 mark for correct method, ie $\frac{12}{16}$ shown*
- 0.75
- or**
- 9 months
- or**
- 274 days

2

[11]

- M4.** (a) to reflect (the infrared)
- accept (shiny surfaces) are good reflectors*
ignore reference to incorrect type of wave

1

(b) black 1

best absorber (of infrared)

answer should be comparative
black absorbs (infrared) is insufficient
accept good absorber (of infrared)
ignore reference to emitter
ignore attracts heat
ignore reference to conduction

1

(c) to reduce energy loss

accept to stop energy loss
accept heat for energy
accept to stop / reduce convection

or

so temperature of water increases faster

accept to heat water faster
accept cooks food faster

or

reduces loss of water (by evaporation)

1

(d) 672 000

allow 1 mark for correct substitution, ie $2 \times 4200 \times 80$ provided no subsequent step shown

2

[6]

M5. (a) (i) changing the distance may / will affect / change the voltmeter reading

accept so only one independent variable
accept distance affects speed of wind (turbine)
accept it is a control variable
accept to give valid results
fair test is insufficient
to make the results accurate is insufficient

1

(ii) any sensible practical suggestions, eg

- so fan reaches a steady / full speed
accept power for speed
- so wind (turbine) reaches a steady / full speed
- so voltmeter reaches / gives a steady reading
accept accurate or valid reading a correct reading is insufficient
*do **not** accept precise reading*

1

- (iii) as the number of blades increases so does the (voltmeter) reading / output / voltage

number of blades affects the reading / output is insufficient

1

further relevant detail, eg

- voltmeter increase is greatest up to 3 blades
- voltmeter reading hardly changes with 4, 5 or 6 blades
accept does not change between 4 and 6 blades
- increase is directly proportional up to 3 blades
- it reaches a limit
accept does not change after 4 / 5 blades
- a numerical example giving two pairs of numbers, eg 2 blades = 0.6V, 4 blades = 1V

1

- (b) C

reason scores only if C is chosen

1

wind speed / strength varies

*accept wind is **not** constant / reliable*

1

[6]

- M6.** (a) any **two** from:

- black is a good emitter of (infrared radiation)
accept heat for radiation
ignore reference to absorbing radiation
- large surface (area)
- matt surfaces are better emitters (than shiny surfaces)
accept matt surfaces are good emitters
ignore reference to good conductor

2

- (b) 90% or 0.9(0)

$$\text{efficiency} = \frac{\text{useful energy out} (\times 100\%)}{\text{total energy in}}$$

allow 1 mark for correct substitution, ie $\frac{13.5}{15}$

provided no subsequent step shown

an answer of 90 scores 1 mark

an answer of 90 / 0.90 with a unit scores 1 mark

2

(c) (producing) light
allow (producing) sound 1

(d) any **two** from:

- wood is renewable
accept wood grows again / quickly
accept wood can be replanted
- (using wood) conserves fossil fuels
accept doesn't use fossil fuels
- wood is carbon neutral
accept a description
cheaper / saves money is insufficient

2

(e) $E = m \times c \times \theta$
2 550 000
allow 1 mark for correct substitution
ie $100 \times 510 \times 50$
provided no subsequent step shown
answers of 1 020 000, 3 570 000 gain 1 mark 2

joules /J
accept kJ / MJ
*do **not** accept j*
for full credit the unit and numerical answer must be consistent 1

[10]

M7. (a) total saving shown for each method
ie:
cavity wall £325
jacket £163
central heating £90
allow 1 mark for one correctly calculated value
or
allow 1 mark for showing energy bill savings for each method over 5 years
ie:
cavity wall £575
jacket £175
central heating £400
there are no marks for calculation of payback time 2

(b) energy cannot be destroyed
accept energy is conserved
ignore reference to created 1

(c) 4 (hours)
allow 1 mark for obtaining number of kWh = 10
or energy transferred = 10 2

[5]

M8. (a) (i) £150
gets 2
Else $1000 - (250 + 350 + 100 + 150)$ or $1000 - 850$
gets 1 2

(ii) (Named) floor covering
OR Insulation under floor
for 1 mark 1

(b) (i) Draught proof doors or fibre glass in loft or in cavity
For draught proofing
gains 1 mark
Very low cost/easy to install
Repays for itself quickly/cost recuperated quickly
Reasonable energy saving
any 2 for 1 mark each

For loft insulation

Second lowest installation cost/easy to install
Reasonable large energy savings for this cost
Reasonable payback time
gains 1 mark

For foam filled cavity
Biggest energy/cash saving
Cost effective
any 2 for 1 mark each 3

(ii) **Double glazing**

gains 1 mark

Costs most
Saves least energy
Least cost effective

any 2 for 1 mark each

3

[9]

M9. (i) currents of moving liquids/gases/fluids carrying/transferring energy
(can name fluid)

1

(ii) liquids/gases **expand** when their temperature rises/when they are heated

the **density** of the heated liquid/gas is then **less** than that of the
colder liquid/gas which has not been heated

the warmer/less dense liquid/gas **then rises** through the colder/denser liquid/gas

the **colder/denser liquid/gas falls** to replace the liquid/gas which has risen,
and in turn becomes heated

for 1 mark each

4

[5]

