

Centre Number						Candidate Number				
Surname										
Other Names										
Candidate Signature										



General Certificate of Secondary Education
Foundation Tier
November 2013

Mathematics (Linear)

4365/2F

Paper 2

Monday 11 November 2013 9.00 am to 10.45 am

F

For this paper you must have:

- a calculator
- mathematical instruments.



Time allowed

- 1 hour 45 minutes

Instructions

- Use black ink or black ball-point pen. Draw diagrams in pencil.
- Fill in the boxes at the top of this page.
- Answer **all** questions.
- You must answer the questions in the spaces provided. Do not write outside the box around each page or on blank pages.
- Do all rough work in this book.
- If your calculator does not have a π button, take the value of π to be 3.14 unless another value is given in the question.

Information

- The marks for questions are shown in brackets.
- The maximum mark for this paper is 105.
- The quality of your written communication is specifically assessed in Questions 6, 7 and 16. These questions are indicated with an asterisk (*).
- You may ask for more answer paper, tracing paper and graph paper. These must be tagged securely to this answer book.

Advice

- In all calculations, show clearly how you work out your answer.

For Examiner's Use	
Examiner's Initials	
Pages	Mark
3	
4–5	
6–7	
8–9	
10–11	
12–13	
14–15	
16–17	
18–19	
20–21	
22–23	
24–25	
26–27	
28	
TOTAL	



N 0 V 1 3 4 3 6 5 2 F 0 1

WMP/Nov13/4365/2F/E4

4365/2F

Formulae Sheet: Foundation Tier

Area of trapezium = $\frac{1}{2}(a+b)h$

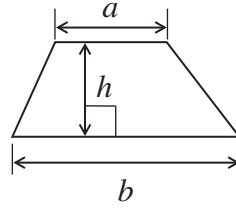

Volume of prism = area of cross-section \times length

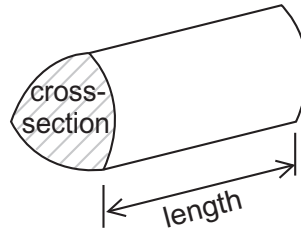

Answer **all** questions in the spaces provided.

1 Use a calculator to work out each of the following.

1 (a) 206×13

Answer (1 mark)

1 (b) $945 \div 15$

Answer (1 mark)

1 (c) $489 - (15 \times 14)$

Answer (1 mark)

Turn over for the next question



2 Jon records the number of cold drinks he has each day.

	Monday	Tuesday	Wednesday	Thursday	Friday
Number of cold drinks	6	8	3	7	5

He uses the information to draw this bar chart.

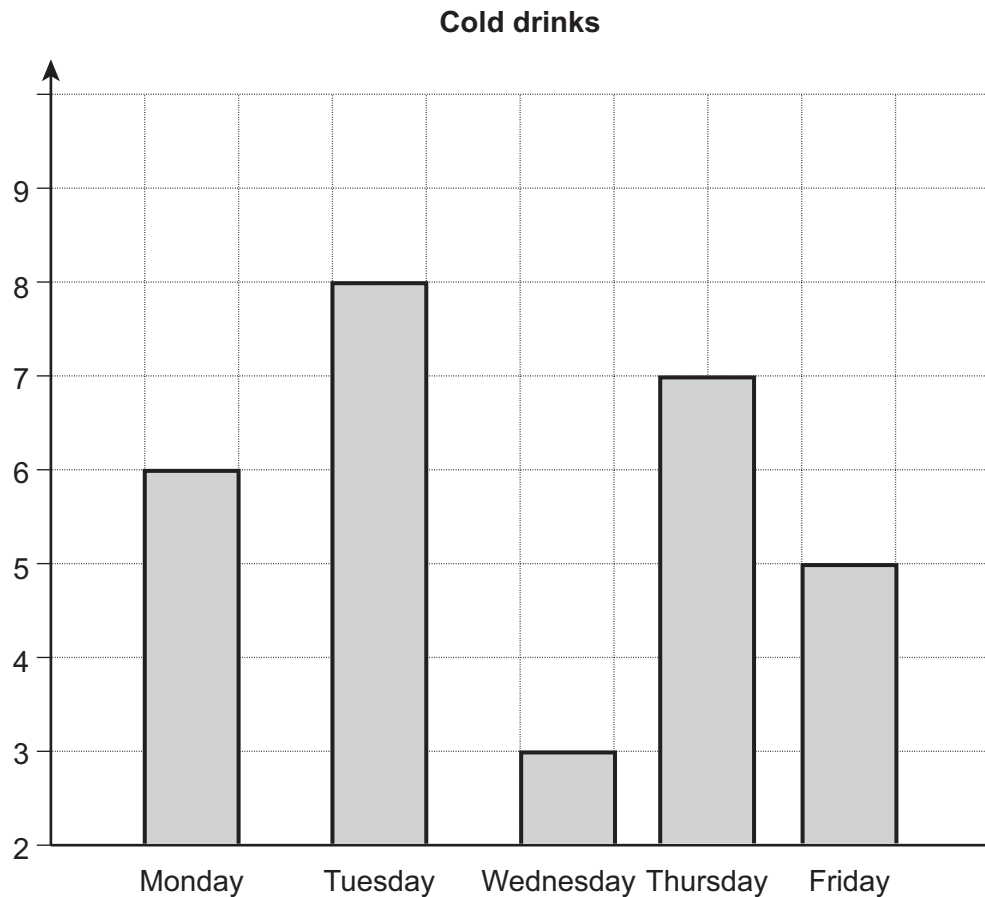

Write down **three** mistakes that he has made.

Mistake 1

Mistake 2

Mistake 3

(3 marks)



3 How much of each shape is shaded?
Tick the correct box.

3 (a)

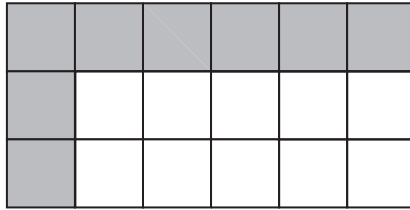

Less than $\frac{1}{2}$

Exactly $\frac{1}{2}$

More than $\frac{1}{2}$

(1 mark)

3 (b)

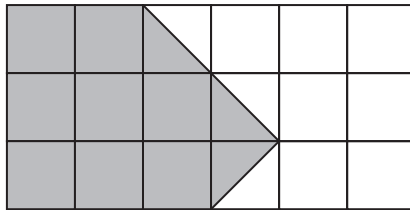

Less than $\frac{1}{2}$

Exactly $\frac{1}{2}$

More than $\frac{1}{2}$

(1 mark)

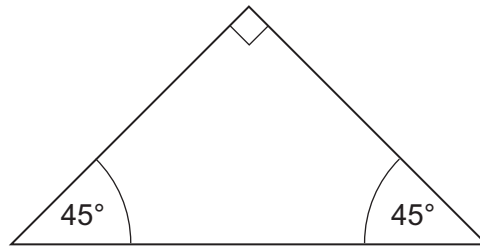

4

Not drawn
accurately

4 (a) Circle the correct word to complete the sentence.

This right-angled triangle is

scalene

isosceles

equilateral

(1 mark)

4 (b) How many lines of symmetry does the triangle have?

Answer

(1 mark)



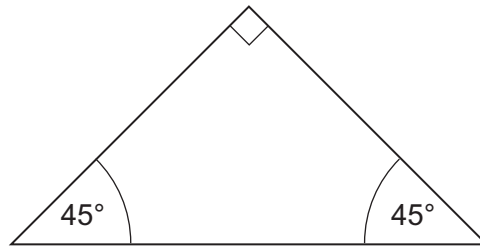

Not drawn
accurately

4 (c) Draw a sketch to show how **two** of these triangles fit together to make a square.

(1 mark)

4 (d) Draw a sketch to show how **four** of these triangles fit together to make a square.

(1 mark)

4

Turn over ►



5 This method shows how you can square two-digit numbers that end in the digit 5.

Example 35^2

Write down the tens digit	3
Add 1 and multiply this by the tens digit	$4 \times 3 = 12$
Put this answer to the left of 25	1225
	So $35^2 = 1225$

5 (a) Use the same method to work out 75^2
You **must** show your working.

.....

.....

.....

Answer (2 marks)

5 (b) Use the method backwards to work out the square root of 4225
You **must** show your working.

.....

.....

.....

Answer (2 marks)



6 Here are some share prices.
All prices are in **pence** per share.

PETRO	415
ZTV	77
T & B	335
NEWTON	3451

6 (a) Work out the cost of 25 NEWTON shares.
Give your answer in pounds.

.....
.....

Answer £ (2 marks)

***6 (b)** George has £5000 to buy some PETRO shares.
Work out the largest number of shares that he could buy.

.....
.....
.....

Answer (3 marks)



7 Here is some information about temperatures in Italy in January.

	Minimum temperature (°C)	Maximum temperature (°C)
Northern Italy	-4	5
Central Italy	5	13
Southern Italy	10	16

7 (a) Which part of Italy is coldest in January?

Answer (1 mark)

7 (b) Which part of Italy has the smallest range in temperature in January?
You **must** show your working.

.....
.....
.....

Answer (2 marks)



7 (c) The temperatures in a town in Italy on five days in January are

10 °C

5 °C

11 °C

7 °C

12 °C

Work out the mean temperature.

.....
.....

Answer °C (2 marks)

***7 (d)** Which part of Italy do you think the town in part (c) is in?
Give a reason for your answer.

Answer

Reason

(1 mark)

Turn over for the next question



8

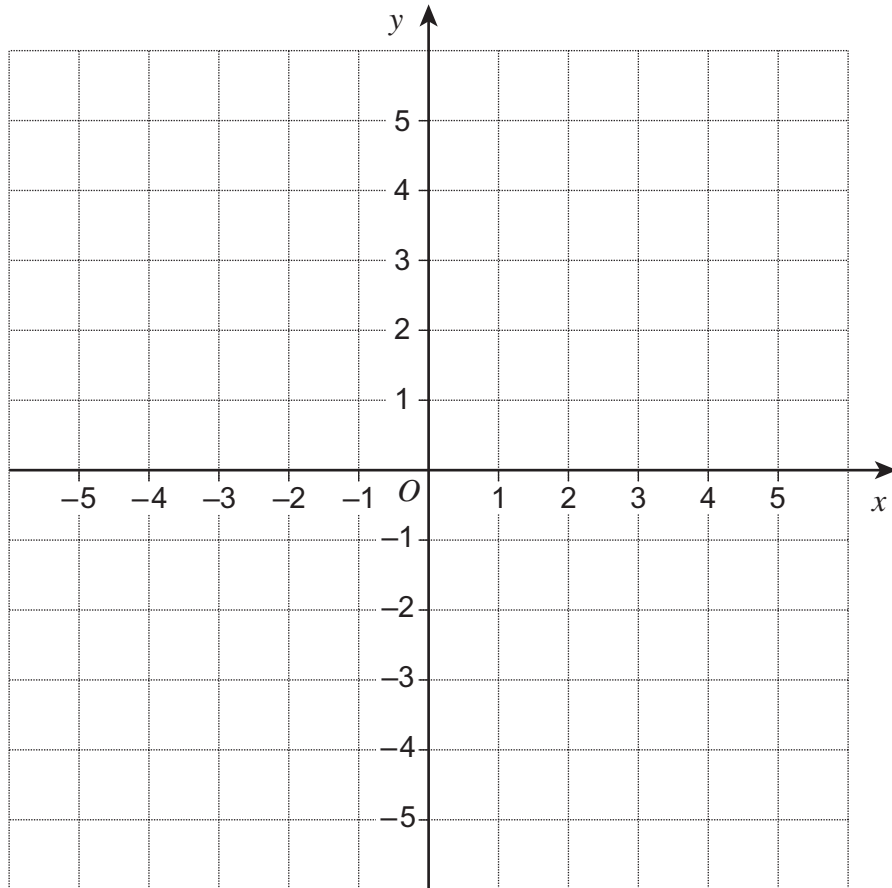

8 (a) Plot the points $A(4, 3)$ and $B(1, -5)$ on the grid.

(2 marks)

8 (b) Point C has

the same x -coordinate as B
the same y -coordinate as A .

Plot the point C on the grid.

(1 mark)

8 (c) Point D has

the same x -coordinate as the y -coordinate of B
the same y -coordinate as the x -coordinate of A .

Plot the point D on the grid.

(2 marks)



9 20 students choose a sport.

Boy	Tennis
Girl	Basketball
Girl	Tennis
Boy	Football
Boy	Tennis
Girl	Football
Boy	Tennis
Boy	Football
Boy	Basketball
Girl	Tennis

Girl	Football
Boy	Basketball
Girl	Tennis
Girl	Tennis
Girl	Tennis
Boy	Football
Boy	Football
Girl	Basketball
Boy	Basketball
Boy	Football

9 (a) How many boys choose tennis?

Answer (1 mark)

9 (b) Put the information into the two-way table.
Remember to complete the totals.

	Tennis	Basketball	Football	Total
Boys				
Girls				
Total				20

(4 marks)



10 The number of tickets sold for five football matches is shown.

Match	Tickets sold
1	43 378
2	19 872
3	20 417
4	43 685
5	32 473

10 (a) At which match were most tickets sold?

Answer (1 mark)

10 (b) At which match was the number of tickets sold closest to 20 000?

.....
.....

Answer (2 marks)

10 (c) 3584 of the tickets sold for match 5 were **not** used.

How many tickets were used for match 5?
Give your answer to the nearest thousand.

.....
.....
.....
.....

Answer (3 marks)



11 (a) *AB* is a straight line.

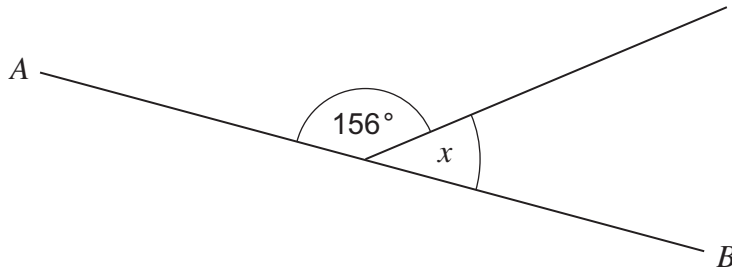

Not drawn
accurately

Work out the size of angle x .

.....

Answer degrees (2 marks)

11 (b) Work out the size of angle y .

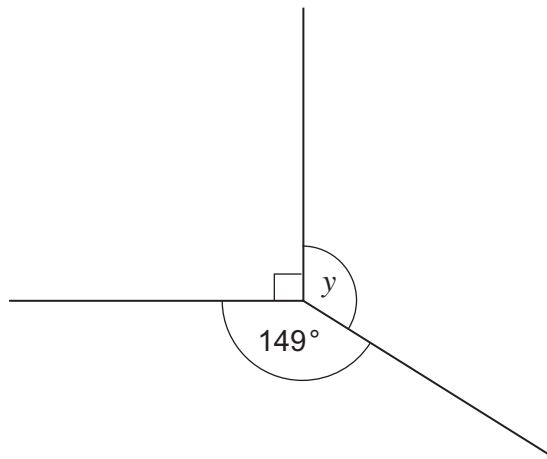

Not drawn
accurately

.....

.....

Answer degrees (2 marks)



12 Solve the equations.

12 (a) $x - 19 = 43$

.....

$x =$ (1 mark)

12 (b) $9y = 72$

.....

$y =$ (1 mark)

12 (c) $\frac{w}{5} = 10$

.....

$w =$ (1 mark)



13 Shapes A and B are drawn on the rectangular grid.

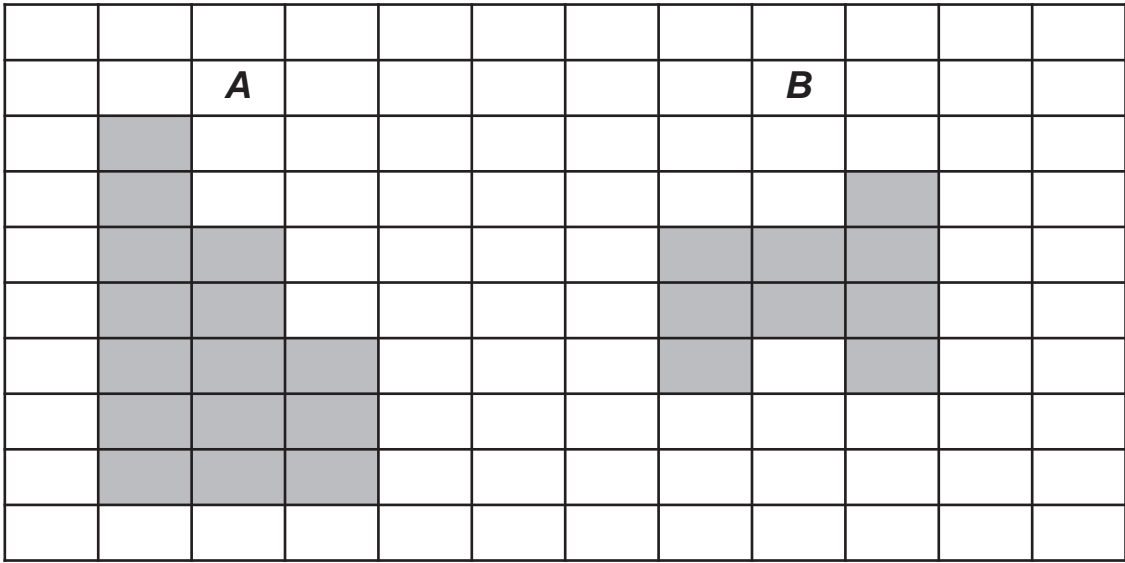

The area of shape A is 75 cm²

Work out the area of shape B.

.....

.....

.....

.....

.....

.....

Answer cm² (4 marks)



14 This water tank is a cuboid.

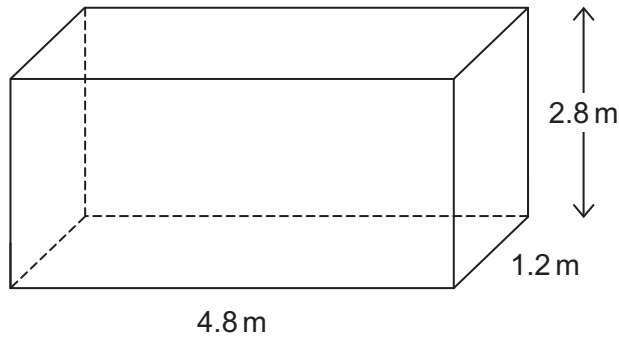

14 (a) Work out the volume of the tank.
State the units of your answer.

.....

.....

Answer (3 marks)

14 (b) One quarter of the tank is filled with water.

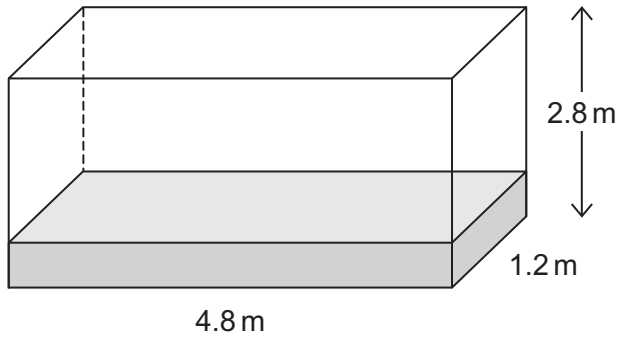

1 cubic metre holds 1000 litres of water.

Work out how many **more** litres of water are needed to fill the tank.

.....

.....

.....

Answer litres (3 marks)



15 Complete this bill.

Dwayne's Plumbing 3 Pipe Way, Looe	
Mrs Leak Flood Lane Looe	
Date 1st November 2013	
Bath	£1295.00
Sink	£475.00
Labour	£350.00
Total before Value Added Tax (VAT)
VAT at 20%
Total to pay

(4 marks)

Turn over for the next question

10

Turn over ►



16 (a) Simplify fully $6x + 4y - x - 7y$

.....

Answer (2 marks)

***16 (b)** Matt knows the value of a is 6 or 7 and the value of b is 4 or 5.

Work out the largest and smallest possible values of $3a - 2b$

.....
.....
.....
.....

Largest

Smallest (4 marks)



17 Here is a set of data.

2.5 1.7 2.4 1.6 1.3

The mean is 1.9

17 (a) Each piece of data is increased by 15.

Work out the new mean.

Answer (1 mark)

17 (b) Each **new** piece of data is now doubled.

Work out the new mean.

.....
.....

Answer (2 marks)

Turn over for the next question



18 (a) Complete the table of values for $y = 2x - 1$

x	-2	-1	0	1	2
y	-5			1	

(2 marks)

18 (b) On the grid, draw the graph of $y = 2x - 1$ for values of x from -2 to 2.

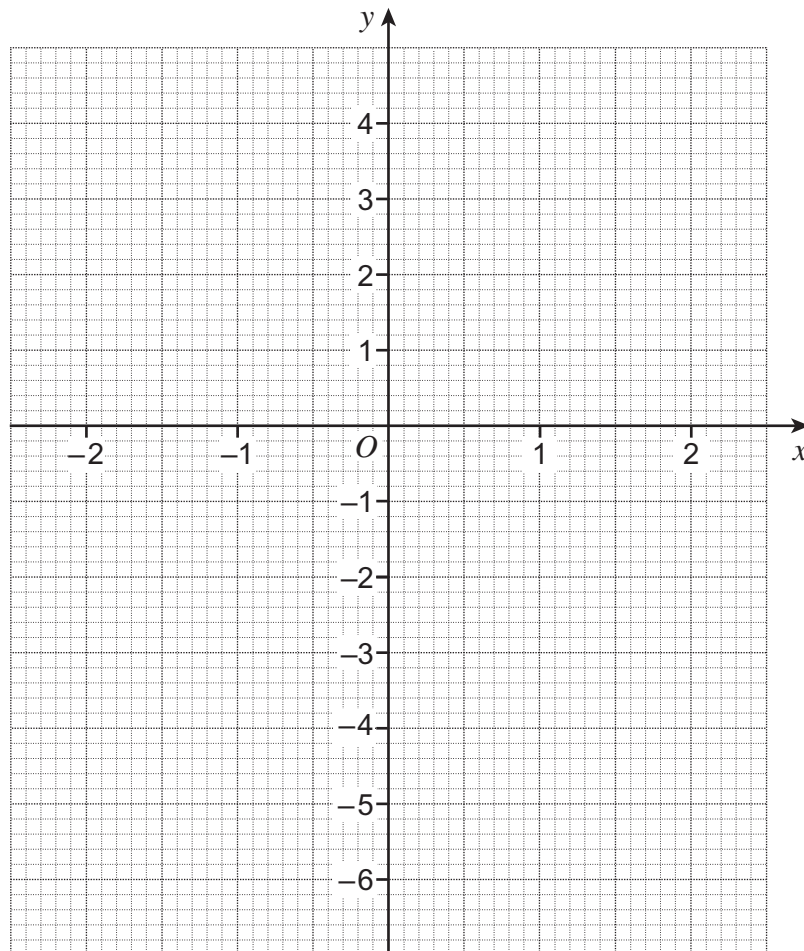

(2 marks)



19 In this question, assume that the car uses the same amount of petrol for each mile it travels.

19 (a) A car uses 55 litres of petrol to travel 495 miles.
How far would the car travel on 80 litres of petrol?

.....
.....
.....

Answer miles (3 marks)

19 (b) How much petrol would the car use on a trip of 160 miles?
Give your answer to the nearest litre.

.....
.....
.....

Answer litres (4 marks)

Turn over for the next question



20 Decide whether each of these sets of data is discrete or continuous.

Tick the correct box.

20 (a) The heights of people.

Discrete

Continuous

(1 mark)

20 (b) The number of coins in a bag.

Discrete

Continuous

(1 mark)

20 (c) The weights of bicycles.

Discrete

Continuous

(1 mark)

20 (d) The shoe sizes of women.

Discrete

Continuous

(1 mark)



21 The hexagon is made from a rectangle and two congruent triangles.

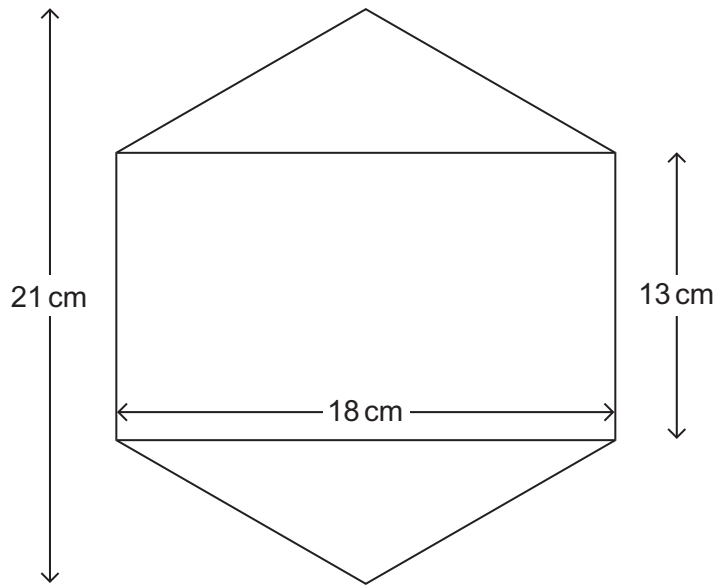

Not drawn
accurately

Work out the area of the hexagon.

.....

.....

.....

.....

.....

.....

.....

Answer cm² (5 marks)



22 (a) Rearrange the formula to make w the subject of $y = 3w + 8$

.....
.....

Answer (2 marks)

22 (b) Solve $5(x + 4) = 3x + 23$

.....
.....
.....
.....

$x =$ (3 marks)



23

A square of side 15.7 cm is made from a length of wire.

The same length of wire is then made into a circle.

Not drawn
accurately

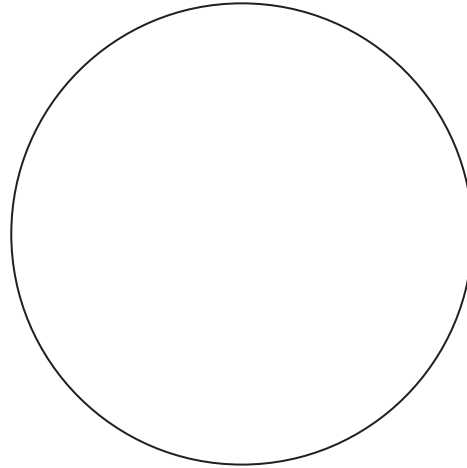
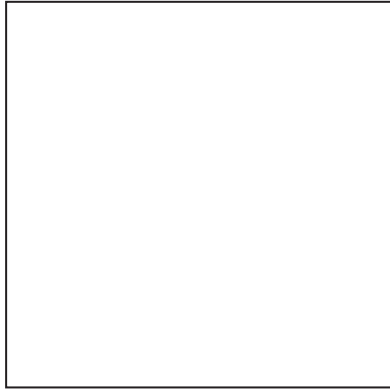

Work out the diameter of the circle.

.....

.....

.....

.....

.....

.....

.....

.....

.....

.....

Answer cm (4 marks)



24

The diagram shows a sketch of triangle ABC .

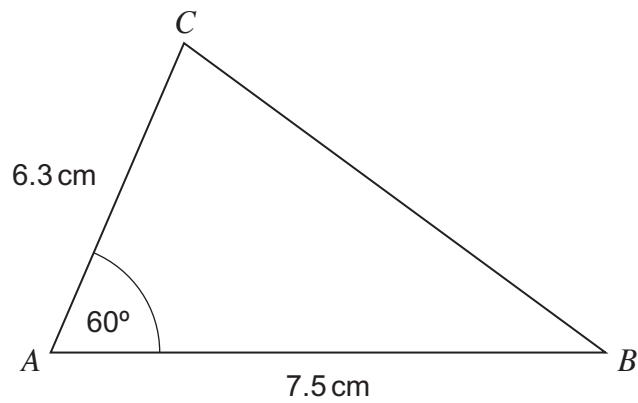

Not drawn
accurately

Using ruler and compasses only, make an accurate drawing of triangle ABC .

(3 marks)

END OF QUESTIONS

