

- Q1.** (a) A student takes off his nylon fleece and feels a small electric shock. He realises that this happens because his fleece becomes charged.

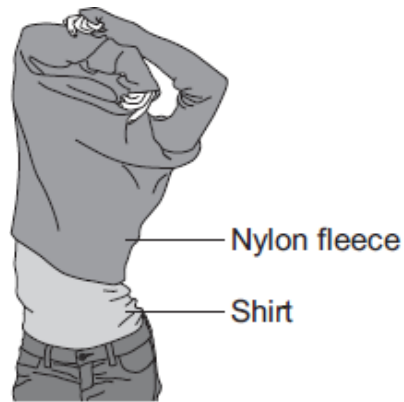

Explain why the fleece becomes charged.

.....

.....

.....

.....

.....

(2)

- (b) Only **two** of the following statements are correct.

Put a tick (✓) in the boxes next to the **two** correct statements.

Positively charged objects repel negatively charged objects.

Electrical charges move easily through metals.

Static electricity is safe; it never causes any danger.

An electric current is a flow of electrical charge.

(2)

- (c) The diagram shows a lightning conductor attached to the side of a tall building.

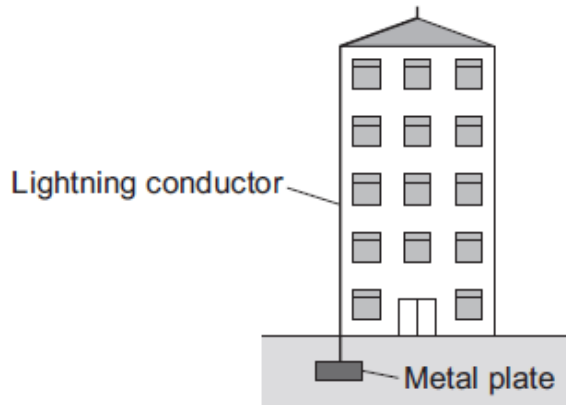

If the building is struck by lightning, charge flows to earth through the lightning conductor.

- (i) Which of the materials in the list is used to make the lightning conductor?

Draw a ring around your answer.

copper

glass

plastic

Give a reason for your answer.

.....
.....
.....

(2)

- (ii) Complete the sentence by drawing a ring around the correct line in the box.

The resistance of the lightning conductor is

higher than	the resistance of the building.
the same as	
lower than	

(1)

- (iii) It is almost impossible to test different designs of lightning conductor in controlled experiments during a lightning storm.

Suggest a reason why.

.....
.....

(1)

(Total 8 marks)

Q2. (a) Complete the sentence below to name the instrument used to measure electrical current.

The instrument used to measure electrical current is called

(1)

(b) In the diagram below each box contains an electrical component or a circuit symbol. Draw straight lines to link each electrical component to its circuit symbol. The first one has been done for you.

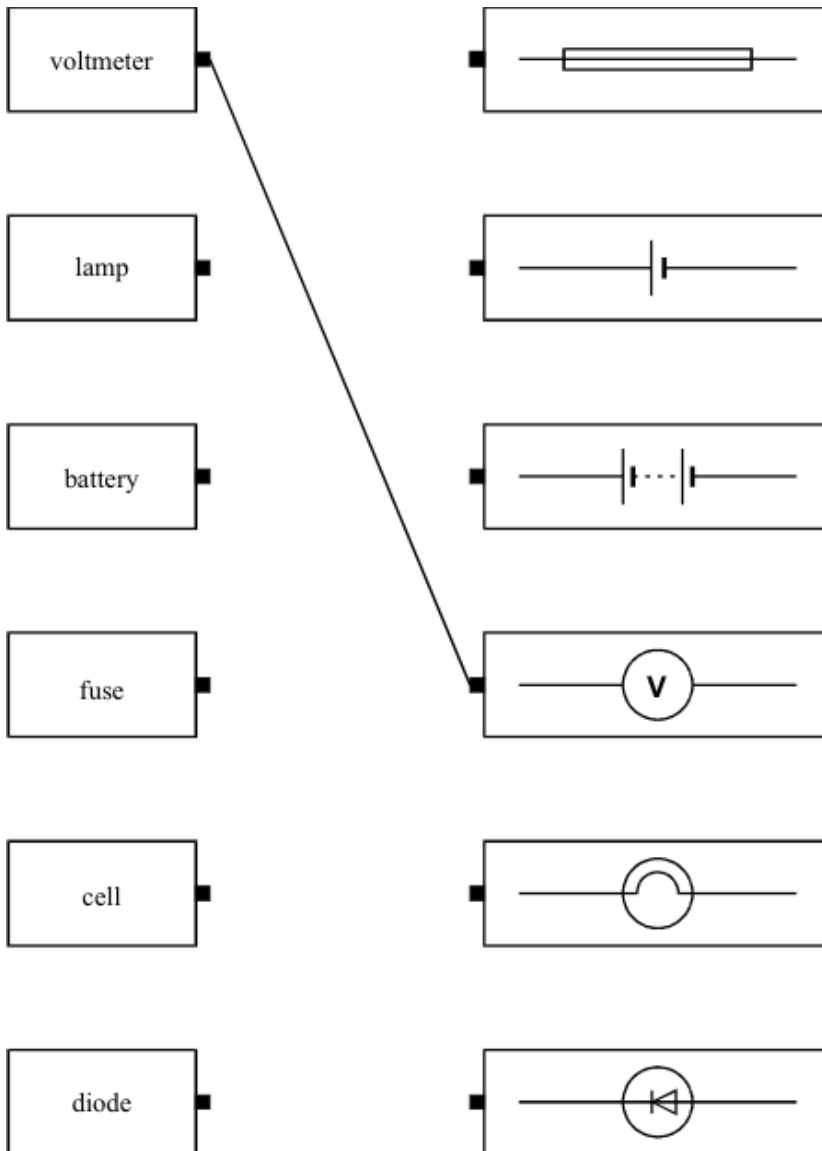

(4)
(Total 5 marks)

Q3. The diagram shows a simple type of car rear window heater. The six heating elements are exactly the same.

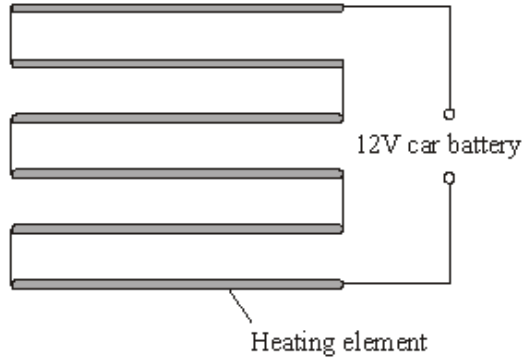

Each heating element has a resistance of 5Ω . The current passing through each element is 0.4 A .

(i) Calculate the total resistance of the six heating elements.

Show clearly how you work out your answer.

.....

Total resistance = ohms

(2)

(ii) Why is the current passing through each element the same?

.....

(1)

(iii) What is the total current passing through the whole circuit?

.....

(1)

(iv) How is the 12 volt potential difference of the car battery shared between the six heating elements?

.....

(1)

(Total 5 marks)

Q4. To gain full marks in this question you should write your ideas in good English. Put them into a sensible order and use the correct scientific words.

Explain briefly how stars like the Sun are thought to have been formed.

.....
.....
.....
.....

(Total 2 marks)

Q5. A pupil did an experiment following the instructions below.

1. Take a polythene rod (AB), hold it at its centre and rub both ends with a cloth.
2. Suspend the rod, without touching the ends, from a stand using a stirrup and nylon thread.
3. Take a perspex rod (CD) and rub it with another cloth.
4. Without touching the ends of the perspex rod bring each end of the perspex rod up to, but without touching, each end of the polythene rod.
5. Make notes on what is observed.

The diagram below shows how the apparatus is to be set up.

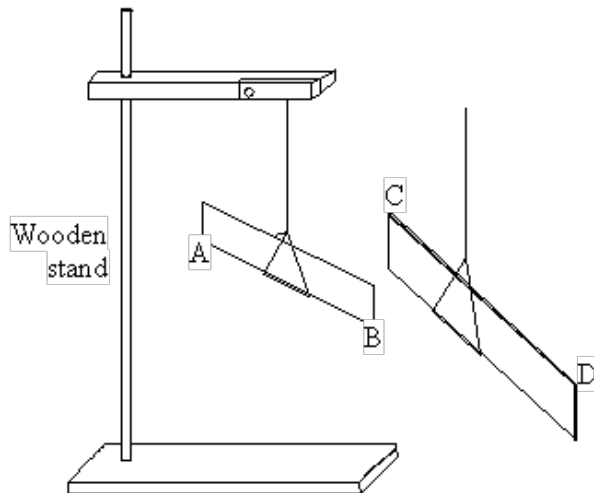

- (a) When end C was brought near to end B they attracted each other.
- (i) Explain why they attracted each other.

.....
.....

(ii) What would happen if end C were brought near end A?

.....

(3)

(b) The experiment was repeated with two polythene rods.

(i) Describe what you would expect the pupil to observe as the end of one rod was brought near to the end of the other.

.....
.....

(ii) Explain your answer.

.....
.....

(2)

(c) Explain, in terms of electron movement, what happened as the rods were rubbed with the cloths.

.....
.....
.....
.....
.....

(3)

(Total 8 marks)

Q6. The circuit shown has four identical ammeters.

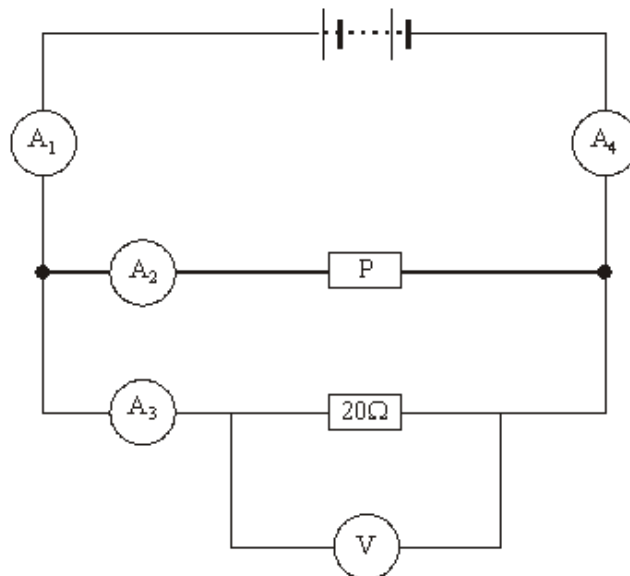

(a) The table gives the current through two of the ammeters.

(i) Complete the table to show the current through the other two ammeters.

Ammeter	Reading on ammeter in amps
A ₁	
A ₂	0.2
A ₃	0.3
A ₄	

(2)

(ii) Which **one** of the following statements is correct. Tick (✓) the box next to your choice.

The resistance of **P** is more than 20 Ω.

The resistance of **P** is equal to 20 Ω.

The resistance of **P** is less than 20 Ω.

Give a reason for your choice.

.....
.....
.....

(2)

(b) (i) Write down the equation that links current, potential difference and resistance.

.....

(1)

(ii) Calculate the reading on the voltmeter. Show clearly how you work out your answer.

.....
.....

Voltmeter reading = volts.

(2)

(iii) State the potential difference of the power supply.

.....

(1)

(c) A second circuit contains an unknown component labelled **X**.

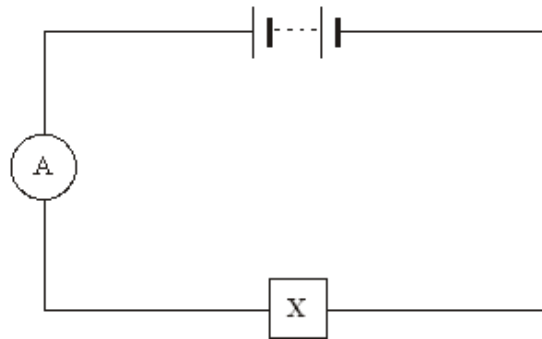

As component **X** is heated, the reading on the ammeter goes up.

What is component **X**?

.....

Give a reason for your answer.

.....

.....

(2)
(Total 10 marks)

Q7. The table gives information about the three types of particle that make up an atom.

Particle	Relative mass	Relative charge
Proton		+1
Neutron	1	
Electron	very small	-1

(a) Complete the table by adding the **two** missing values.

(2)

(b) Use the information in the table to explain why an atom has no overall electrical charge.

.....

.....

.....

.....

(2)

(c) Uranium has two natural isotopes, uranium-235 and uranium-238.
 Uranium-235 is used as a fuel inside a nuclear reactor.
 Inside the reactor, atoms of uranium-235 are split and energy is released.

(i) How is the structure of an atom of uranium-235 different from the structure of an atom of uranium-238?

.....

(1)

(ii) The nucleus of a uranium-235 atom must absorb a particle before the atom is able to split.

What type of particle is absorbed?

.....

(1)

(iii) The nucleus of an atom splits into smaller parts in a reactor.

What name is given to this process?

.....

(1)

(Total 7 marks)

Q8. Stars go through a life cycle.

Some stars will finish their life cycle as a black dwarf and other stars as a black hole.

(a) The table below gives the mass, relative to the Sun, of three stars, **J**, **K** and **L**.

Star	Mass of the star relative to the Sun
J	0.5
K	14.5
L	20.0

Which **one** of the stars, **J**, **K** or **L**, will become a black dwarf?

Give a reason for your answer.

.....

(2)

(b) Scientists can take the measurements needed to calculate the mass of many stars.

Scientists cannot calculate the mass of the star Betelgeuse.

They estimate that the star has a mass between 8 and 20 times the mass of the Sun.

(i) Betelgeuse is in the red super giant stage of its life cycle.

What will happen to Betelgeuse at the end of the red super giant stage?

.....
.....

(1)

(ii) Suggest **one** reason why scientists can only estimate and **not** calculate the mass of Betelgeuse.

.....
.....
.....

(1)

(iii) In the future, it may become possible for scientists to calculate the mass of Betelgeuse.

Suggest **one** reason why.

.....
.....
.....

(1)

- (b) The diagram shows how the electric supply cable is connected to an electric kettle. The earth wire is connected to the metal case of the kettle.

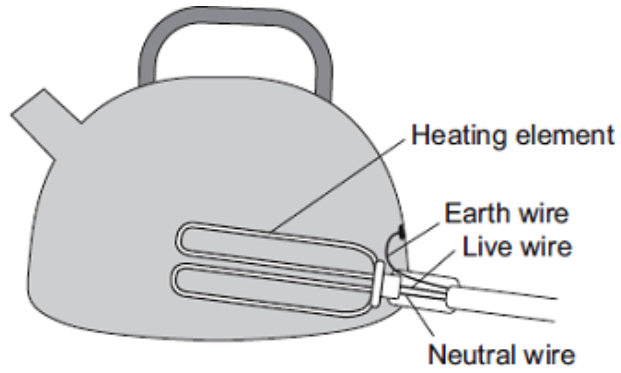

If a fault makes the metal case live, the earth wire and the fuse inside the plug protect anyone using the kettle from an electric shock.

Explain how.

.....

.....

.....

.....

(2)
(Total 4 marks)

- M1. (a) fleece rubs against shirt
it refers to the fleece 1
- or**
friction (between fleece and shirt)
- (causing) electrons to transfer from one to the other
accept a specific direction of transfer
do **not** accept charge for electrons
positive electrons negates this mark
movement of protons negates this mark 1
- (b) Electrical charges move easily through metals. 1
- An electric current is a flow of electrical charge. 1
- (c) (i) copper
reason only scores if copper chosen 1
- (good electrical) conductor
accept it is a metal
any mention of heat conduction negates this mark 1
- (ii) lower than 1
- (iii) accept any sensible suggestion, eg:
- too many variables (to control)
 - lightning strikes / storms are random / unpredictable
 - do not know which building will be struck
 - do not know when a building will be struck
 - do not know when lightning will happen
 - (very) difficult to create same conditions in a laboratory
 - lightning storms are not the same
it is not safe is insufficient
do **not** accept lightning does not strike the same place twice 1

[8]

- M2.** (a) ... ammeter
for 1 mark 1
- (b) 5 right
gains 4 marks
- 4 right
gains 3 marks
- 3 right
gains 2 marks
- 2 right
gains 1 mark 4
- [5]**

- M3.** (i) 30
allow 1 mark for showing correct method i.e. 5×6 or $12 \div 0.4$ 2
- (ii) connected in series
insufficient they are not connected in parallel 1
- (iii) 0.4 1
- (iv) equally/ evenly
the same is insufficient
allow credit for candidates that correctly mention pd across the connecting wires
accept (nearly) 2 V (each) 1
- [5]**

M4. The answer to this question requires ideas in good English in a sensible order with correct use of scientific terms. Quality of written communication should be considered in crediting points in the mark scheme.

Maximum of 1 mark if ideas not well expressed

any **two** from:

dust and gas **or** remnants of a super nova

accept hydrogen for dust and gas
do **not** accept hydrogen burns

pulled together by (force of) gravity

nuclear fusion starts

although candidates may include more detail these points are essential to score the credit

[2]

- M5.** (a) (i) Ends have charge
Which is opposite on each rod 2
- (ii) Attracts 1
- (b) (i) Repulsion 1
- (ii) Ends have same charge 1
- (c) Electrons move between cloth and rod
Where gather is negative
Where move from is positive 3

[8]

- M6.** (a) (i) $A_1 = 0.5$
ignore any units 1
- $A_4 = 0.5$
allow 1 mark for $A_1 = A_4 \neq 0.5$ 1
- (ii) the resistance of **P** is more than 20Ω 1
- a smaller current goes through P / A_2 (than 20Ω)
dependent on getting 1st mark correct
accept converse 1

(b) (i) potential difference = current \times resistance

accept pd / voltage for potential difference
accept $V = I \times R$, correct symbols and correct case only
accept volts = amps \times ohms
accept

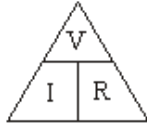

provided subsequent method is correct
allow combination of
physical quantities and named units
allow voltage = $I \times R$

1

(ii) 6

allow 1 mark for correct substitution

2

(iii) 6

accept their (b)(ii)

1

(c) thermistor or

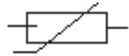

accept correct circuit symbol
allow phonetic spelling

1

resistance goes down (as temperature of thermistor goes up)

*do **not** accept changes for goes down*
*do **not** accept an answer in terms of current only*
answers in terms of other components are incorrect

1

[10]

M7. (a)

Particle	Relative Mass	Relative charge
Proton	1	
Neutron		0

accept one, accept +1
*do **not** accept -1*

1

accept zero
*do **not** accept no charge/ nothing/neutral unless given with 0*

1

(b) equal numbers/amounts of protons and electrons 1

protons and electrons have equal but opposite charge
accept protons charge +1 and electron charge -1
accept (charge) on proton
cancels/balances (charge) on electron
accept positive (charges) cancel out the negative(charges)
neutrons have no charge is neutral
*do **not** accept total charge of protons, electrons (and neutrons) is 0 unless qualified*

(c) (i) (3) fewer neutrons 1

accept lower/ smaller mass number
*do **not** accept different numbers of neutrons*
any mention of fewer/more protons/electrons negates mark
accept answers in terms of U-238 providing U-238 is specifically stated i.e. U-238 has (3) more neutrons

(ii) neutron 1

(iii) (nuclear) fission 1

accept fision
*do **not** accept any spelling that may be taken as fusion*

[7]

M8. (a) J 1

reason only scores if J is chosen

(only) stars (about) the same / smaller size / mass as the Sun become black dwarfs 1

accept smaller than the Sun
accept it is the smallest
accept (only) small stars become black dwarfs

(b) (i) become a supernova 1

or
it will explode
ignore subsequent correct stages

(ii) cannot take measurements needed 1

or
do not have the technology
*do **not** accept cannot measure mass*

(iii) advances in (measuring) techniques / technology / knowledge

1

(c) any **five** from:

ignore any information up to the end of the main sequence

Apply the list rule if more than 5 points are made

- star expands (to become)
- a red giant

red supergiant is incorrect

- heavier elements are formed (by fusion)

elements heavier than iron are formed is incorrect

- star shrinks (to become)
- a white dwarf

supernova, neutron star, black hole are incorrect

- star cools / fades
- star stops emitting energy / radiation

star loses all energy is insufficient

5

[10]

M9. (a) d.c. flows in (only) one direction

1

a.c. changes direction (twice every cycle)

accept a.c. constantly changing direction

ignore references to frequency

1

(b) a current flows through from the live wire / metal case to the earth wire

accept a current flows from live to earth

*do **not** accept on its own if the current is too high*

1

this current causes the fuse to melt

accept blow for melt

*do **not** accept break / snap / blow up for melt*

1

[4]

